



### 4 Gb x 8 , 2 Gb x 16, 1.8 V NAND Flash Memory, LPDDR4x

#### MCP Features

- Multichip package (MCP) consists of:
  - 4Gb SLC NAND and LPDDR4x SDRAM
- LPDDR4x SDRAM on Split Bus
- Low Power Supply Voltage
- Temperature range
  - Industrial:  $-40^{\circ}\text{C}$  to  $+85^{\circ}\text{C}$
  - Industrial Extended:  $-40^{\circ}\text{C}$  to  $+105^{\circ}\text{C}$
  - Automotive:  $-40^{\circ}\text{C}$  to  $+85^{\circ}\text{C}$
  - Automotive Extended:  $-40^{\circ}\text{C}$  to  $+105^{\circ}\text{C}$
- Small MCP Package
  - 8.0 x 9.5 x 0.8 mm, 149-Ball MCP

#### SLC NAND Flash Features

- Density
  - 4Gb NAND Flash Memory
- Page size
  - 4Gb: x8 (4096 + 256) bytes; 256-byte spare area
- Block Size
  - 4Gb: 64 pages : 256 KB + 16 KB
- Number of Planes
  - 4Gb = 1 plane
- Supply Voltage
  - $V_{cc} = 1.7\text{V}$  to  $1.95\text{V}$

#### LPDDR4x SDRAM Features

- Density
  - 2-Gb LPDDR4x SDRAM
- Device Bus Width: x16
- Speed : 1866 MHz
- Organized as 8 banks of 16Mb x 16
- Low-voltage core and I/O power supply
  - $V_{DD1} = 1.8$  (1.70–1.95V);
  - $V_{DD2} = 1.1\text{V}$  (1.06–1.17V);
  - $V_{DDQ} = 0.6\text{V}$  (0.57V - 0.65V)
- Programmable CA ODT and DQ ODT with VSSQ termination
- Single data rate command and address entry
- Bi-directional differential data strobe (DQS\_t, DQS\_c)
- VOH compensated output driver
- Single data rate command and address entry
- Double data rate architecture for data Bus
- Auto refresh and self refresh supported
- All bank auto refresh and directed per bank auto refresh supported
- PASR (Partial Array Self Refresh) by Bank Mask and SegmentMask
- Background ZQ Calibration

### Contents

<b>MCP Features</b> .....	1
LPDDR4x SDRAM Features .....	1
SLC NAND Flash Features .....	1
1. Ordering Information .....	6
2. Product Block Diagram.....	7
3. Connection Diagrams.....	8
4. Input / Output Descriptions .....	9
5. Physical Dimensions.....	10
<b>S34MS02G2: 2Gbit, x8, 1.8V SLC NAND Flash</b> .....	<b>11</b>
Distinctive Characteristics.....	11
1. General Description .....	12
1.4 Block Diagram .....	13
1.5 Array Organization.....	14
1.6 Addressing.....	15
1.7 Mode Selection .....	16
2. Bus Operation .....	17
2.1 Command Input .....	17
2.2 Address Input.....	17
2.3 Data Input .....	17
2.4 Data Output .....	17
2.5 Write Protect .....	17
2.6 Standby .....	17
3. Command Set .....	18
3.1 Page Read .....	19
3.2 Page Program.....	19
3.4 Page Reprogram .....	19
3.5 Block Erase.....	22
3.7 Copy Back Program.....	22
3.8 Read Status Register.....	23
3.9 Read Status Enhanced .....	23
3.10 Read Status Register Field Definition.....	23
3.12 Read Cache .....	25
3.13 Cache Program .....	26
3.15 Read ID .....	28
3.17 Read ONFI Signature.....	30
3.18 Read Parameter Page.....	30
3.19 Read Unique ID (Contact Factory) .....	33
4. Signal Descriptions .....	33
4.1 Data Protection and Power On / Off Sequence .....	33
4.2 Ready/Busy .....	33
4.3 Write Protect Operation .....	34
5. Electrical Characteristics .....	35
5.1 Valid Blocks .....	35
5.3 AC Test Conditions .....	35
5.4 AC Characteristics .....	36
5.5 DC Characteristics .....	37
5.6 Pin Capacitance.....	38
5.7 Program / Erase Characteristics .....	38
6. Timing Diagrams .....	39
6.1 Command Latch Cycle.....	39
6.2 Address Latch Cycle.....	40
6.3 Data Input Cycle Timing.....	40
6.4 Data Output Cycle Timing (CLE=L, WE#=H, ALE=L, WP#=H) .....	41
6.5 Data Output Cycle Timing (EDO Type, CLE=L, WE#=H, ALE=L) .....	41
6.6 Page Read Operation .....	42
6.7 Page Read Operation (Interrupted by CE#) .....	42
6.8 Page Read Operation Timing with CE# Don't Care .....	43
6.9 Page Program Operation.....	43
6.10 Page Program Operation Timing with CE# Don't Care.....	44

6.11	Page Program Operation with Random Data Input .....	44
6.12	Random Data Output In a Page .....	45
6.13	Block Erase Operation .....	45
6.14	Copy Back Read with Optional Data Readout .....	46
6.15	Copy Back Program Operation With Random Data Input .....	46
6.16	Read Status Register Timing .....	46
6.17	Read Status Enhanced Timing .....	47
6.18	Reset Operation Timing .....	47
6.19	Read Cache .....	48
6.20	Cache Program .....	50
6.21	Read ID Operation Timing .....	51
6.22	Read ID2 Operation Timing .....	51
6.23	Read ONFI Signature Timing .....	52
6.24	Read Parameter Page Timing .....	52
6.25	Read Unique ID Timing (Contact Factory) .....	53
6.26	Read ID Operation Timing .....	51
6.27	Power On and Data Protection Timing .....	54
6.28	WP# Handling .....	65
8.	System Interface .....	56
9.	Error Management .....	58
9.1	System Bad Block Replacement .....	58
9.2	Bad Block Management .....	59
<b>2Gbit LPDDR4X SDRAM .....</b>		<b>60</b>
1.	FEATURES .....	60
2.	Functional Description .....	61
2.1.	LPDDR4 SDRAM Addressing .....	61
2.4.	Simplified State Diagram .....	63
2.4.1.	Power-up and Initialization .....	65
2.4.1.1.	Voltage Ramp and Device Initialization .....	65
2.4.1.2.	Reset Initialization with Stable Power .....	67
2.4.2.	Power-off Sequence .....	68
2.4.2.1.	Controlled Power-off .....	68
2.4.2.2.	Uncontrolled Power-off Sequence .....	68
2.5.	Mode Register Definition .....	68
2.5.1	MR0 Register Information (MA[5:0] = 00H) .....	70
2.5.2	MR1 Register Information (MA[5:0] = 01H) .....	70
2.5.2.1	Burst Sequence .....	72
2.5.3	MR2 Register Information (MA[5:0] = 02H) .....	73
2.5.3.1.	Read and Write Latencies (Frequency Ranges for RL, WL, and nWR Settings) .....	74
2.5.4.	MR3 Register Information (MA[5:0] = 03H) .....	74
2.5.5.	MR4 Register Information (MA[5:0] = 04H) .....	75
2.5.6.	MR5 Register Information (MA[5:0] = 05H) .....	76
2.5.7.	MR6 Register Information (MA[5:0] = 06H) .....	77
2.5.8.	MR7 Register Information (MA[5:0] = 07H) .....	77
2.5.9.	MR8 Register Information (MA[5:0] = 08H) .....	77
2.5.10.	MR9 Register Information (MA[5:0] = 09H) .....	78
2.5.11.	MR10 Register Information (MA[5:0] = 0AH) .....	78
2.5.12.	MR11 Register Information (MA[5:0] = 0BH) .....	78
2.5.13.	MR12 Register Information (MA[5:0] = 0CH) .....	79
2.5.14.	MR13 Register Information (MA[5:0] = 0DH) .....	82
2.5.15.	MR14 Register Information (MA[5:0] = 0EH) .....	83
2.5.16.	MR15 Register Information (MA[5:0] = 0FH) .....	85
2.5.17.	MR16 Register Information (MA[5:0] = 10H) .....	85
2.5.18.	MR17 Register Information (MA[5:0] = 11H) .....	86
2.5.19.	MR18 Register Information (MA[5:0] = 12H) .....	86
2.5.20.	MR19 Register Information (MA[5:0] = 13H) .....	87
2.5.21.	MR20 Register Information (MA[5:0] = 14H) .....	87
2.5.22.	MR21 Register Information (MA[5:0] = 15H) .....	88
2.5.23.	MR22 Register Information (MA[5:0] = 16H) .....	88
2.5.24.	MR23 Register Information (MA[5:0] = 17H) .....	89
2.5.25.	MR24 Register Information (MA[5:0] = 18H) .....	90
2.5.26.	MR25 Register Information (MA[5:0] = 19H) .....	91

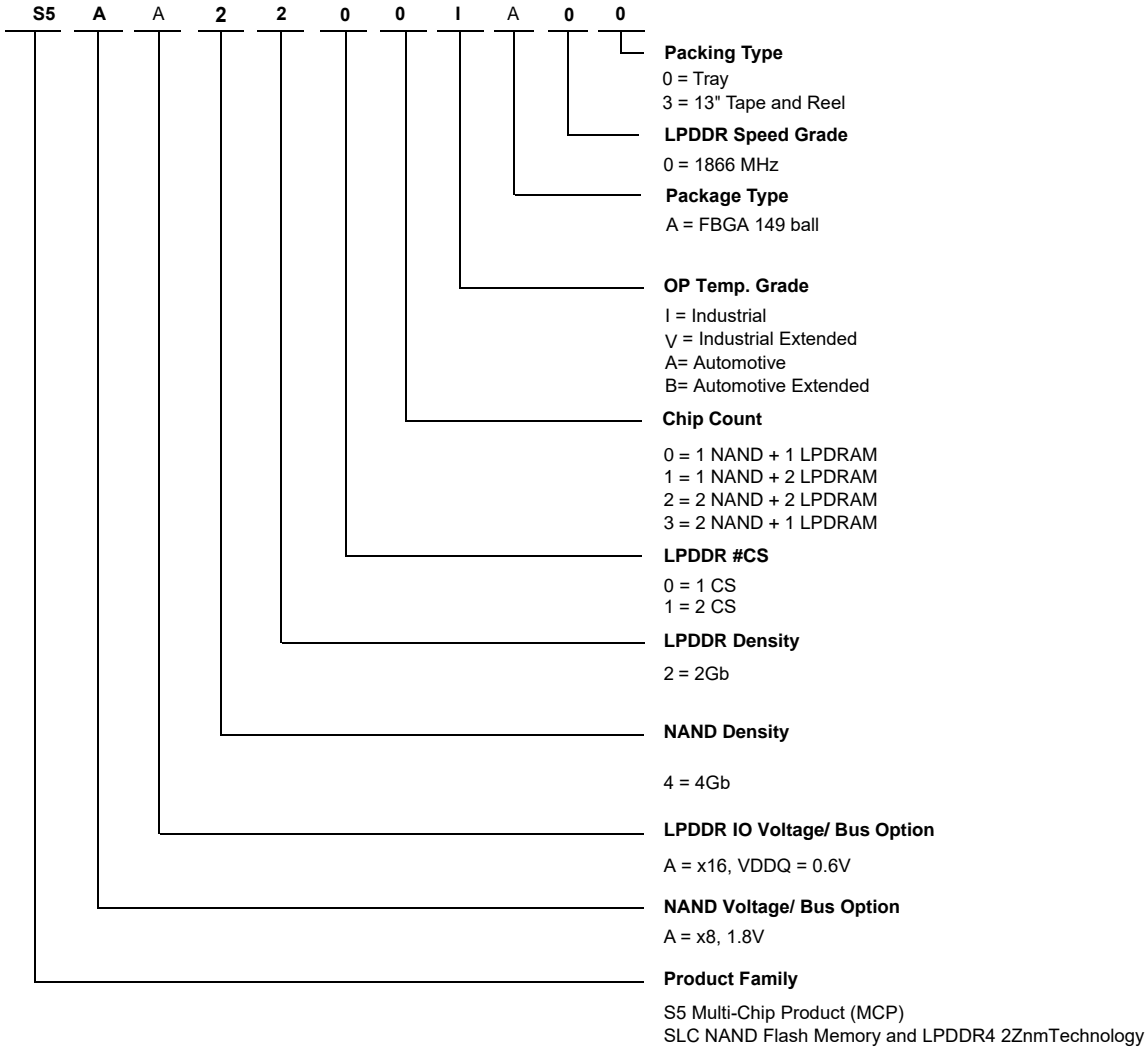
2.5.27.	MR26:31 Register Information (MA[5:0] = 1AH:1FH) .....	91
2.5.28.	MR32 Register Information (MA[5:0] = 20H) .....	92
2.5.29.	MR33:36 Register Information (MA[5:0] = 21H:24H) .....	92
2.5.30.	MR37 Register Information (MA[5:0] = 25H) Optional .....	92
2.5.31.	MR38:39 Register Information (MA[5:0] = 26H:27H) .....	92
2.5.32.	MR40 Register Information (MA[5:0] = 28H) .....	93
3.	LPDDR4 Command Definitions and Timing Diagrams .....	94
3.1.	Activate Command .....	94
3.3.1	Bank Device Operation .....	94
3.2.	Read and Write Access Operations .....	95
3.3.	Read Preamble and Postamble .....	95
3.4.	Burst Read Operation .....	96
3.5.	Read Timing .....	99
3.6.	tLZ(DQS), tLZ(DQ), tHZ(DQS), tHZ(DQ) Calculation .....	99
3.6.1.	tLZ(DQS) and tHZ(DQS) Calculation for ATE (Automatic Test Equipment) .....	99
3.6.2.	tLZ(DQ) and tHZ(DQ) Calculation for ATE (Automatic Test Equipment) .....	102
3.7.	Write Preamble and Postamble .....	103
3.8.	Burst Write Operation .....	105
3.9.	Write Timing .....	107
3.9.1.	tWPRE Calculation for ATE (Automated Test Equipment) .....	109
3.9.2.	tWPST Calculation for ATE (Automatic Test Equipment) .....	110
3.10.	Postamble and Preamble merging behavior .....	110
3.10.1.	Read to Read Operation .....	110
3.11.	Masked Write Operation .....	123
3.11.1.	Masked Write Timing constraints .....	125
3.12.	LPDDR4 Data Mask (DM) and Data Bus Inversion (DBI <sub>dc</sub> ) Function .....	126
3.13.	Precharge Operation .....	128
3.13.1.	Burst Read Operation followed by Precharge .....	130
3.13.2.	Burst Write followed by Precharge .....	131
3.13.3.	Auto Precharge operation .....	131
3.13.3.1.	Burst Read with Auto-Precharge .....	133
3.13.3.2.	Burst Write with Auto-Precharge .....	135
3.13.3.3.	Delay Time from Write to Read with Auto Precharge .....	137
3.14.	Refresh command .....	137
3.15.	LPDDR4 Refresh Requirements by Device Density .....	143
3.16.	Self Refresh Operation .....	144
3.16.1.	Self Refresh Entry and Exit .....	144
3.16.2.	Power Down Entry and Exit during Self Refresh .....	145
3.16.3.	Command Input Timing after Power Down Exit .....	147
3.16.4.	Self Refresh Abort .....	147
3.17.	MRR, MRW, MPC Command during tXSR, tRFC .....	148
3.18.	Mode Register Read (MRR) command .....	148
3.18.1.	MRR after Read and Write command .....	150
3.18.2.	MRR after Power-Down Exit .....	152
3.19.	Mode Register Write (MRW) command .....	152
3.19.1.	Mode Register Write .....	153
3.20.	Vref Current Generator (VRCG) .....	155
3.21.	CA Vref Training .....	156
3.22.	DQ Vref Training .....	162
3.23.	Command Bus Training .....	167
3.23.0.1.	Training Sequence for single-rank systems: .....	169
3.23.0.2.	Training Sequence for multi-rank systems: .....	169
3.23.0.3.	Relation between CA input pin and DQ output pin .....	170
3.23.0.4.	Timing Diagram .....	171
3.24.	Frequency Set Point (FSP) .....	174
3.24.0.1.	Frequency Set Point update timing .....	176
3.25.	Write Leveling Mode .....	179
3.25.1	Input Clock Frequency Stop and Change .....	182
3.26.	MPC [RD DQ Calibration] Command .....	182
3.26.1.	MPC [RD DQ Calibration] Example .....	185
3.26.2.	MPC of Read DQ Calibration after Power-Down Exit .....	186
3.27.	MPC Write Training (DQS-DQ Training) .....	186
3.27.1.	FIFO Pointer Reset and Synchronism .....	187



3.28.	DQS Interval Oscillator .....	192
3.28.1.	Interval Oscillator matching error .....	194
3.28.2.	DQS Interval Oscillator Readout Timing .....	196
3.29.	Read Preamble Training .....	196
3.30.	Multi Purpose Command (MPC) .....	197
3.31.	Thermal offset .....	201
3.32.	Temperature Sensor .....	202
3.33.	ZQ Calibration .....	203
3.33.1.	ZQCal Reset .....	204
3.33.2.	Multi-Channel Considerations .....	204
3.33.2.1.	ZQ External Resistor, Tolerance, and Capacitive Loading .....	205
3.33.2.2.	ZQ Wiring for Byte-mode PKG including mixed configuration .....	205
3.35.	Command/Address Bus On Die Termination .....	207
3.35.1.	ODT Mode Register and ODT State Table .....	207
3.35.2.	ODT Mode Register and ODT characteristics .....	208
3.35.3.	ODT for Command/Address update time .....	209
3.36.	DQ On-die Termination .....	209
3.36.1.	ODT Mode Register .....	210
3.36.2.	Asynchronous ODT .....	210
3.36.3.	ODT during Write Leveling .....	213
3.37.	On Die Termination for DQ, DQS and DMI .....	213
3.38.	Output Driver and Termination Register Temperature and Voltage Sensitivity .....	214
3.39.	Power Down Mode .....	215
3.39.1.	Power Down Entry and Exit .....	215
3.40.	Input clock stop and frequency change .....	222
3.41.	Truth Tables .....	222
3.41.1.	Command Truth Table .....	223
3.42.	Post Package Repair - PPR .....	224
3.42.1.	Fail Row Address Repair .....	224
4.	Absolute Maximum DC Ratings .....	226
5.	AC and DC Operating Conditions .....	227
5.1	Recommended DC Operating Conditions .....	227
5.2	Input Leakage Current .....	227
5.3.	Input/Output Leakage Current .....	227
5.4.	Operating Temperature .....	227
6.	AC and DC Input Measurement Levels .....	228
6.1	1.1V High speed LVCMOS (HS_LLVC MOS) .....	228
6.1.1.	Standard specifications .....	228
6.1.2.	LPDDR4 Input Level for Reset_n and ODT_CA .....	228
6.1.3.	AC Over/Undershoot .....	229
6.1.3.1.	LPDDR4 AC Over/Undershoot .....	229
6.2.	Differential Input Voltage .....	229
6.2.1.	Differential Input Voltage for CK .....	229
6.2.2.	Differential Input Voltage for DQS .....	231
6.3.	Differential Input Cross Point Voltage .....	231
6.4.	AC and DC Logic Input Levels for ODT input .....	233
6.5.	Single Ended Output Slew Rate .....	233
6.6.	Differential Output Slew Rate .....	234
6.7.	Overshoot and Undershoot Specification for LVSTL .....	235
6.8.	LVSTL Driver Output Timing Reference Load .....	235
6.9.	LVSTL (Low Voltage Swing Terminated Logic) IO System .....	236
7.	Input/Output Capacitance .....	238
8.	IDD Specification Parameters and Test Conditions .....	239
8.1.	IDD Measurement Conditions .....	240
8.2.	IDD Specifications .....	244
9.	Electrical Characteristics and AC Timings .....	247
9.1	AC Timing Parameters .....	247
9.2.	CA Rx voltage and timing .....	255
9.3.	DRAM Data Timing .....	257
9.4.	DQ Rx Voltage and Timing Definition .....	258
10.	Revision History .....	262
10.1	Document History Page .....	262

### 1. Ordering Information

The order number (Valid Combination) is formed by the following:



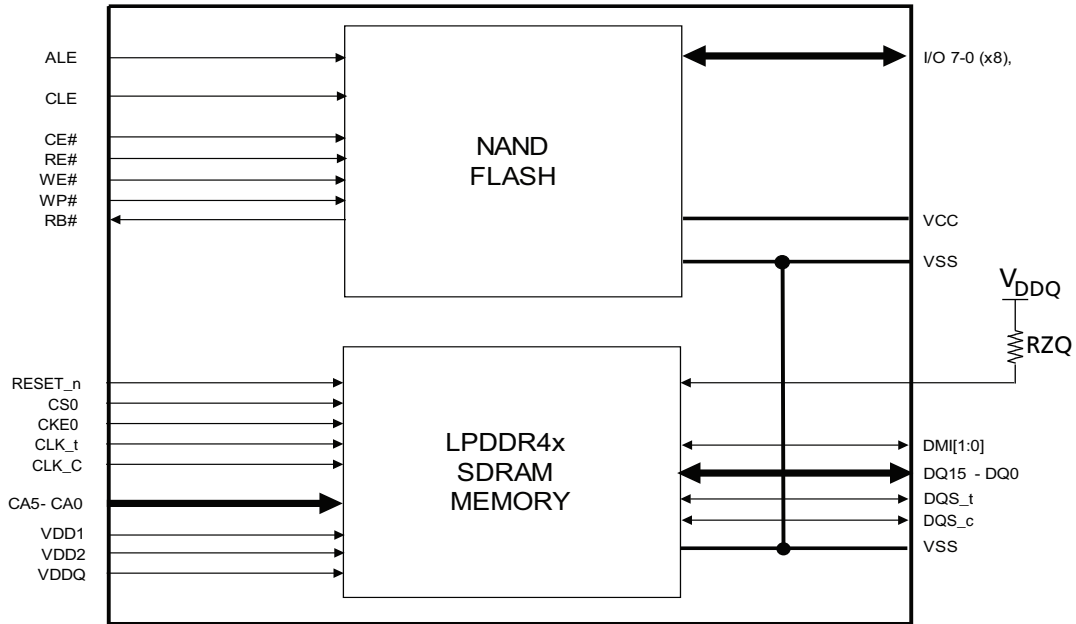
#### 1.1 Valid Combinations

Valid Combinations list configurations planned to be supported in volume for this device. Consult your local sales office to confirm availability of specific valid combinations and to check on newly released combinations.

Device Family	NAND Voltage/ Bus	LPDDR Voltage/ Bus	NAND Density	LPDDR Density	LPDDR #CS	Chip Count	Temp. Grade	Package Type	LPDDR Speed Grade	Packing Type	Package
S5	A	A	4	2	0	0	I,V	A	0	0	149-ball FBGA

### 2. Product Block Diagram

Figure 2.1 Block Diagram



### 3. Connection Diagrams

Figure 3.1 149-Ball Ball Grid Array MCP

	1	2	3	4	5	6	7	8	9	10	11	12	13	14
A	DNU	DNU											DNU	DNU
B	DNU	NC	NC	NC	NC	NC	NC			NC	NC	VCC	NC	DNU
C	NC	NC	NC	WP#	R/B#	Vss	WE#			Vss	IO7	IO6	VCC	NC
D	NC	NC	NC	NC	CE#	Vss	RE#			ALE	Vss	Vss	IO1	IO4
E					VDD2	VDD2	VDD2			Vss	IO2	IO5	Vcc	Vcc
F	DQ10	VDD2	DQ8	DQ9	Vss	Vss	DQS1_t			CLE	Vss	Vss	IO3	IO0
G	DQ11	VDDQ	VDDQ	Vss	DQ12	VDDQ	DQS1_c				NC	NC	NC	NC
H	DMI1	Vss	VDDQ	DQ14	Vss	DQ15	VDDQ				Vss	NC	Vss	CLK_t
J	DQ13	Vss	Vss	Vss	VDD2	VDD2	VDD2				Vss	CA0	Vss	CLK_c
K											CA1	Vss	RFU	RFU
L											CA4	Vss	CS0	CKE0
M	DQ3	Vss	DMI0	Vss	DQ6	Vss	DQS0_c				CA3	Vss	Vss	RESET_n
N	DQ2	Vss	Vss	DQ5	Vss	DQ7	DQS0_t				CA2	Vss	CA5	RFU
P	DQ1	DQ0	VDDQ	Vss	DQ4	Vss	VDD2				VDD2	VDD2	VDD1	ZQ0
R	DNU	VDD1	VDD2	VDDQ	VDDQ	VDD2	VDD1				VDDQ	VDDQ	VDD1	DNU
T	DNU	DNU											DNU	DNU

TOP VIEW ( ball down )



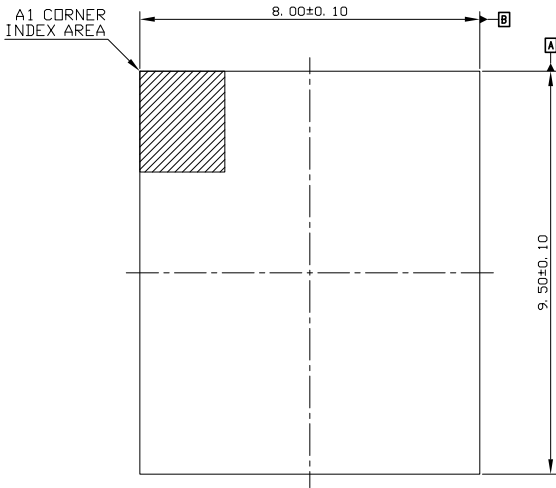
### 4. Input / Output Descriptions

Figure 4.1 Input / Output Descriptions

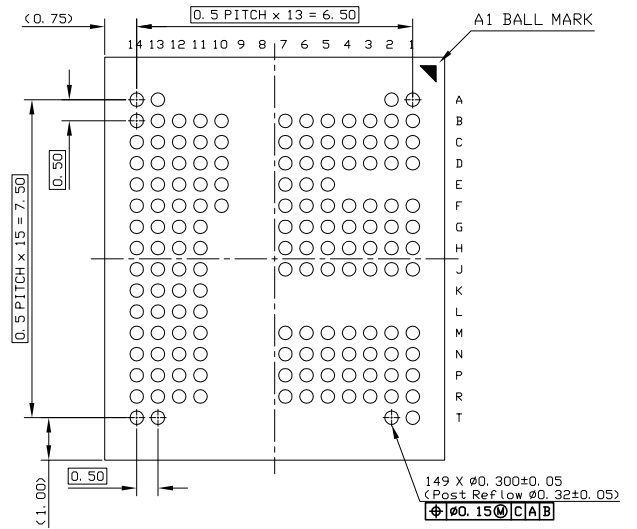
Symbol	Description	NAND	DRAM
IO7 – IO0	Flash Multiplexed Address and Data	X	
CE#	Flash Chip-enable Input.	X	
RE#	Read Enable	X	
RB#	Ready Busy	X	
WE#	Flash Write Enable Input	X	
WP#	Write Protect	X	
CLE	Command Latch Enable	X	
ALE	Address Latch Enable	X	
VCC	Flash Power Supply	X	
DQ15 – DQ0	SDRAM Data Input/Output		X
CLK_t, CLK_c	Differential Clock inputs		X
CEK0	Clock Enable		X
CS0	Chip Enable		X
CA5 – CA0	Command/Address Input		X
DQS0_t – DQS0_c	Bi-directional Differential Output Clock signals		X
DQS1_t – DQS1_c	Bi-directional Differential Output Clock Signals		X
DMI0, DMI1	Data Mask/ Data Bus Inversion		X
ZQ	Calibration Reference		X
Reset_n	Reset		X
VDD1, VDD2, VDDQ	Power Supplies - Isolated		X
VSS	Ground	X	X
NC	No Connect		
DNU	Do not Use		
RFU	Reserved for Future Use		

### 5. Physical Dimensions

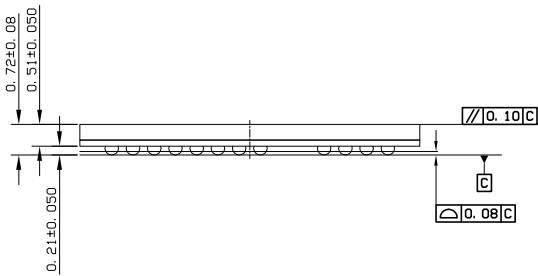
#### 5.1 149 Ball (FBGA)8.0 x 9.5 x 0.8 mm



TOP VIEW



BOTTOM VIEW



SIDE VIEW

Notes: 1. All dimensions are in millimeters.

### S34MS04G2: 4Gbit, x8, 1.8V SLC NAND Flash

#### Distinctive Characteristics

- Density
  - 4 Gb
- Architecture
  - Input / Output Bus Width: 8 bits
  - Page size:
    - 4 Gb: (4096 + 256) bytes; 256-byte spare area
  - Block size: 64 Pages
    - 256 KB + 16 KB
  - Plane size:
    - 2048 Blocks (256 MB + 16 MB)
  - Device size:
    - 1 plane per device or 512 MB
- NAND flash interface
  - Open NAND Flash Interface (ONFI) 1.0 compliant
  - Address, Data, and Commands multiplexed
- Supply voltage
  - 1.8 V device:  $V_{CC} = 1.7 V \sim 1.95 V$
- Security
  - One Time Programmable (OTP) area
  - Serial number (unique ID) (Contact factory for support)
  - Hardware program/erase disabled during power transition
- Electronic signature
  - Manufacturer ID: 01h
- Operating temperature
  - Industrial:  $-40\text{ }^{\circ}\text{C}$  to  $85\text{ }^{\circ}\text{C}$
  - Industrial Plus:  $-40\text{ }^{\circ}\text{C}$  to  $105\text{ }^{\circ}\text{C}$
- Reliability
  - 100,000 Program / Erase cycles (Typ)  
(with 4-bit ECC per 544 bytes (x8))
  - 10-year Data retention (Typ)
  - Block zero is valid and will be valid for at least 1,000 program-erase cycles with ECC
- Package options
  - Pb-free and Low Halogen
  - 48-Pin TSOP  $12 \times 20 \times 1.2\text{ mm}$
  - 63-Ball BGA  $9 \times 11 \times 1\text{ mm}$

#### Performance

- Page Read / Program
  - Random access: 30  $\mu\text{s}$  (Max)
  - Sequential access: 45 ns (Min)
  - Program time: 300  $\mu\text{s}$  (Typ)
- Block Erase
  - Block Erase time: 3.5 ms (Typ)



## 1. General Description

The SkyHigh S34MS04G2 series is offered in 1.8 V<sub>CC</sub> and V<sub>CCQ</sub> power supply, and with x8 I/O interface. Its NAND cell provides the most cost-effective solution for the solid state mass storage market. The memory is divided into blocks that can be erased independently so it is possible to preserve valid data while old data is erased. The page size for x8 is (4096 + spare) bytes.

Each block can be programmed and erased up to 100,000 cycles with ECC (error correction code) on. To extend the lifetime of NAND flash devices, the implementation of an ECC is mandatory.

The chip supports CE# don't care function. This function allows the direct download of the code from the NAND flash memory device by a microcontroller, since the CE# transitions do not stop the read operation.

The devices have a Read Cache feature that improves the read throughput for large files. During cache reading, the devices load the data in a cache register while the previous data is transferred to the I/O buffers to be read.

Like all other 4-KB page NAND flash devices, a program operation typically writes 4 KB (x8) in 300 μs and an erase operation can typically be performed in 3.5 ms.

In the Read operations, data in the page can be read out at 45 ns cycle time per byte. The I/O pins serve as the ports for command and address input as well as data input/output. This interface allows a reduced pin count and easy migration towards different densities, without any rearrangement of the footprint.

Commands, Data, and Addresses are asynchronously introduced using CE#, WE#, ALE, and CLE control pins.

The on-chip Program/Erase Controller automates all read, program, and erase functions including pulse repetition, where required, and internal verification and margining of data. A WP# pin is available to provide hardware protection against program and erase operations.

The output pin R/B# (open drain buffer) signals the status of the device during each operation. It identifies if the program/erase/read controller is currently active. The use of an open-drain output allows the Ready/Busy pins from several memories to connect to a single pull-up resistor. In a system with multiple memories the R/B# pins can be connected all together to provide a global status signal.

The Reprogram function allows the optimization of defective block management — when a Page Program operation fails the data can be directly programmed in another page inside the same array section without the time consuming serial data insertion phase.

The devices provide an innovative feature: Page Reprogram. The Page Reprogram re-programs one page. Normally, this operation is performed after a failed Page Program operation.

The devices come with the following security features:

- OTP (one time programmable) area, which is a restricted access area where sensitive data/code can be stored permanently.
- Serial number (unique identifier), which allows the devices to be uniquely identified. Contact factory for support of this feature.

These security features are subject to an NDA (non-disclosure agreement) and are, therefore, not described in the data sheet. For more details about them, contact your nearest SkyHigh sales office.

Device	Density (bits)		Number of Planes	Number of Blocks per Plane
	Main	Spare		
S34MS04G2	512M x 8	32M x 8	1	2048

## 1.1 Logic Diagram

Figure 1.1 Logic Diagram

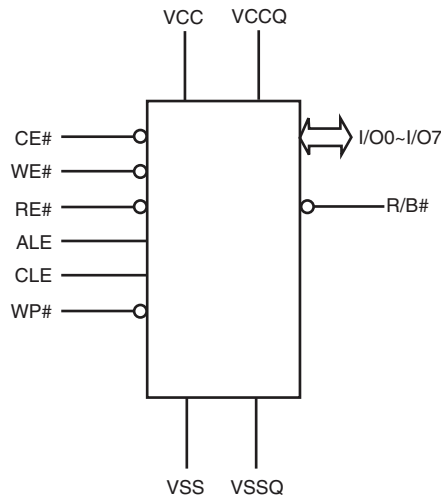
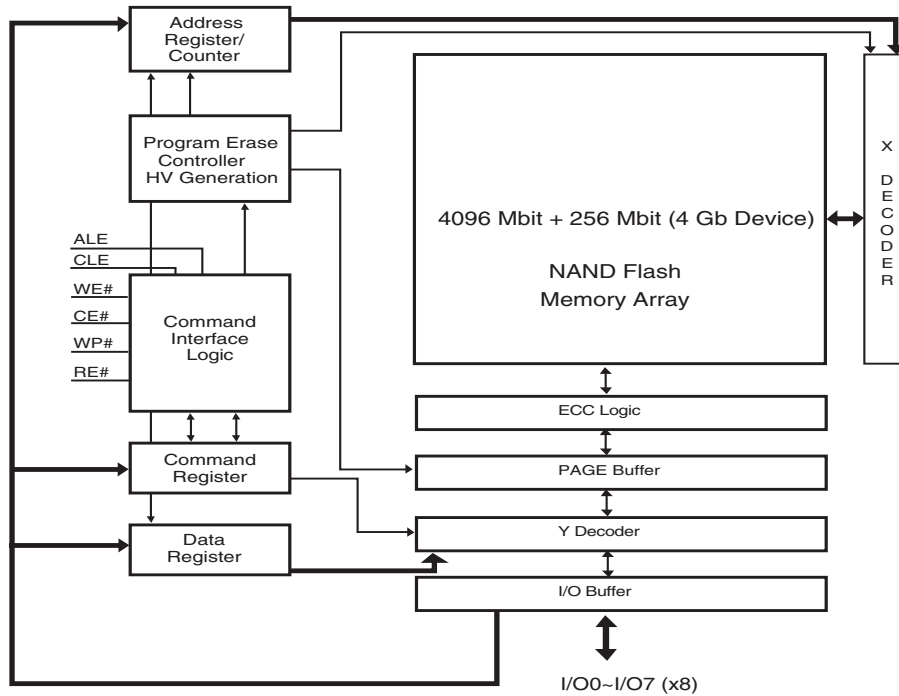


Table 1.1 Signal Names

I/O7 - I/O0 (x8)	Data Input / Outputs
CLE	Command Latch Enable
ALE	Address Latch Enable
CE#	Chip Enable
RE#	Read Enable
WE#	Write Enable
WP#	Write Protect
R/B#	Read/Busy
VCC	Power Supply
VSS	Ground
NC	Not Connected

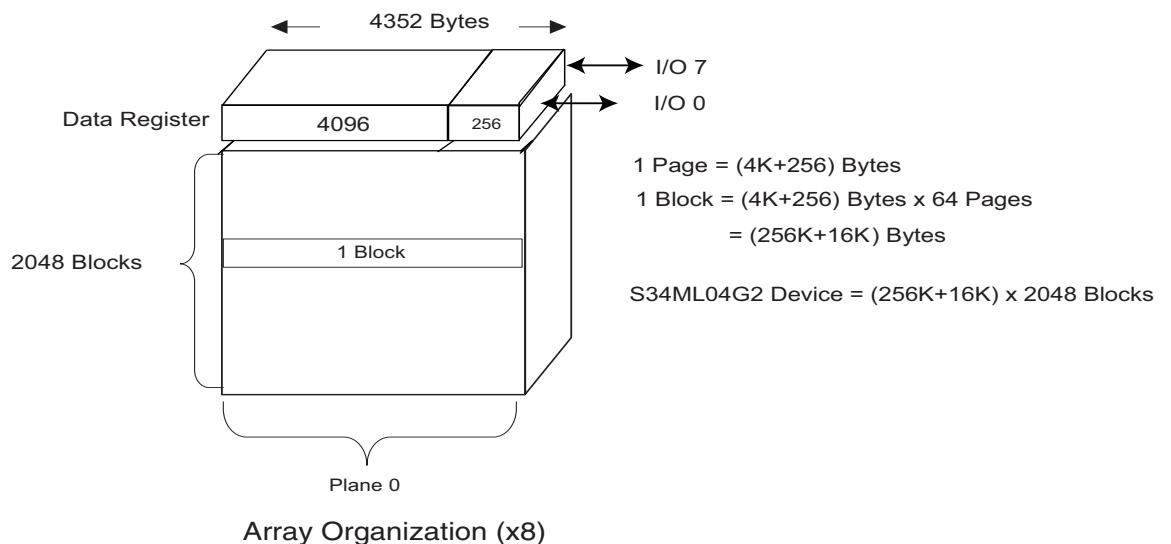
### 1.3 Block Diagram

Figure 1.6 Functional Block Diagram



### 1.4 Array Organization

Figure 1.7 Array Organization



## 1.5 Addressing

### 1.6.1 Memory Address Phase Cycles

Table 4 provides the memory organization and the address bit requirements for each devices supported.

**Table 4. Memory Array Organization and Address Bit Requirements**

Density Page Size	Device and Array Organization											Address bits
	Page Size	LUN	Planes	#block per Plane	Page per Block	Spare Byte per Page	Spare Byte per NOP	NOP	Partial Word Size	CA Bits	PA Bits	BA Bits
04Gb	4KB	1	1	2048	64	256	64	4	1024B	13	6	11

**Legend:**

CA = Column address bit.

PA = Page Address bit.

BA = Block Address bit.

Table 5 provides the address phase cycles for the X8 mode of operation.

**Table 5. Address Phase Cycles for X8 Mode of Operation**

Bus Cycle	Name	IO[7]	IO[6]	IO[5]	IO[4]	IO[3]	IO[2]	IO[1]	IO[0]
1st	Col Add 1 (C1)	CA[7]	CA[6]	CA[5]	CA[4]	CA[3]	CA[2]	CA[1]	CA[0]
2nd	Col Add 2 (C2)	L	L	L	CA[12]	CA[11]	CA[10]	CA[9]	CA[8]
3rd	Row Add 1 (R1)	BA[1]	BA[0]	PA[5]	PA[4]	PA[3]	PA[2]	PA[1]	PA[0]
4th	Row Add 2 (R2)	BA[9]	BA[8]	BA[7]	BA[6]	BA[5]	BA[4]	BA[3]	BA[2]
5th	Row Add 3 (R3)	L	L	L	L	L	L	L	BA[10]

**Note**

4. Block address concatenated with page address = actual page address, also known as the row address.

**Legend:**

CAx = Column Address bit.

Pax = Page Address bit.

Bax = Block Address bit.

Density_Page Size	x8 Bus Width	Additional Notes
	CA[12:0]	
04Gb_4KB	CA[12:0]	If CA[12] = 1, then CA[10:7] must be low

**Note**

5. Block address BA[10:0].

Density_Page Size	#of LUNs	# of Planes	#Blocks per Plane	BA	Additional Notes
04Gb_4KB	1	1	2048	BA[10:0]	

### 1.6 Mode Selection

**Table 1.6 Mode Selection**

Mode		CLE	ALE	CE#	WE#	RE#	WP#
Read Mode	Command Input	High	Low	Low	Rising	High	X
	Address Input	Low	High	Low	Rising	High	X
Program or Erase Mode	Command Input	High	Low	Low	Rising	High	High
	Address Input	Low	High	Low	Rising	High	High
Data Input		Low	Low	Low	Rising	High	High
Data Output (on going)		Low	Low	Low	High	Falling	X
Data Output (suspended)		X	X	X	High	High	X
Busy Time in Read		X	X	X	High	High (3)	X
Busy Time in Program		X	X	X	X	X	High
Busy Time in Erase		X	X	X	X	X	High
Write Protect		X	X	X	X	X	Low
Stand By		X	X	High	X	X	0V / V <sub>CC</sub> (2)

**Notes:**

1. X can be V<sub>IL</sub> or V<sub>IH</sub>. High = Logic level high. Low = Logic level low.
2. WP# should be biased to CMOS high or CMOS low for stand-by mode.
3. During Busy Time in Read, RE# must be held high to prevent unintended data out.

## 2. Bus Operation

There are six standard bus operations that control the device: Command Input, Address Input, Data Input, Data Output, Write Protect, and Standby. (See [Table 1.6.](#))

Typically glitches less than 5 ns on Chip Enable, Write Enable, and Read Enable are ignored by the memory and do not affect bus operations.

### 2.1 Command Input

The Command Input bus operation is used to give a command to the memory device. Commands are accepted with Chip Enable low, Command Latch Enable high, Address Latch Enable low, and Read Enable high and latched on the rising edge of Write Enable. Moreover, for commands that start a modify operation (program/erase) the Write Protect pin must be high. See [Figure 6.1](#) and [Table 5.4](#) for details of the timing requirements. Command codes are always applied on I/O7:0.

### 2.2 Address Input

The Address Input bus operation allows the insertion of the memory address. For S34MS04G2 devices, five write cycles are needed to input the addresses. Addresses are accepted with Chip Enable low, Address Latch Enable high, Command Latch Enable low, and Read Enable high and latched on the rising edge of Write Enable. Moreover, for commands that start a modify operation (program/erase) the Write Protect pin must be high. See [Figure 6.2](#) and [Table 5.4](#) for details of the timing requirements.

### 2.3 Data Input

The Data Input bus operation allows the data to be programmed to be sent to the device. The data insertion is serial and timed by the Write Enable cycles. Data is accepted only with Chip Enable low, Address Latch Enable low, Command Latch Enable low, Read Enable high, and Write Protect high and latched on the rising edge of Write Enable. See [Figure 6.3](#) and [Table 5.4](#) for details of the timings requirements

### 2.4 Data Output

The Data Output bus operation allows data to be read from the memory array and to check the Status Register content, and the ID data. Data can be serially shifted out by toggling the Read Enable pin with Chip Enable low, Write Enable high, Address Latch Enable low, and Command Latch Enable low. See [Figure 6.4](#) and [Table 5.4](#) for details of the timings requirements.

### 2.5 Write Protect

The Hardware Write Protection is activated when the Write Protect pin is low. In this condition, modify operations do not start and the content of the memory is not altered. The Write Protect pin is not latched by Write Enable to ensure the protection even during power up.

### 2.6 Standby

In Standby, the device is deselected, outputs are disabled, and power consumption is reduced.

### 3. Command Set

Table 3.1 Command Set

Command	1st Cycle	2nd Cycle	3rd Cycle	4th Cycle	Acceptable Command during Busy	
Page Read	00h	30h			No	
Page Program	80h	10h			No	
Random Data Input	85h				No	
Random Data Output	05h	E0h			No	
Page Reprogram	8Bh	10h			No	
Block Erase	60h	D0h			No	
Copy Back Read	00h	35h			No	
Copy Back Program	85h	10h			No	
Special Read For Copy Back	00h	36h			No	
Read Status Register	70h				Yes	
Read Status Enhanced	78h				Yes	
Reset	FFh				Yes	
Read Cache	31h				No	
Read Cache Enhanced	00h	31h			No	
Read Cache End	3Fh				No	
Cache Program (End)	80h	10h			No	
Cache Program (Start) / (Continue)	80h	15h			No	
Read ID	90h				No	
Read ID2	30h-65h-00h	30h			No	
Read ONFI Signature	90h				No	
Read Parameter Page	ECh				No	
Read Unique ID (Contact Factory)	EDh				No	
One-time Programmable (OTP) Area Entry	29h-17h-04h-19h				No	



### 3.1 Page Read

Page Read is initiated by writing 00h and 30h to the command register along with five address cycles. Two types of operations are available: random read and serial page read. Random read mode is enabled when the page address is changed. All data within the selected page are transferred to the data registers. The system controller may detect the completion of this data transfer ( $t_R$ ) by analyzing the output of the R/B pin. Once the data in a page is loaded into the data registers, they may be read out in 45 ns cycle time by sequentially pulsing RE#. The repetitive high to low transitions of the RE# signal makes the device output the data, starting from the selected column address up to the last column address.

The device may output random data in a page instead of the sequential data by writing Random Data Output command. The column address of next data, which is going to be out, may be changed to the address that follows Random Data Output command. Random Data Output can be performed as many times as needed.

After power up, the device is in read mode, so 00h command cycle is not necessary to start a read operation. Any operation other than read or Random Data Output causes the device to exit read mode.

See [Figure 6.6](#) and [Figure 6.12](#) as references.

### 3.2 Page Program

A page program cycle consists of a serial data loading period in which up to 4 KB (x8) of data may be loaded into the data register, followed by a non-volatile programming period where the loaded data is programmed into the appropriate cell.

The serial data loading period begins by inputting the Serial Data Input command (80h), followed by the five cycle address inputs and then serial data. The words other than those to be programmed do not need to be loaded. The device supports Random Data Input within a page. The column address of next data, which will be entered, may be changed to the address that follows the Random Data Input command (85h). Random Data Input may be performed as many times as needed.

The Page Program confirm command (10h) initiates the programming process. The internal write state controller automatically executes the algorithms and controls timings necessary for program and verify, thereby freeing the system controller for other tasks.

Once the program process starts, the Read Status Register commands (70h or 78h) may be issued to read the Status Register. The system controller can detect the completion of a program cycle by monitoring the R/B# output, or the Status bit (I/O6) of the Status Register. Only the Read Status commands (70h or 78h) or Reset command are valid while programming is in progress. When the Page Program is complete, the Write Status Bit (I/O0) may be checked. The internal write verify detects only errors for 1's that are not successfully programmed to 0's. The command register remains in Read Status command mode until another valid command is written to the command register. [Figure 6.9](#) and [Figure 6.11](#) detail the sequence.

The device is programmable by page, but it also allows multiple partial page programming of a word or consecutive bytes up to the full page in a single page program cycle.

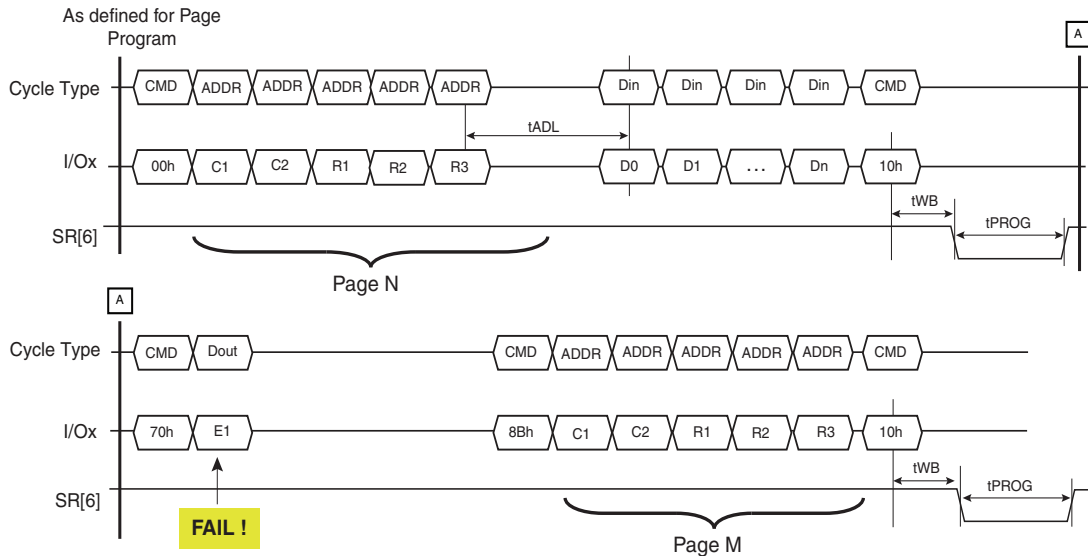
The number of consecutive partial page programming operations (NOP) within the same page must not exceed the number indicated in [Table 5.7](#). Pages may be programmed in any order within a block.

If a Page Program operation is interrupted by hardware reset, power failure or other means, the host must ensure that the interrupted page is not used for further reading or programming operations until the next uninterrupted block erase is complete.

### 3.4 Page Reprogram

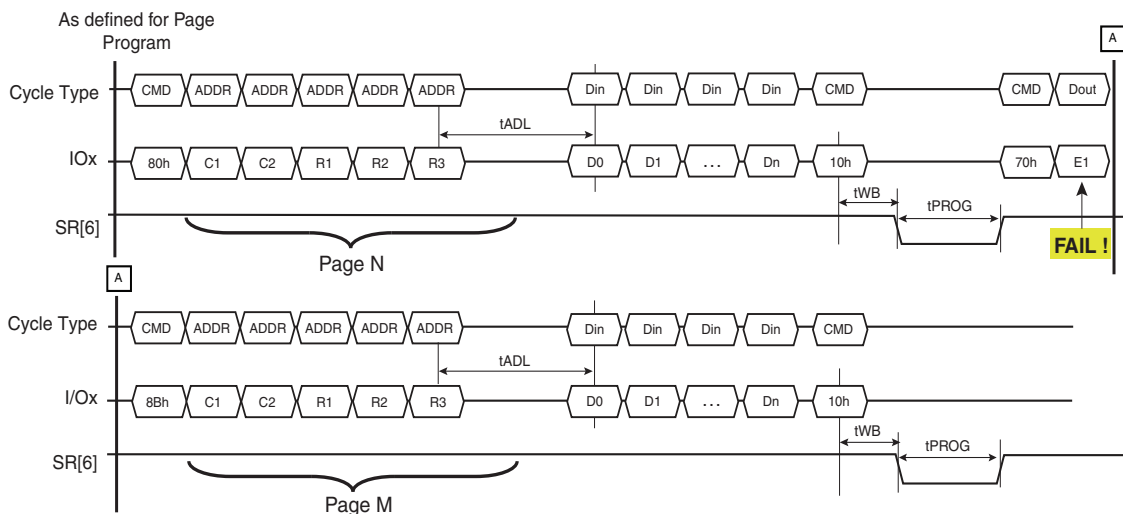
Page Program may result in a fail, which can be detected by Read Status Register. In this event, the host may call Page Reprogram. This command allows the reprogramming of the same pattern of the last (failed) page into another memory location. The command sequence initiates with reprogram setup (8Bh), followed by the five cycle address inputs of the target page. If the target pattern for the destination page is not changed compared to the last page, the program confirm can be issued (10h) without any data input cycle, as described in [Figure 3.1](#).

**Figure 3.1 Page Reprogram**



On the other hand, if the pattern bound for the target page is different from that of the previous page, data in cycles can be issued before program confirm '10h', as described in Figure 3.2.

**Figure 3.2 Page Reprogram with Data Manipulation**



The device supports Random Data Input within a page. The column address of next data, which will be entered, may be changed to the address which follows the Random Data Input command (85h). Random Data Input may be operated multiple times regardless of how many times it is done in a page.

The Program Confirm command (10h) initiates the re-programming process. The internal write state controller automatically executes the algorithms and controls timings necessary for program and verify, thereby freeing the system controller for other tasks. Once the program process starts, the Read Status Register command may be issued to read the Status Register. The system controller can detect the completion of a program cycle by monitoring the R/B# output, or the Status bit (I/O6) of the Status Register. Only the Read Status command and Reset command are valid when programming is in progress. When the Page Program is complete, the Write Status Bit (I/O0) may be checked. The internal write verify detects only errors for 1's that are not successfully programmed to 0's. The command register remains in Read Status command mode until another valid command is written to the command register.

The Page Reprogram must be issued in the same plane as the Page Program that failed. In order to program the data to a different plane, use the Page Program operation instead.

If a Page Reprogram operation is interrupted by hardware reset, power failure or other means, the host must ensure that the interrupted page is not used for further reading or programming operations until the next uninterrupted block erase is complete.

### 3.5 Block Erase

The Block Erase operation is done on a block basis. Block address loading is accomplished in three cycles initiated by an Erase Setup command (60h). Only the block address bits are valid while the page address bits are ignored.

The Erase Confirm command (D0h) following the block address loading initiates the internal erasing process. This two-step sequence of setup followed by the execution command ensures that memory contents are not accidentally erased due to external noise conditions.

At the rising edge of WE# after the erase confirm command input, the internal write controller handles erase and erase verify. Once the erase process starts, the Read Status Register commands (70h or 78h) may be issued to read the Status Register.

The system controller can detect the completion of an erase by monitoring the R/B# output, or the Status bit (I/O6) of the Status Register. Only the Read Status commands (70h or 78h) and Reset command are valid while erasing is in progress. When the erase operation is completed, the Write Status Bit (I/O0) may be checked. [Figure 6.13](#) details this sequence.

If a Block Erase operation is interrupted by hardware reset, power failure or other means, the host must ensure that the interrupted block is erased under continuous power conditions before that block can be trusted for further programming and reading operations.

## 3.6 Copy Back Program

The copy back feature is intended to quickly and efficiently rewrite data stored in one page without utilizing an external memory. Since the time-consuming cycles of serial access and re-loading cycles are removed, the system performance is greatly improved. The benefit is especially obvious when a portion of a block needs to be updated and the rest of the block also needs to be copied to the newly assigned free block. The operation for performing a copy back is a sequential execution of page-read (without mandatory serial access) and Copy Back Program with the address of destination page. A read operation with the '35h' command and the address of the source page moves the whole page of data into the internal data register. As soon as the device returns to the Ready state, optional data read-out is allowed by toggling RE# (see [Figure 6.14](#)), or the Copy Back Program command (85h) with the address cycles of the destination page may be written. The Program Confirm command (10h) is required to actually begin programming.

Copy Back Read and Copy Back Program for a given plane must be between odd address pages or between even address pages for the device to meet the program time ( $t_{\text{PROG}}$ ) specification. Copy Back Program may not meet this specification when copying from an odd address page (source page) to an even address page (target page) or from an even address page (source page) to an odd address page (target page).

The data input cycle for modifying a portion or multiple distinct portions of the source page is allowed as shown in [Figure 6.15](#).

If a Copy Back Program operation is interrupted by hardware reset, power failure or other means, the host must ensure that the interrupted page is not used for further reading or programming operations until the next uninterrupted block erase is complete.

### 3.6.2 Special Read for Copy Back

The S34MS04G2 device supports Special Read for Copy Back. If Copy Back Read is triggered with confirm command '36h' instead '35h', Copy Back Read from target page(s) will be executed with an increased internal ( $V_{\text{PASS}}$ ) voltage.

This special feature is used in order to minimize the number of read errors due to over-program or read disturb — it shall be used only if ECC read errors have occurred in the source page using Page Read or Copy Back Read sequences.

### 3.7 Read Status Register

The Status Register is used to retrieve the status value for the last operation issued. After writing 70h command to the command register, a read cycle outputs the content of the Status Register to the I/O pins on the falling edge of CE# or RE#, whichever occurs last. This two-line control allows the system to poll the progress of each device in multiple memory connections even when R/B# pins are common-wired. Refer to Table 3.2 “Status Register Coding” for specific Status Register definition, and to Figure 6.16 for timings.

In other words, the Status Register is dynamic; the user is not required to toggle RE# / CE# to update it.

The command register remains in Status Read mode until further commands are issued. Therefore, if the Status Register is read during a random read cycle, the read command (00h) must be issued before starting read cycles.

Note: The Read Status Register command shall not be used for concurrent operations in multi-die stack configurations (single CE#). “Read Status Enhanced” shall be used instead.

### 3.8 Read Status Enhanced

Read Status Enhanced is used to retrieve the status value for a previous operation in the specified plane.

Figure 6.17 defines the Read Status Enhanced behavior and timings. The plane and die address must be specified in the command sequence in order to retrieve the status of the die and the plane of interest.

Refer to Table 3.2 for specific Status Register definitions. The command register remains in Status Read mode until further commands are issued.

The Status Register is dynamic; the user is not required to toggle RE# / CE# to update it.

### 3.9 Read Status Register Field Definition

Table 3.2 below lists the meaning of each bit of the Read Status Register and Read Status Enhanced.

**Table 3.2 Status Register Coding**

ID	Page Program / Page Reprogram	Block Erase	Read	Read Cache	Cache Program / Cache Reprogram	Coding
0	Pass / Fail	Pass / Fail	NA	NA	Pass / Fail	N Page Pass: 0 Fail: 1
1	NA	NA	NA	NA	Pass / Fail	N - 1 Page Pass: 0 Fail: 1
2	NA	NA	NA	NA	NA	—
3	NA	NA	NA	NA	NA	—
4	NA	NA	NA	NA	NA	—
5	Ready / Busy	Ready / Busy	Ready / Busy	Ready / Busy	Ready / Busy	Internal Data Operation Active: 0 Idle: 1
6	Ready / Busy	Ready / Busy	Ready / Busy	Ready / Busy	Ready / Busy	Ready / Busy Busy: 0 Ready: 1
7	Write Protect	Write Protect	NA	NA	Write Protect	Protected: 0 Not Protected: 1

### 3.10 Reset

The Reset feature is executed by writing FFh to the command register. If the device is in the Busy state during random read, program, or erase mode, the Reset operation will abort these operations. The contents of memory cells being altered are no longer valid, as the data may be partially programmed or erased. The command register is cleared to wait for the next command, and the Status Register is cleared to value E0h when WP# is high or value 60h when WP# is low. If the device is already in reset state a new Reset command will not be accepted by the command register. The R/B# pin transitions to low for  $t_{RST}$  after the Reset command is written. Refer to [Figure 6.18](#) for further details. The Status Register can also be read to determine the status of a Reset operation.

### 3.11 Read Cache

Read Cache can be used to increase the read operation speed, as defined in “Page Read” on page 12, and it cannot cross a block boundary. As soon as the user starts to read one page, the device automatically loads the next page into the cache register. Serial data output may be executed while data in the memory is read into the cache register. Read Cache is initiated by the Page Read sequence (00-30h) on a page M.

After random access to the first page is complete (R/B# returned to high, or Read Status Register I/O6 switches to high), two command sequences can be used to continue read cache:

- Read Cache (command ‘31h’ only): once the command is latched into the command register (see [Figure 6.20](#)), device goes busy for a short time ( $t_{CBSYR}$ ), during which data of the first page is transferred from the data register to the cache register. At the end of this phase, the cache register data can be output by toggling RE# while the next page (page address M+1) is read from the memory array into the data register.
- Read Cache Enhanced (sequence ‘00h’ <page N address> ‘31’): once the command is latched into the command register (see [Figure 6.21](#)), device goes busy for a short time ( $t_{CBSYR}$ ), during which data of the first page is transferred from the data register to the cache register. At the end of this phase, cache register data can be output by toggling RE# while page N is read from the memory array into the data register.

Subsequent pages are read by issuing additional Read Cache or Read Cache Enhanced command sequences. If serial data output time of one page exceeds random access time ( $t_R$ ), the random access time of the next page is hidden by data downloading of the previous page.

On the other hand, if 31h is issued prior to completing the random access to the next page, the device will stay busy as long as needed to complete random access to this page, transfer its contents into the cache register, and trigger the random access to the following page.

To terminate the Read Cache operation, 3Fh command should be issued (see [Figure 6.22](#)). This command transfers data from the data register to the cache register without issuing next page read.

During the Read Cache operation, the device doesn't allow any other command except for 00h, 31h, 3Fh, Read SR, or Reset (FFh). To carry out other operations, Read Cache must be terminated by the Read Cache End command (3Fh) or the device must be reset by issuing FFh.

Read Status command (70h) may be issued to check the status of the different registers and the busy/ready status of the cached read operations.

- The Cache-Busy status bit I/O6 indicates when the cache register is ready to output new data.
- The status bit I/O5 can be used to determine when the cell reading of the current data register contents is complete.

**Note:** The Read Cache and Read Cache End commands reset the column counter, thus, when RE# is toggled to output the data of a given page, the first output data is related to the first byte of the page (column address 00h). Random Data Output command can be used to switch column address.

### 3.12 Cache Program

Cache Program can improve the program throughput by using the cache register. The Cache Program operation cannot cross a block boundary. The cache register allows new data to be input while the previous data that was transferred to the data register is programmed into the memory array.

After the serial data input command (80h) is loaded to the command register, followed by five cycles of address, a full or partial page of data is latched into the cache register.

Once the cache write command (15h) is loaded to the command register, the data in the cache register is transferred into the data register for cell programming. At this time the device remains in the Busy state for a short time ( $t_{CBSYW}$ ). After all data of the cache register is transferred into the data register, the device returns to the Ready state and allows loading the next data into the cache register through another Cache Program command sequence (80h-15h).

The Busy time following the first sequence 80h - 15h equals the time needed to transfer the data from the cache register to the data register. Cell programming the data of the data register and loading of the next data into the cache register is consequently processed through a pipeline model.

In case of any subsequent sequence 80h - 15h, transfer from the cache register to the data register is held off until cell programming of current data register contents is complete; till this moment the device will stay in a busy state ( $t_{CBSYW}$ ).

Read Status commands (70h or 78h) may be issued to check the status of the different registers, and the pass/fail status of the cached program operations.

- The Cache-Busy status bit I/O6 indicates when the cache register is ready to accept new data.
- The status bit I/O5 can be used to determine when the cell programming of the current data register contents is complete.
- The Cache Program error bit I/O1 can be used to identify if the previous page (page N-1) has been successfully programmed or not in a Cache Program operation. The status bit is valid upon I/O6 status bit changing to 1.
- The error bit I/O0 is used to identify if any error has been detected by the program/erase controller while programming page N. The status bit is valid upon I/O5 status bit changing to 1.

I/O1 may be read together with I/O0.

If the system monitors the progress of the operation only with R/B#, the last page of the target program sequence must be programmed with Page Program Confirm command (10h). If the Cache Program command (15h) is used instead, the status bit I/O5 must be polled to find out if the last programming is finished before starting any other operation. See [Table 3.2](#) and [Figure 6.23](#) for more details.

If a Cache Program operation is interrupted by hardware reset, power failure or other means, the host must ensure that the interrupted pages are not used for further reading or programming operations until the next uninterrupted block erases are complete for the applicable blocks.



### 3.13 Read ID

The device contains a product identification mode, initiated by writing 90h to the command register, followed by an address input of 00h.

**Note:** If you want to execute Read Status command (0x70) after Read ID sequence, you should input dummy command (0x00) before Read Status command (0x70).

For the S34MS04G2 device, five read cycles sequentially output the manufacturer code (01h), and the device code and 3rd, 4th, and 5th cycle ID, respectively. The command register remains in Read ID mode until further commands are issued to it.

Figure 6.24 shows the operation sequence, while Table 3.3 to Table 3.7 explain the byte meaning.

**Table 3.3 Read ID for Supported Configurations**

Density	Org	V <sub>CC</sub>	1st	2nd	3rd	4th	5th
4 Gb	x8	1.8V	01h	ACh	80h	16h	20h

**Table 3.4 Read ID Bytes**

Device Identifier Byte	Description
1st	Manufacturer Code
2nd	Device Identifier
3rd	Internal chip number, cell type, etc.
4th	Page Size, Block Size, Spare Size, Serial Access Time, Organization
5th	ECC, Multiplane information

### 3<sup>rd</sup> ID Data

**Table 3.5 Read ID Byte 3 Description**

	Description	I/O7	I/O6	I/O5 I/O4	I/O3 I/O2	I/O1 I/O0
Internal Chip Number	1					0 0
	2					0 1
	4					1 0
	8					1 1
Cell type	2-level cell				0 0	
	4-level cell				0 1	
	8-level cell				1 0	
	16-level cell				1 1	
Number of simultaneously programmed pages	1			0 0		
	2			0 1		
	4			1 0		
	8			1 1		
Interleave program Between multiple chips	Not supported		0			
	Supported		1			
Cache Program	Not supported	0				
	Supported	1				

### 4<sup>th</sup> ID Data

**Table 3.6 Read ID Byte 4 Description**

	Description	I/O7	I/O6	I/O5 I/O4	I/O3	I/O2	I/O1 I/O0
Page Size (without spare area)	4 KB						1 0
Block Size (without spare area)	256 KB			0 1			
Spare Area Size (byte / 512 byte)	32					1	
Serial Access Time	45 ns	0			0		
Organization	x8		0				

### 5<sup>th</sup> ID Data

**Table 3.7 Read ID Byte 5 Description**

	Description	I/O7	I/O6 I/O5 I/O4	I/O3 I/O2	I/O1 I/O0
ECC Level	4 bit / 512 bytes				0 0
Plane Number	1			0 0	
Plane Size (without spare area)	4 Gb		0 1 0		
Reserved		0			

### 3.14 Read ID2

The device contains an alternate identification mode, initiated by writing 30h-65h-00h to the command register, followed by address inputs, followed by command 30h. The address for S34MS04G2 will be 00h-02h-02h-00h-00h. The ID2 data can then be read from the device by pulsing RE#. The command register remains in Read ID2 mode until further commands are issued to it.

[Figure 6.25](#) shows the Read ID2 command sequence. Read ID2 values are all 0xFs, unless specific values are requested when ordering from SkyHigh.

### 3.15 Read ONFI Signature

To retrieve the ONFI signature, the command 90h together with an address of 20h shall be entered (i.e. it is not valid to enter an address of 00h and read 36 bytes to get the ONFI signature). The ONFI signature is the ASCII encoding of 'ONFI' where 'O' = 4Fh, 'N' = 4Eh, 'F' = 46h, and 'I' = 49h. Reading beyond four bytes yields indeterminate values. [Figure 6.26](#) shows the operation sequence.

### 3.16 Read Parameter Page

The device supports the ONFI Read Parameter Page operation, initiated by writing ECh to the command register, followed by an address input of 00h. The host may monitor the R/B# pin or wait for the maximum data transfer time ( $t_{\text{R}}$ ) before reading the Parameter Page data. The command register remains in Parameter Page mode until further commands are issued to it. If the Status Register is read to determine when the data is ready, the Read Command (00h) must be issued before starting read cycles.

[Figure 6.27](#) shows the operation sequence, while [Table 3.8](#) explains the parameter fields.

**Note:** For 32nm SkyHigh NAND, for a particular condition, the Read Parameter Page command does not give the correct values. To overcome this issue, the host must issue a Reset command before the Read Parameter Page command. Issuance of Reset before the Read Parameter Page command will provide the correct values and will not output 00h values.

**Table 3.8 Parameter Page Description**

Byte	O/M	Description	Values
<b>Revision Information and Features Block</b>			
0-3	M	Parameter page signature Byte 0: 4Fh, "O" Byte 1: 4Eh, "N" Byte 2: 46h, "F" Byte 3: 49h, "I"	4Fh, 4Eh, 46h, 49h
4-5	M	Revision number 2-15 Reserved (0) 1 1 = supports ONFI version 1.0 0 Reserved (0)	02h, 00h
6-7	M	Features supported 5-15 Reserved (0) 4 1 = supports odd to even page Copyback 3 1 = supports interleaved operations 2 1 = supports non-sequential page programming 1 1 = supports multiple LUN operations 0 1 = supports 16-bit data bus width	S34MS04G200 (x8): 10h, 00h
8-9	M	Optional commands supported 6-15 Reserved (0) 5 1 = supports Read Unique ID (contact factory) 4 1 = supports Copyback 3 1 = supports Read Status Enhanced 2 1 = supports Get Features and Set Features 1 1 = supports Read Cache commands 0 1 = supports Page Cache Program command	S34MS04G2: 3Bh, 00h
10-31		Reserved (0)	00h
<b>Manufacturer Information Block</b>			
32-43	M	Device manufacturer (12 ASCII characters)	53h, 50h, 41h, 4Eh, 53h, 49h, 4Fh, 4Eh, 20h, 20h, 20h, 20h
44-63	M	Device model (20 ASCII characters)	S34MS04G2: 53h, 33h, 34h, 4Dh, 53h, 30h, 34h, 47h, 32h, 20h, 20h, 20h, 20h, 20h, 20h, 20h, 20h, 20h, 20h, 20h, 20h
64	M	JEDEC manufacturer ID	01h
65-66	O	Date code	00h
67-79		Reserved (0)	00h
<b>Memory Organization Block</b>			
80-83	M	Number of data bytes per page	00h, 10h, 00h, 00h
84-85	M	Number of spare bytes per page	00h, 01h
86-89	M	Number of data bytes per partial page	00h, 00h, 00h, 00h
90-91	M	Number of spare bytes per partial page	00h, 00h
92-95	M	Number of pages per block	40h, 00h, 00h, 00h
96-99	M	Number of blocks per logical unit (LUN)	00h, 08h, 00h, 00h

**Table 3.9 Parameter Page Description (Continued)**

Byte	O/M	Description	Values
100	M	Number of logical units (LUNs)	01h
101	M	Number of address cycles 4-7 Column address cycles 0-3 Row address cycles	23h
102	M	Number of bits per cell	01h
103-104	M	Bad blocks maximum per LUN	28h, 00h
105-106	M	Block endurance	01h, 05h
107	M	Guaranteed valid blocks at beginning of target	01h
108-109	M	Block endurance for guaranteed valid blocks	01h, 03h
110	M	Number of programs per page	04h
111	M	Partial programming attributes 5-7 Reserved 4 1 = partial page layout is partial page data followed by partial page spare 1-3 Reserved 0 1 = partial page programming has constraints	00h
112	M	Number of bits ECC correctability	04h
113	M	Number of interleaved address bits 4-7 Reserved (0) 0-3 Number of interleaved address bits	01h
114	O	Interleaved operation attributes 4-7 Reserved (0) 3 Address restrictions for program cache 2 1 = program cache supported 1 1 = no block address restrictions 0 Overlapped / concurrent interleaving support	S34MS04G2: 04h
115-127		Reserved (0)	00h
<b>Electrical Parameters Block</b>			
128	M	I/O pin capacitance	0Ah
129-130	M	Timing mode support 6-15 Reserved (0) 5 1 = supports timing mode 5 4 1 = supports timing mode 4 3 1 = supports timing mode 3 2 1 = supports timing mode 2 1 1 = supports timing mode 1 0 1 = supports timing mode 0, shall be 1	03h, 00h
131-132	O	Program cache timing mode support 6-15 Reserved (0) 5 1 = supports timing mode 5 4 1 = supports timing mode 4 3 1 = supports timing mode 3 2 1 = supports timing mode 2 1 1 = supports timing mode 1 0 1 = supports timing mode 0	03h, 00h
133-134	M	$t_{\text{PROG}}$ Maximum page program time ( $\mu\text{s}$ )	BCh, 02h
135-136	M	$t_{\text{BERS}}$ Maximum block erase time ( $\mu\text{s}$ )	10h, 27h
137-138	M	$t_{\text{R}}$ Maximum page read time ( $\mu\text{s}$ )	1Eh, 00h
139-140	M	$t_{\text{CCS}}$ Minimum Change Column setup time (ns)	C8h, 00h

**Table 3.9 Parameter Page Description (Continued)**

Byte	O/M	Description	Values
141-163		Reserved (0)	00h
<b>Vendor Block</b>			
164-165	M	Vendor specific Revision number	00h
166-253		Vendor specific	00h
254-255	M	Integrity CRC	CCh, 69h
<b>Redundant Parameter Pages</b>			
256-511	M	Value of bytes 0-255	Repeat Value of bytes 0-255
512-767	M	Value of bytes 0-255	Repeat Value of bytes 0-255
768+	O	Additional redundant parameter pages	FFh

**Note:**

1. "O" Stands for Optional, "M" for Mandatory.

### 3.17 Read Unique ID (Contact Factory)

The device supports the ONFI Read Unique ID function, initiated by writing EDh to the command register, followed by an address input of 00h. The host must monitor the R/B# pin or wait for the maximum data transfer time ( $t_R$ ) before reading the Unique ID data. The first sixteen bytes returned by the flash is a unique value. The next sixteen bytes returned are the bit-wise complement of the unique value. The host can verify the Unique ID was read correctly by performing an XOR of the two values. The result should be all ones. The command register remains in Unique ID mode until further commands are issued to it. [Figure 6.28](#) shows the operation sequence, while [Table 3.9](#) shows the Unique ID data contents. SkyHigh guarantees unique id support feature with a special model number shown in the OPN combination in "[Ordering Information](#)".

**Note:** For 32nm SkyHigh NAND, for a particular condition, the Read Unique ID command does not give the correct values. To overcome this issue, the host must issue a Reset command before the Read Unique ID command. Issuance of Reset before the Read Unique ID command will provide the correct values and will not output 00h values.

**Table 3.9 Unique ID Data Description (Contact Factory)**

Byte	Description
0-15	Unique ID
16-31	ID Complement
32-47	Unique ID
48-63	ID Complement
64-79	Unique ID
80-95	ID Complement
96-111	Unique ID
112-127	ID Complement
128-143	Unique ID
144-159	ID Complement
160-175	Unique ID
176-191	ID Complement
192-207	Unique ID
208-223	ID Complement
224-239	Unique ID

**Table 3.9 Unique ID Data Description (Contact Factory) (Continued)**

Byte	Description
240-255	ID Complement
256-271	Unique ID
272-287	ID Complement
288-303	Unique ID
304-319	ID Complement
320-335	Unique ID
336-351	ID Complement
352-367	Unique ID
368-383	ID Complement
384-399	Unique ID
400-415	ID Complement
416-431	Unique ID
432-447	ID Complement
448-463	Unique ID
464-479	ID Complement
480-495	Unique ID
496-511	ID Complement

### 3.18 One-Time Programmable (OTP) Entry

The device contains a one-time programmable (OTP) area, which is accessed by writing 29h-17h-04h-19h to the command register. The device is then ready to accept Page Read and Page Program commands (refer to [Page Read](#) and ["Page Program"](#)). The OTP area is of a single erase block size (64 pages), and hence only row addresses between 00h and 3Fh are allowed. The host must issue the Reset command (refer to ["Reset"](#)) to exit the OTP area and access the normal flash array. The BlockErase command is not allowed in the OTP area. Refer to [Figure 6.29](#) for more detail on the OTP Entry command sequence.



### 4. Signal Descriptions

#### 4.1 Data Protection and Power On / Off Sequence

The device is designed to offer protection from any involuntary program/erase during power-transitions. An internal voltage detector disables all functions whenever  $V_{CC}$  is below about 1.1V.

The power-up and power-down sequence is shown in Figure 6.30, in this case  $V_{CC}$  and  $V_{CCQ}$  on the one hand (and  $V_{SS}$  and  $V_{SSQ}$  on the other hand) are shorted together at all times.

The Ready/Busy signal shall be valid within 100  $\mu$ s after the power supplies have reached the minimum values (as specified on), and shall return to one within 5 ms (max).

During this busy time, the device executes the initialization process (cam reading), and dissipates a current  $I_{CC0}$  (30 mA max), in addition, it disregards all commands excluding Read Status Register (70h).

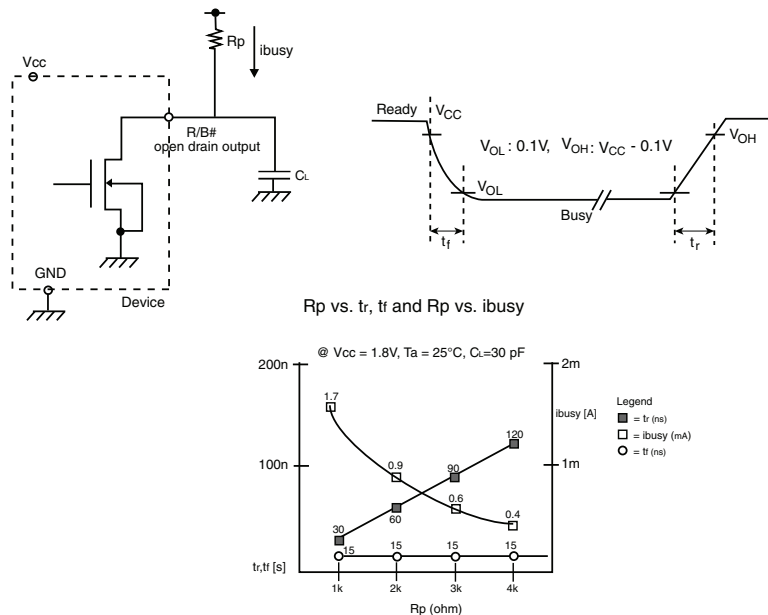
At the end of this busy time, the device defaults into "read setup", thus if the user decides to issue a page read command, the 00h command may be skipped.

The WP# pin provides hardware protection and is recommended to be kept at  $V_{IL}$  during power-up and power-down. A recovery time of minimum 100  $\mu$ s is required before the internal circuit gets ready for any command sequences as shown in Figure 6.30. The two-step command sequence for program/erase provides additional software protection.

#### 4.2 Ready/Busy

The Ready/Busy output provides a method of indicating the completion of a page program, erase, copyback, or read completion. The R/B# pin is normally high and goes to low when the device is busy (after a reset, read, program, or erase operation). It returns to high when the internal controller has finished the operation. The pin is an open-drain driver thereby allowing two or more R/B# outputs to be Or-tied. Because the pull-up resistor value is related to  $t_r$  (R/B#) and the current drain during busy ( $i_{busy}$ ), and output load capacitance is related to  $t_f$ , an appropriate value can be obtained with the reference chart shown in Figure 4.1.

Figure 4.1 Ready/Busy Pin Electrical Application



Rp value guidance

$$R_p (\text{min.}) = \frac{V_{CC} (\text{Max.}) - V_{OL} (\text{Max.})}{I_{OL} + \sum I_L} = \frac{1.85V}{3mA + \sum I_L}$$

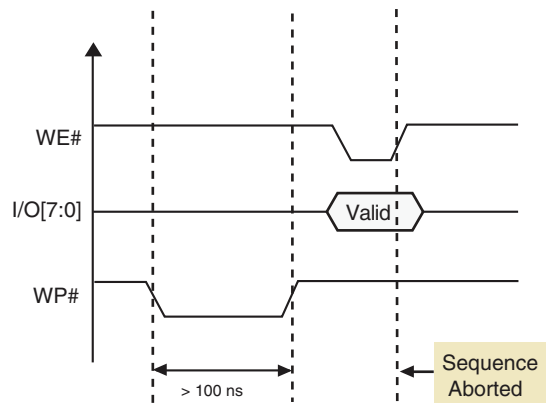
where  $I_L$  is the sum of the input currents of all devices tied to the R/B# pin.  
 $R_p(\text{max})$  is determined by maximum permissible limit of  $t_r$ .

### 4.3 Write Protect Operation

Erase and program operations are aborted if WP# is driven low during busy time, and kept low for about 100 ns. Switching WP# low during this time is equivalent to issuing a Reset command (FFh). The contents of memory cells being altered are no longer valid, as the data will be partially programmed or erased. The R/B# pin will stay low for  $t_{RST}$  (similarly to Figure 6.18). At the end of this time, the command register is ready to process the next command, and the Status Register bit I/O6 will be cleared to 1, while I/O7 value will be related to the WP# value. Refer to Table 3.2 for more information on device status.

Erase and program operations are enabled or disabled by setting WP# to high or low respectively, prior to issuing the setup commands (80h or 60h). The level of WP# shall be set  $t_{WV}$  ns prior to raising the WE# pin for the set up command, as explained in Figure 6.31 and Figure 6.32.

**Figure 4.2 WP# Low Timing Requirements during Program/Erase Command Sequence**



## 5. Electrical Characteristics

### 5.1 Valid Blocks

Table 5.1 Valid Blocks

Device	Symbol	Min	Typ	Max	Unit
S34MS04G2	$N_{VB}$	2008	—	2048	Blocks

### 5.2 Absolute Maximum Ratings

Table 5.2 Absolute Maximum Ratings

Parameter	Symbol	Value	Unit
Ambient Operating Temperature (Industrial Temperature Range)	$T_A$	-40 to +85	°C
Temperature under Bias	$T_{BIAS}$	-50 to +125	°C
Storage Temperature	$T_{STG}$	-65 to +150	°C
Input or Output Voltage	$V_{IO}$ (2)	-0.6 to +2.7	V
Supply Voltage	$V_{CC}$	-0.6 to +2.7	V

**Notes:**

1. Except for the rating "Operating Temperature Range", stresses above those listed in the table [Absolute Maximum Ratings](#) may cause permanent damage to the device. These are stress ratings only and operation of the device at these or any other conditions above those indicated in the Operating sections of this specification is not implied. Exposure to Absolute Maximum Rating conditions for extended periods may affect device reliability.
2. Minimum Voltage may undershoot to -2V during transition and for less than 20 ns during transitions.
3. Maximum Voltage may overshoot to  $V_{CC} + 2.0V$  during transition and for less than 20 ns during transitions.

### 5.3 AC Test Conditions

Table 5.3 AC Test Conditions

Parameter	Value
Input Pulse Levels	0.0V to $V_{CC}$
Input Rise And Fall Times	5 ns
Input And Output Timing Levels	$V_{CC} / 2$
Output Load (1.7V - 1.95V)	1 TTL Gate and CL = 30 pF

### 5.4 AC Characteristics

Table 5.4 AC Characteristics

Parameter	Symbol	Min	Max	Unit
ALE to RE# delay	$t_{AR}$	10	—	ns
ALE hold time	$t_{ALH}$	10	—	ns
ALE setup time	$t_{ALS}$	25	—	ns
Address to data loading time	$t_{ADL}$	100	—	ns
CE# Access Time	$t_{CEA}$ (4)	—	45	ns
CE# low to RE# low	$t_{CR}$	10	—	ns
CE# hold time	$t_{CH}$	10	—	ns
CE# high to output High-Z	$t_{CHZ}$	—	30	ns
CLE hold time	$t_{CLH}$	10	—	ns
CLE to RE# delay	$t_{CLR}$	10	—	ns
CLE setup time	$t_{CLS}$	25	—	ns
CE# high to output hold	$t_{COH}$ (3)	15	—	ns
CE# high to ALE or CLE don't care	$t_{CSD}$	10	—	ns
CE# setup time	$t_{CS}$	35	—	ns
Data hold time	$t_{DH}$	10	—	ns
Data setup time	$t_{DS}$	20	—	ns
Data transfer from cell to register	$t_R$	—	30	$\mu$ s
Output High-Z to RE# low	$t_{IR}$	0	—	ns
Read cycle time	$t_{RC}$	45	—	ns
RE# access time	$t_{REA}$	—	30	ns
RE# high hold time	$t_{REH}$	15	—	ns
RE# high to output hold	$t_{RHOH}$ (3)	15	—	ns
RE# high to WE# low	$t_{RHW}$	100	—	ns
RE# high to output High-Z	$t_{RHZ}$	—	100	ns
RE# low to output hold	$t_{RLOH}$ (5)	—	—	ns
RE# pulse width	$t_{RP}$	25	—	ns
Ready to RE# low	$t_{RR}$	20	—	ns
Device resetting time (Read/Program/Erase)	$t_{RST}$	—	5/10/500 (2)	$\mu$ s
WE# high to busy	$t_{WB}$	—	100	ns
Write cycle time	$t_{WC}$	45	—	ns
WE# high hold time	$t_{WH}$	15	—	ns
WE# high to RE# low	$t_{WHR}$	60	—	ns
WE# high to RE# low for Random data out	$t_{WHR2}$	200	—	ns
WE# pulse width	$t_{WP}$	25	—	ns
Write protect time	$t_{WW}$	100	—	ns

**Notes:**

1. The time to Ready depends on the value of the pull-up resistor tied to R/B# pin.
2. If Reset Command (FFh) is written at Ready state, the device goes into Busy for maximum 5  $\mu$ s.
3. CE# low to high or RE# low to high can be at different times and produce three cases. Depending on which signal comes high first, either  $t_{COH}$  or  $t_{RHOH}$  will be met.

4. During data output,  $t_{CEA}$  depends partly on  $t_{CR}$  (CE# low to RE# low). If  $t_{CR}$  exceeds the minimum value specified, then the maximum time for  $t_{CEA}$  may also be exceeded ( $t_{CEA} = t_{CR} + t_{REA}$ ).
5.  $t_{RLOH}$  is only relevant for EDO timing ( $t_{RC} < 30$  ns), which does not apply for this device.

## 5.5 DC Characteristics

**Table 5.5 DC Characteristics and Operating Conditions**

Parameter	Symbol	Test Conditions	Min	Typ	Max	Units
Power-On-Reset Current	$I_{CC0}$	FFh command input after power on	—	—	50 per device	mA
Operating Current	Read	$t_{RC} = t_{RC}(\text{min})$ CE# = $V_{IL}$ , $I_{OUT} = 0$ mA	—	15	30	mA
	Program	Normal	—	15	30	mA
		Cache	—	—	15	30
Erase	$I_{CC3}$	—	—	15	30	mA
Standby Current, (TTL)	$I_{CC4}$	CE# = $V_{IH}$ , WP# = $0V/V_{CC}$	—	—	1	mA
Standby Current, (CMOS)	$I_{CC5}$	CE# = $V_{CC} - 0.2$ , WP# = $0/V_{CC}$	—	10	50	$\mu$ A
Input Leakage Current	$I_{LI}$	$V_{IN} = 0$ to $V_{CC}(\text{max})$	—	—	$\pm 10$	$\mu$ A
Output Leakage Current	$I_{LO}$	$V_{OUT} = 0$ to $V_{CC}(\text{max})$	—	—	$\pm 10$	$\mu$ A
Input High Voltage	$V_{IH}$	—	$V_{CC} \times 0.8$	—	$V_{CC} + 0.3$	V
Input Low Voltage	$V_{IL}$	—	-0.3	—	$V_{CC} \times 0.2$	V
Output High Voltage	$V_{OH}$	$I_{OH} = -100 \mu$ A	$V_{CC} - 0.1$	—	—	V
Output Low Voltage	$V_{OL}$	$I_{OL} = 100 \mu$ A	—	—	0.1	V
Output Low Current (R/B#)	$I_{OL(R/B\#)}$	$V_{OL} = 0.1V$	3	4	—	mA
Erase and Program Lockout Voltage	$V_{LKO}$	—	—	1.1	—	V

**Notes:**

1. All  $V_{CC}$  pins, and  $V_{SS}$  pins respectively, are shorted together.
2. Values listed in this table refer to the complete voltage range for  $V_{CC}$  and to a single device in case of device stacking.
3. All current measurements are performed with a  $0.1 \mu$ F capacitor connected between the  $V_{CC}$  Supply Voltage pin and the  $V_{SS}$  Ground pin.
4. Standby current measurement can be performed after the device has completed the initialization process at power up. Refer to [Data Protection and Power On / Off Sequence](#) for more details.

### 5.6 Pin Capacitance

**Table 5.6 Pin Capacitance (TA = 25°C, f=1.0 MHz)**

Parameter	Symbol	Test Condition	Min	Max	Unit
Input	C <sub>IN</sub>	V <sub>IN</sub> = 0V	—	10	pF
Input / Output	C <sub>IO</sub>	V <sub>IL</sub> = 0V	—	10	pF

**Note:**

1. For the stacked devices version the Input is 10 pF x [number of stacked chips] and the Input/Output is 10 pF x [number of stacked chips].

### 5.7 Program / Erase Characteristics

**Table 5.7 Program / Erase Characteristics**

Parameter	Description	Min	Typ	Max	Unit
Program Time (2)	t <sub>PROG</sub>	—	300	700	μs
Cache Program short busy time	t <sub>CBSYW</sub>	—	5	t <sub>PROG</sub>	μs
Number of partial Program Cycles in the same page	Main + Spare NOP	—	—	4	Cycle
Block Erase Time (	t <sub>BERS</sub>	—	3.5	10	ms
Read Cache busy time	t <sub>CBSYR</sub>	—	5	t <sub>R</sub>	μs

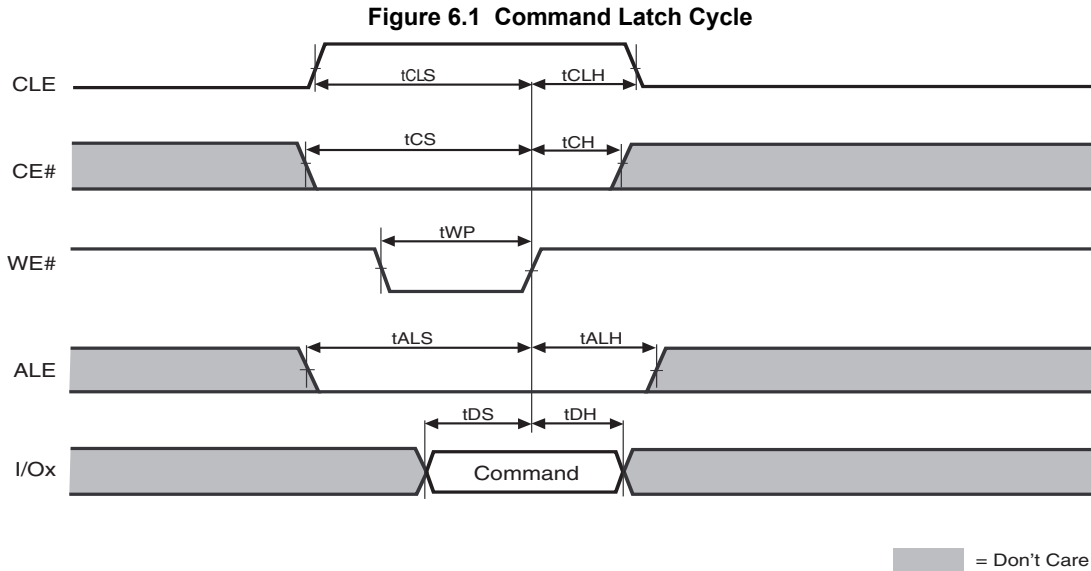
**Notes:**

1. Typical program time is defined as the time within which more than 50% of the whole pages are programmed (V<sub>CC</sub> = 1.8V, 25°C).
2. Copy Back Read and Copy Back Program for a given plane must be between odd address pages or between even address pages for the device to meet the program time (t<sub>PROG</sub>) specification. Copy Back Program may not meet this specification when copying from an odd address page (source page) to an even address page (target page) or from an even address page (source page) to an odd address page (target page).

## 6. Timing Diagrams

### 6.1 Command Latch Cycle

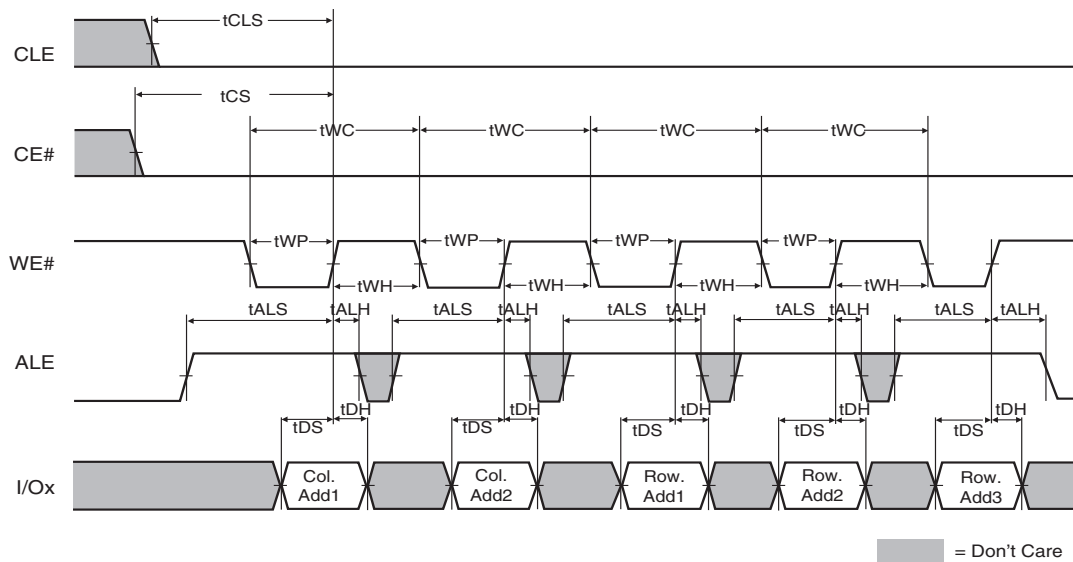
Command Input bus operation is used to give a command to the memory device. Commands are accepted with Chip Enable low, Command Latch Enable High, Address Latch Enable low, and Read Enable High and latched on the rising edge of Write Enable. Moreover for commands that starts a modify operation (write/ erase) the Write Protect pin must be high.



### 6.2 Address Latch Cycle

Address Input bus operation allows the insertion of the memory address. To insert the 27 (x8 Device) addresses needed to access the 1 Gb, four write cycles are needed. Addresses are accepted with Chip Enable low, Address Latch Enable High, Command Latch Enable low, and Read Enable High and latched on the rising edge of Write Enable. Moreover, for commands that start a modify operation (write/ erase) the Write Protect pin must be high.

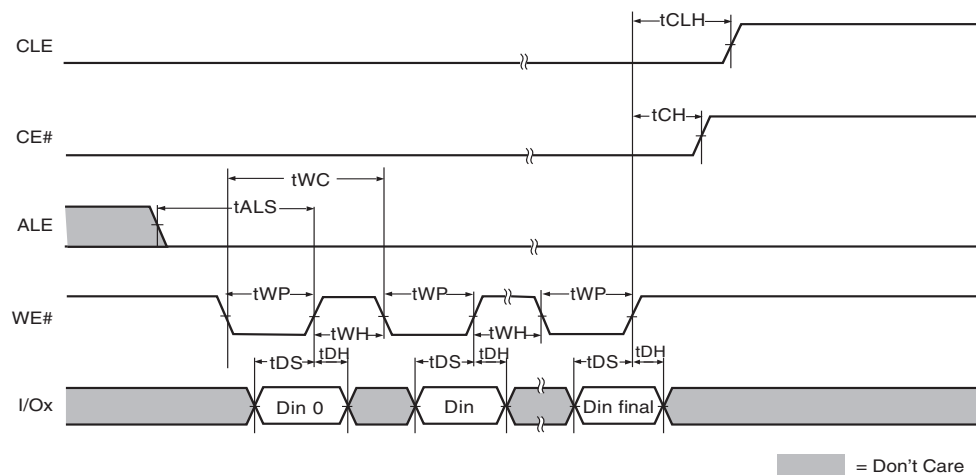
Figure 6.2 Address Latch Cycle



### 6.3 Data Input Cycle Timing

Data Input bus operation allows the data to be programmed to be sent to the device. The data insertion is serially, and timed by the Write Enable cycles. Data is accepted only with Chip Enable low, Address Latch Enable low, Command Latch Enable low, Read Enable High, and Write Protect High and latched on the rising edge of Write Enable.

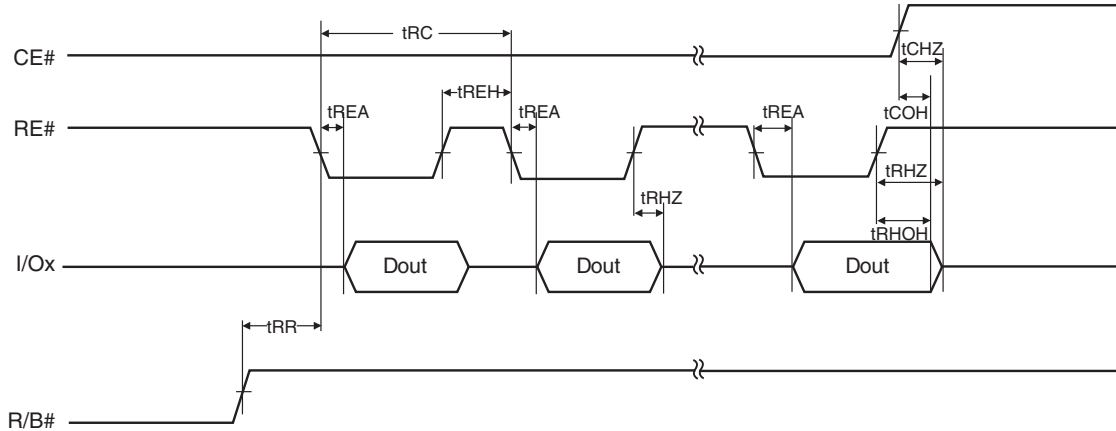
Figure 6.3 Input Data Latch Cycle





### 6.4 Data Output Cycle Timing (CLE=L, WE#=H, ALE=L, WP#=H)

Figure 6.4 Data Output Cycle Timing

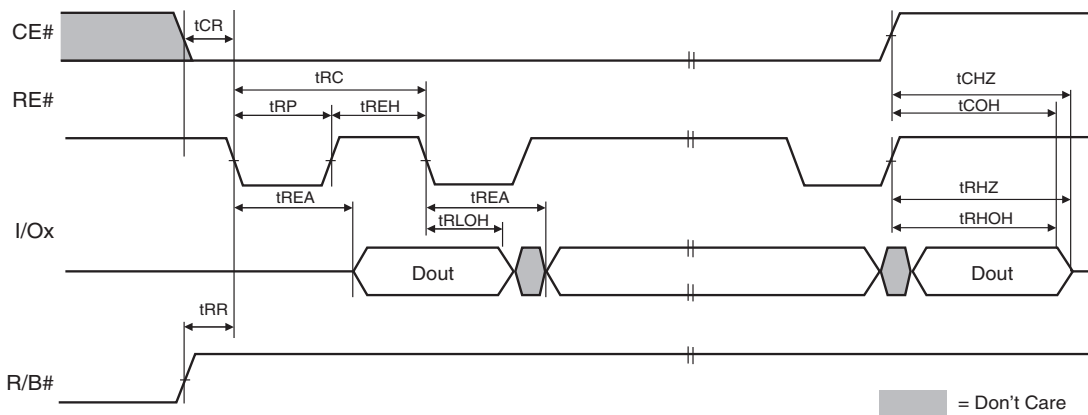


**Notes:**

1. Transition is measured at  $\pm 200$  mV from steady state voltage with load.
2. This parameter is sampled and not 100% tested.
3.  $t_{RHOH}$  starts to be valid when frequency is lower than 33 MHz.

### 6.5 Data Output Cycle Timing (EDO Type, CLE=L, WE#=H, ALE=L)

Figure 6.5 Data Output Cycle Timing (EDO)

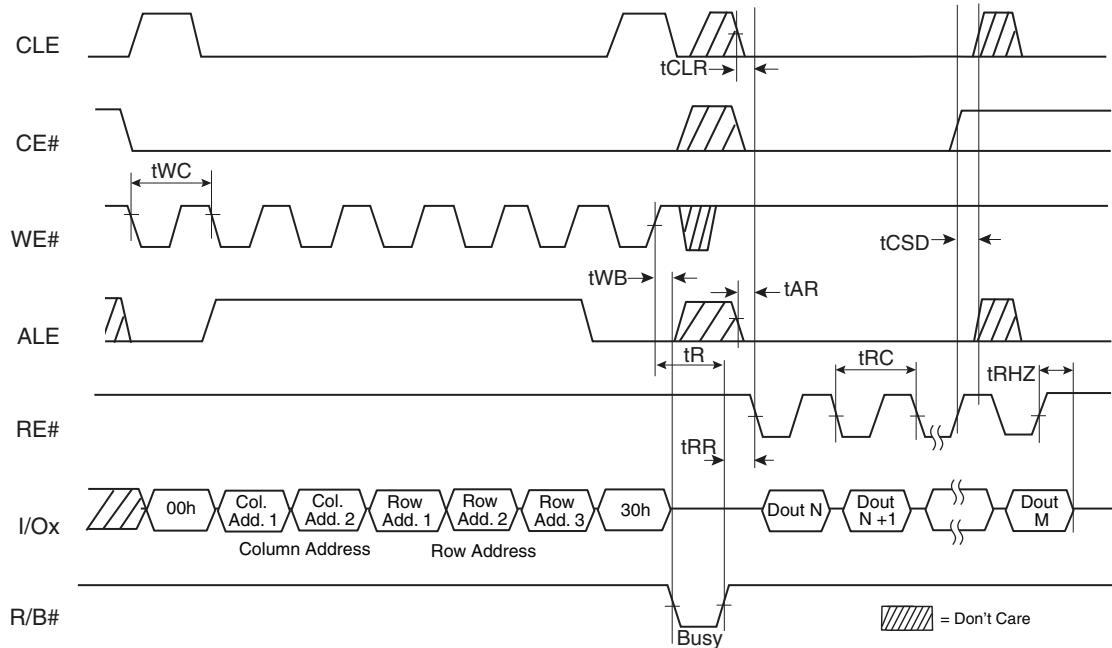


**Notes:**

1. Transition is measured at  $\pm 200$  mV from steady state voltage with load.
2. This parameter is sampled and not 100% tested.
3.  $t_{RLOH}$  is valid when frequency is higher than 33 MHz.
4.  $t_{RHOH}$  starts to be valid when frequency is lower than 33 MHz.

### 6.6 Page Read Operation

Figure 6.6 Page Read Operation (Read One Page)

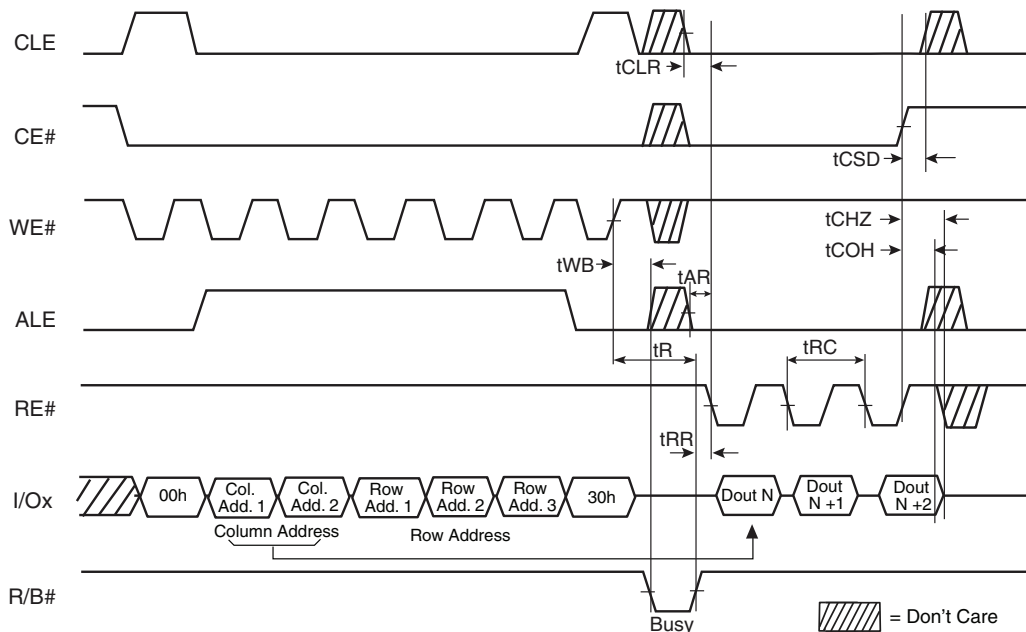


**Note:**

1. If Status Register polling is used to determine completion of the read operation, the Read Command (00h) must be issued before data can be read from the page buffer.

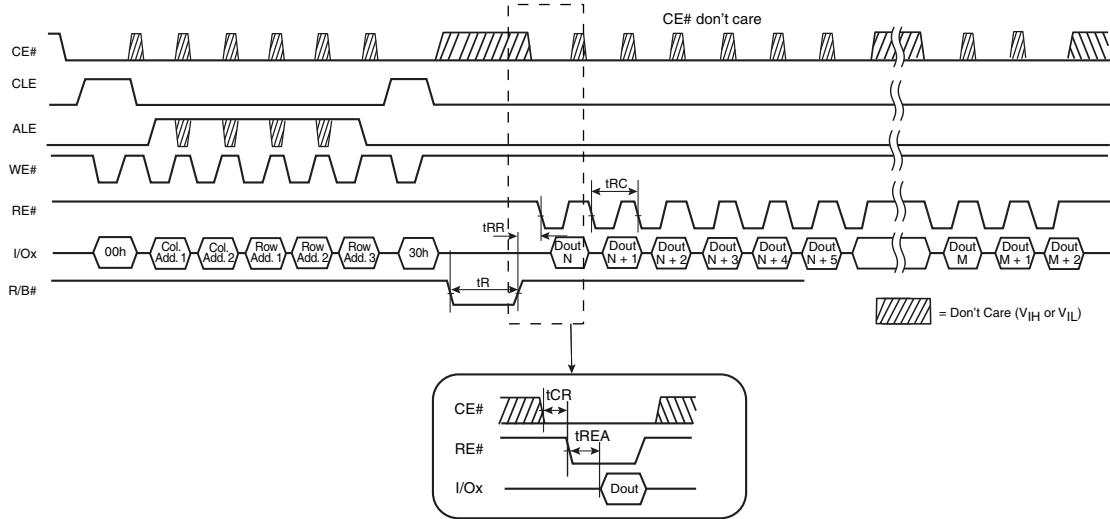
### 6.7 Page Read Operation (Interrupted by CE#)

Figure 6.7 Page Read Operation Interrupted by CE#



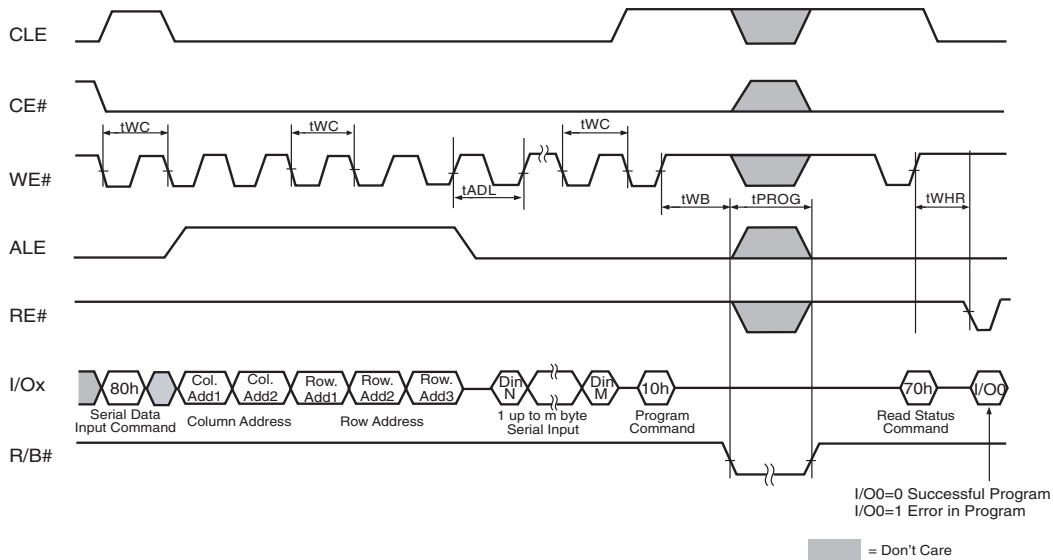
### 6.8 Page Read Operation Timing with CE# Don't Care

Figure 6.8 Page Read Operation Timing with CE# Don't Care



### 6.9 Page Program Operation

Figure 6.9 Page Program Operation

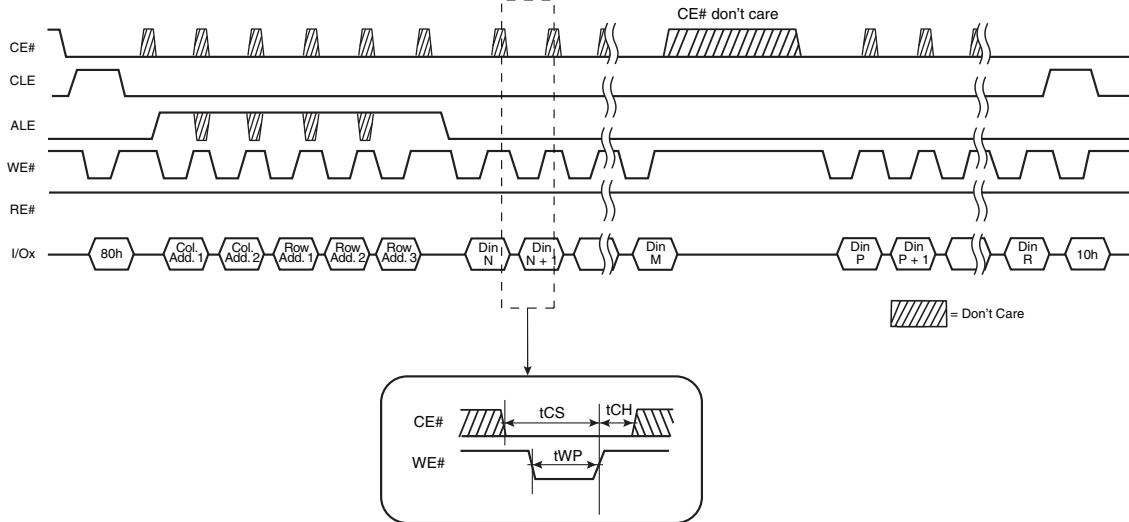


**Note:**

1.  $t_{ADL}$  is the time from the WE# rising edge of final address cycle to the WE# rising edge of first data cycle.

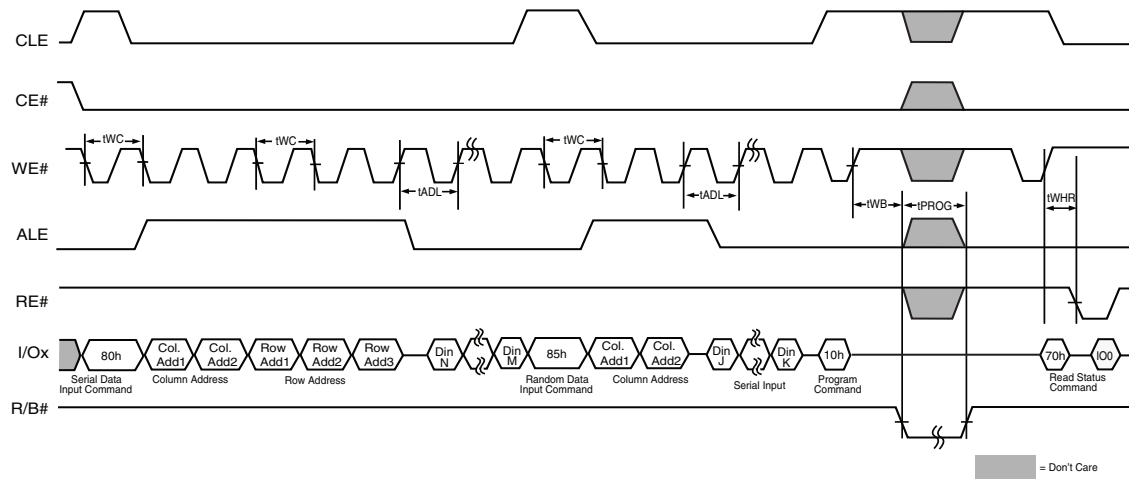
### 6.10 Page Program Operation Timing with CE# Don't Care

Figure 6.10 Page Program Operation Timing with CE# Don't Care



### 6.11 Page Program Operation with Random Data Input

Figure 6.11 Random Data Input

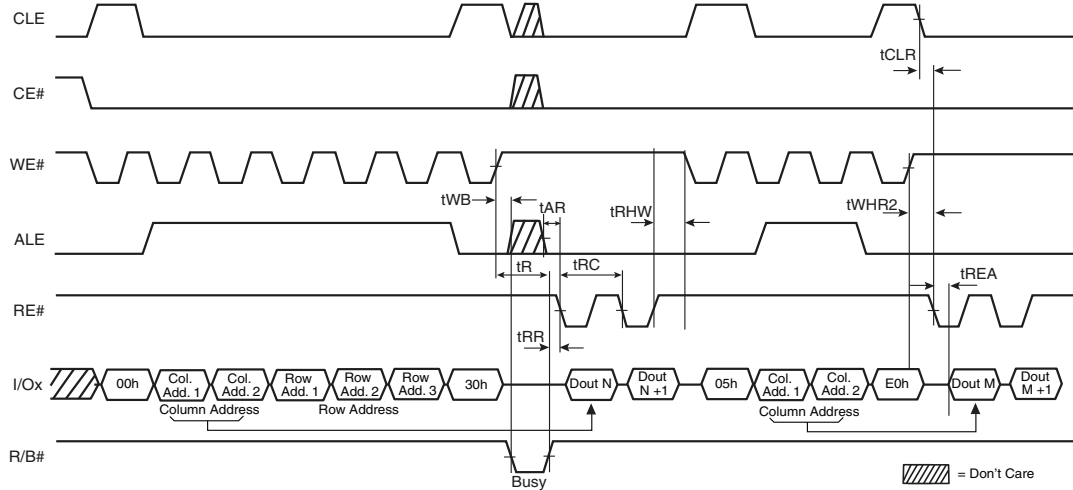


**Note:**

- $t_{ADL}$  is the time from the WE# rising edge of final address cycle to the WE# rising edge of first data cycle.

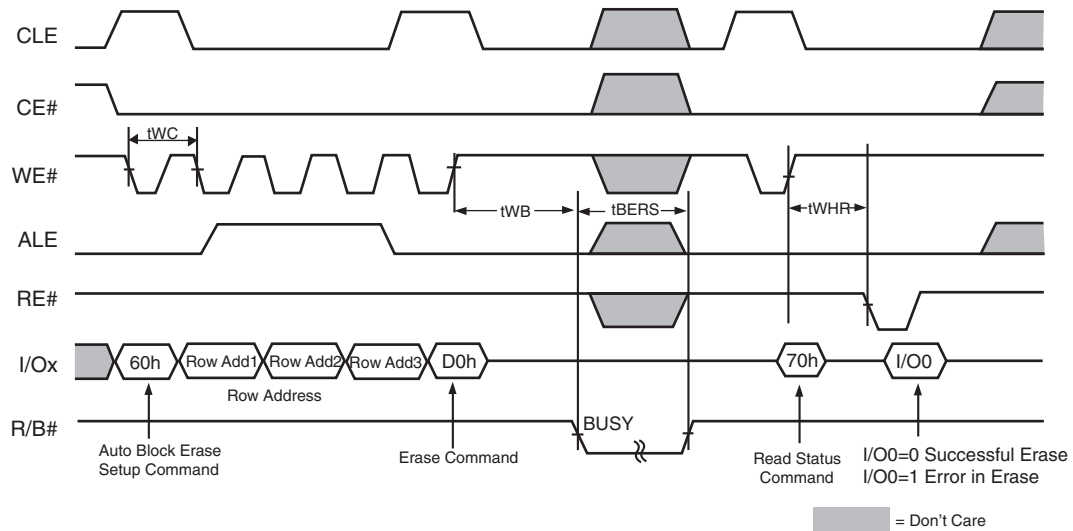
### 6.12 Random Data Output In a Page

Figure 6.12 Random Data Output



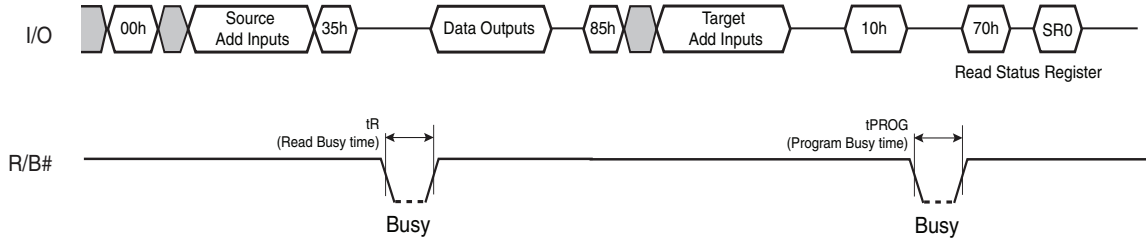
### 6.13 Block Erase Operation

Figure 6.13 Block Erase Operation (Erase One Block)



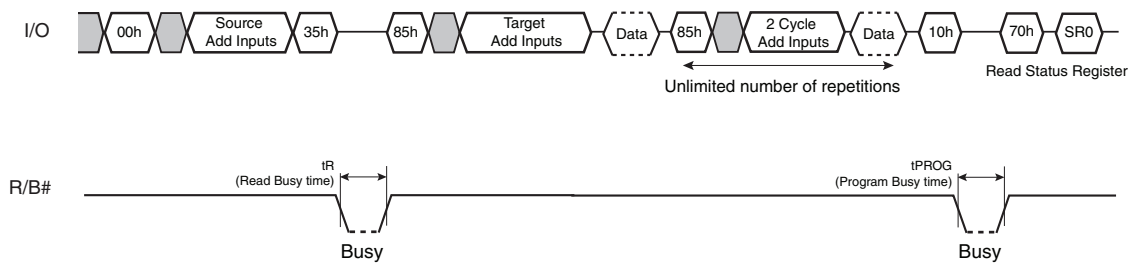
### 6.14 Copy Back Read with Optional Data Readout

Figure 6.14 Copy Back Read with Optional Data Readout



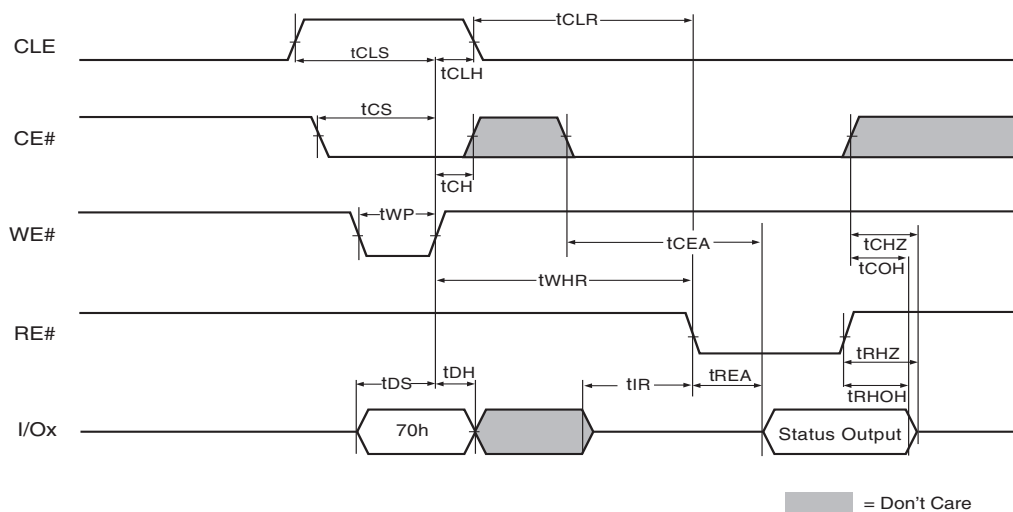
### 6.15 Copy Back Program Operation With Random Data Input

Figure 6.15 Copy Back Program with Random Data Input

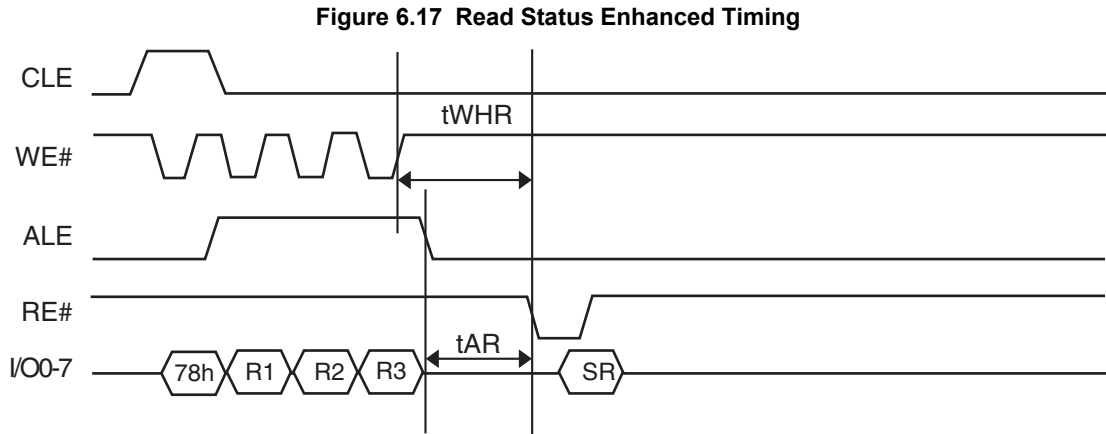


### 6.16 Read Status Register Timing

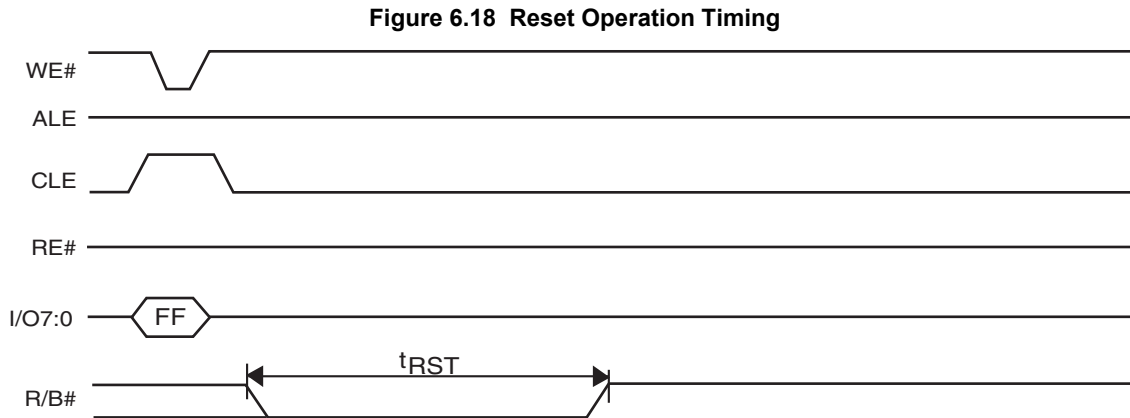
Figure 6.16 Status Read Cycle



### 6.17 Read Status Enhanced Timing



### 6.18 Reset Operation Timing



### 6.19 Read Cache

Figure 6.19 Read Cache Operation Timing

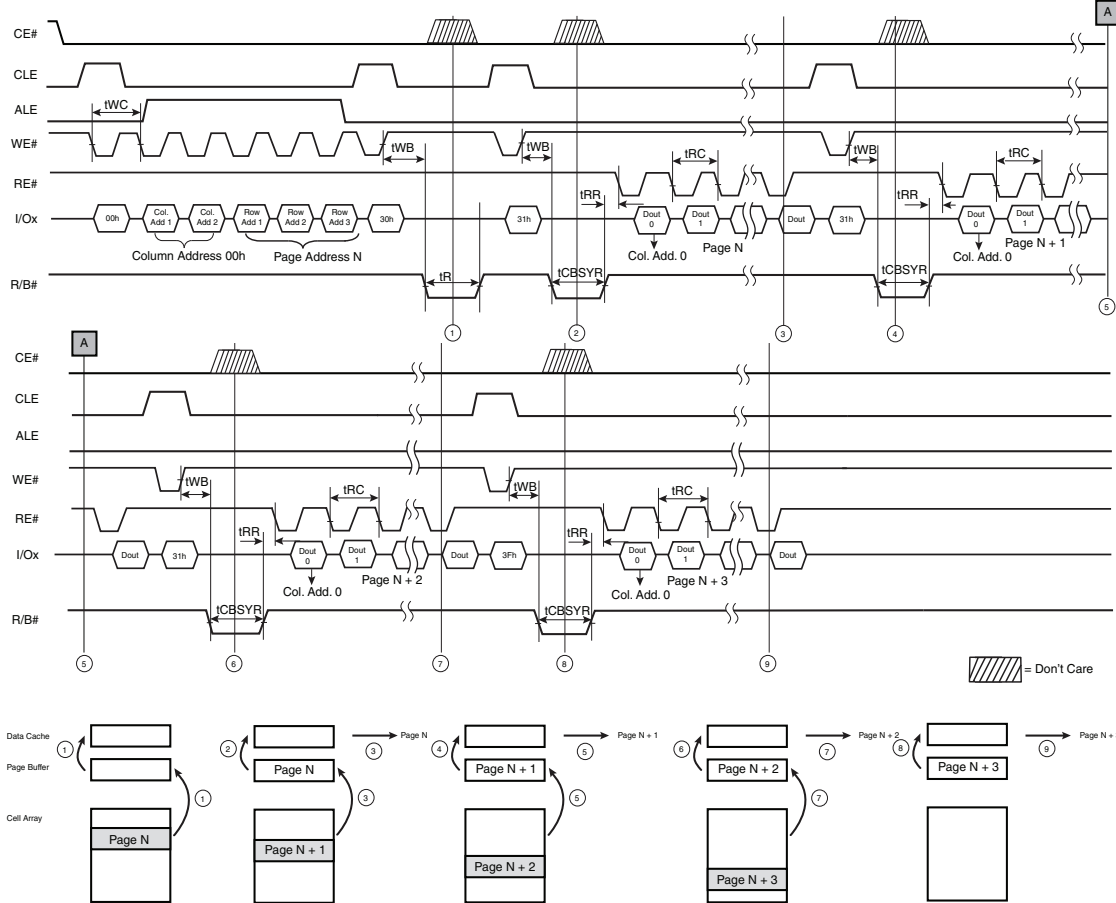
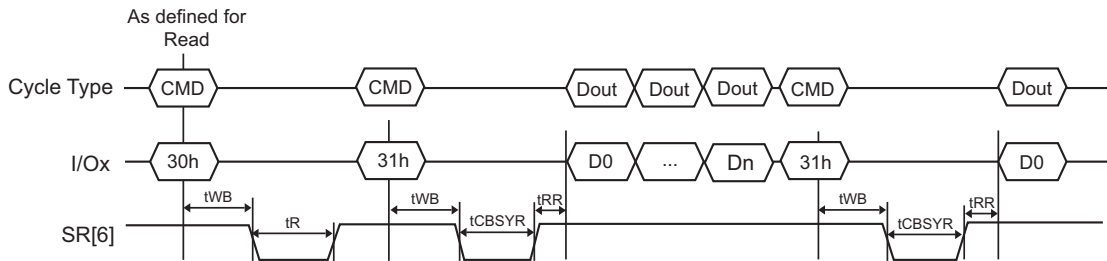
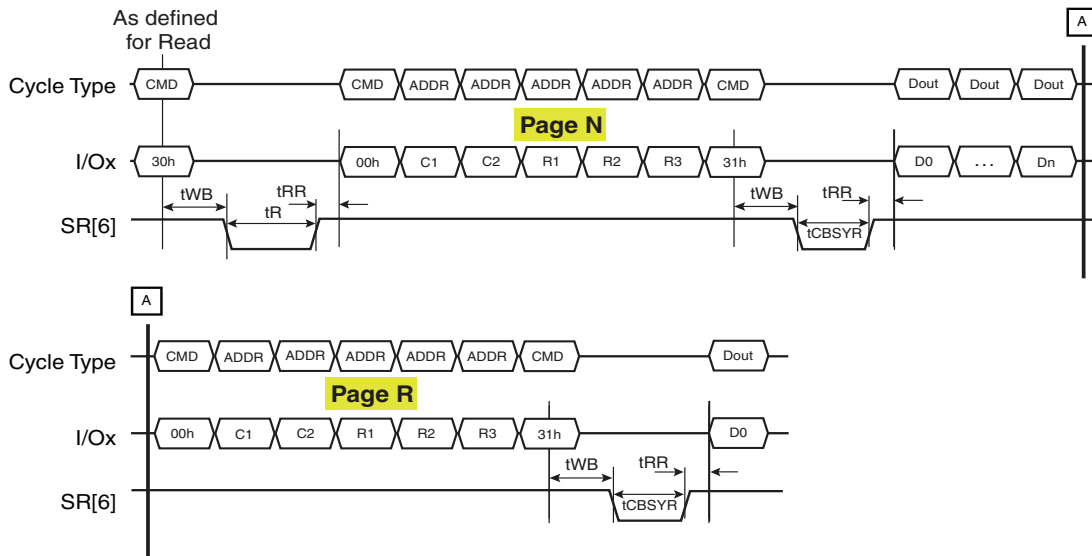


Figure 6.20 "Sequential" Read Cache Timing, Start (and Continuation) of Cache Operation

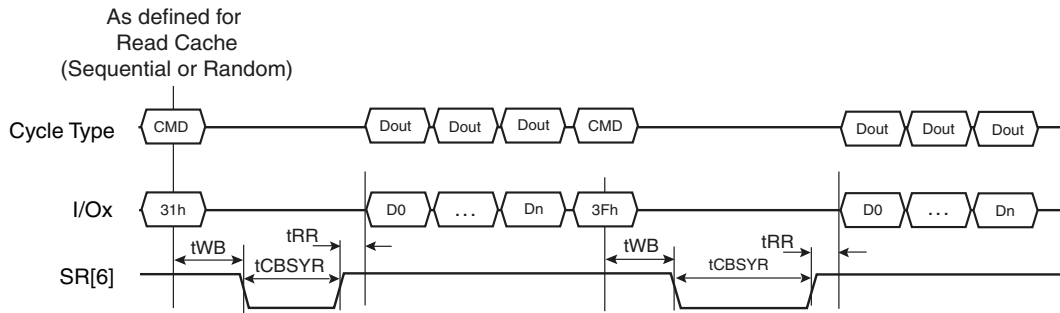




**Figure 6.21 “Random” Read Cache Timing, Start (and Continuation) of Cache Operation**

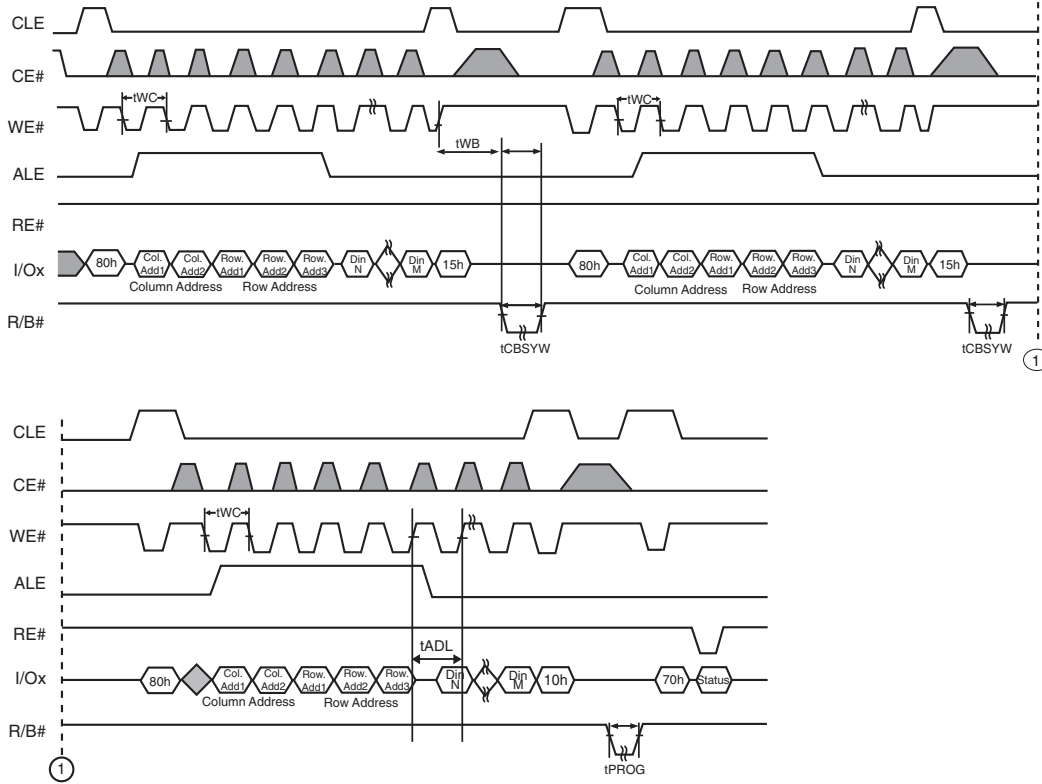


**Figure 6.22 Read Cache Timing, End Of Cache Operation**



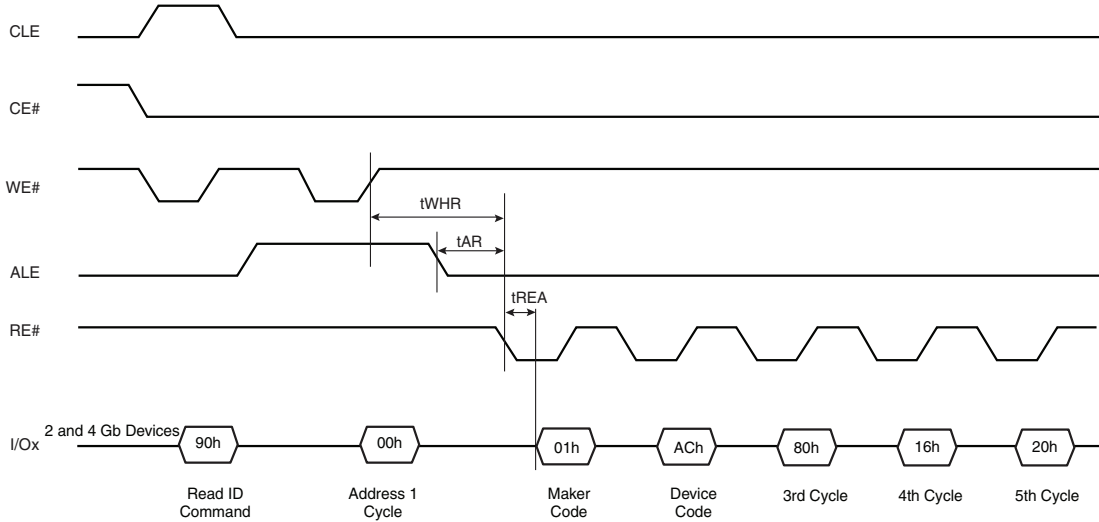
### 6.20 Cache Program

Figure 6.23 Cache Program



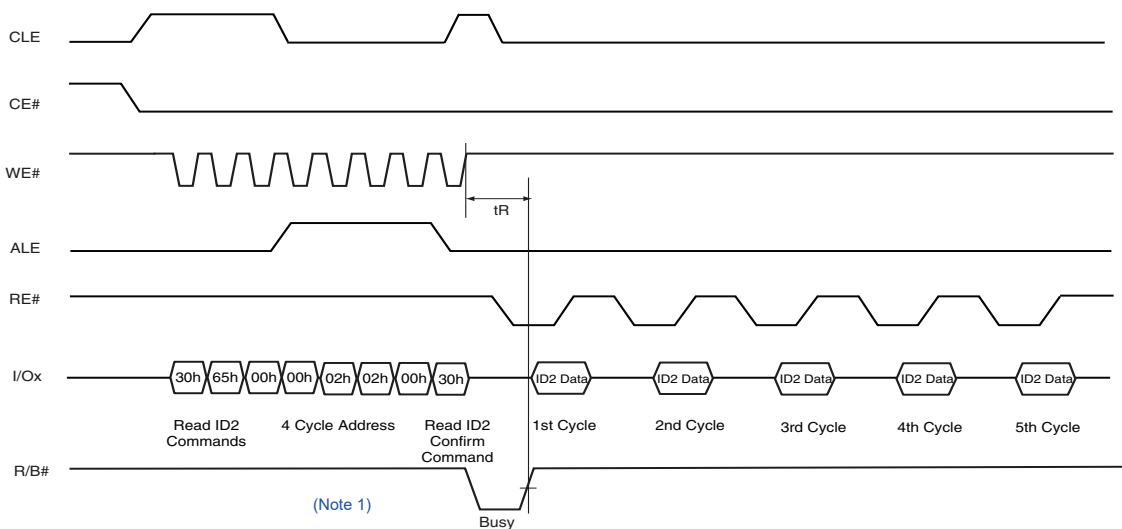
### 6.21 Read ID Operation Timing

Figure 6.24 Read ID Operation Timing



### 6.22 Read ID2 Operation Timing

Figure 6.25 Read ID2 Operation Timing

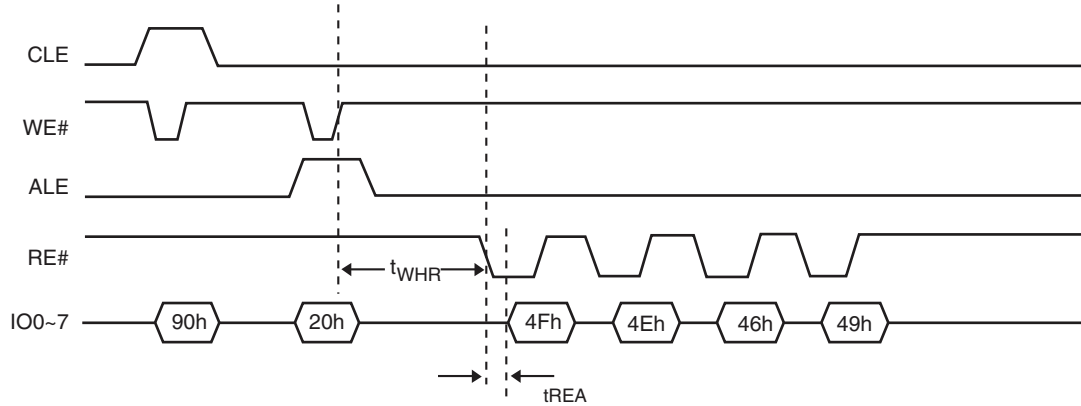


**Notes:**

1. For S34MS04G2, insert an additional address cycle of 00h.
2. If Status Register polling is used to determine completion of the Read ID2 operation, the Read Command (00h) must be issued before ID2 data can be read from the flash.

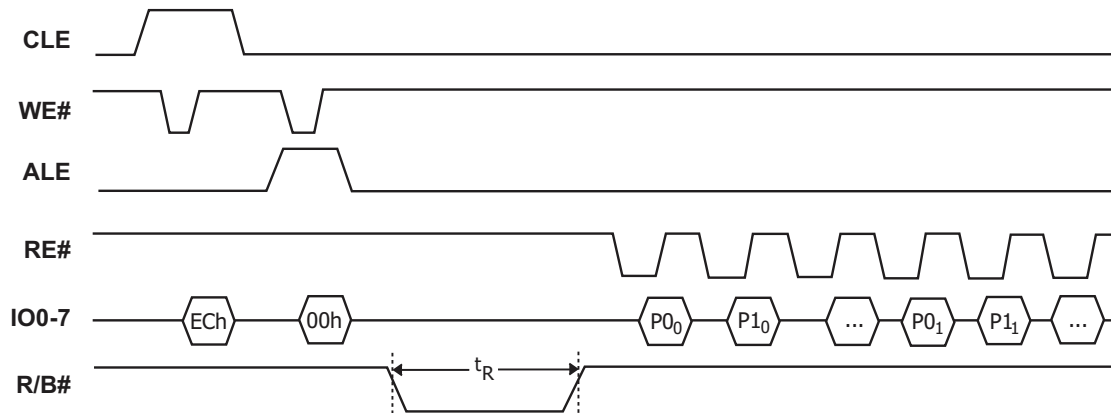
### 6.23 Read ONFI Signature Timing

Figure 6.26 ONFI Signature Timing



### 6.24 Read Parameter Page Timing

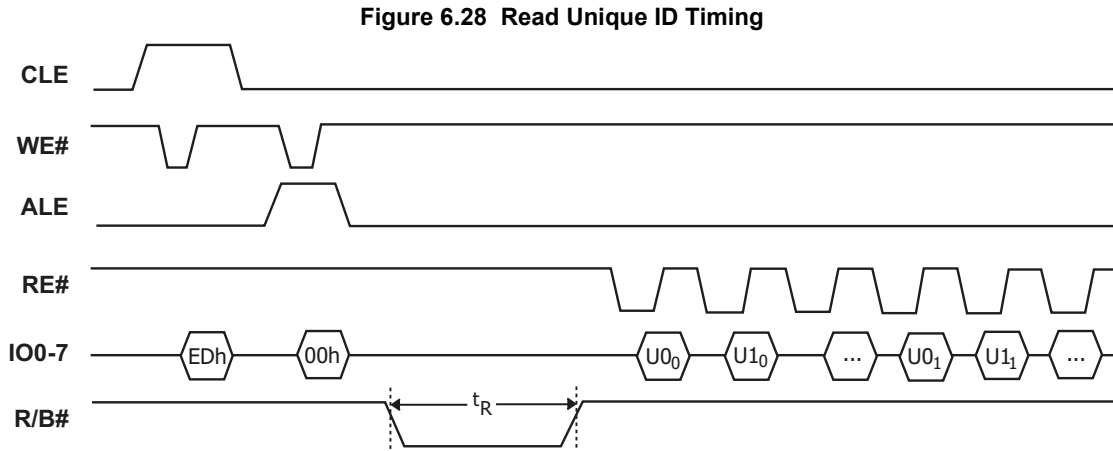
Figure 6.27 Read Parameter Page Timing



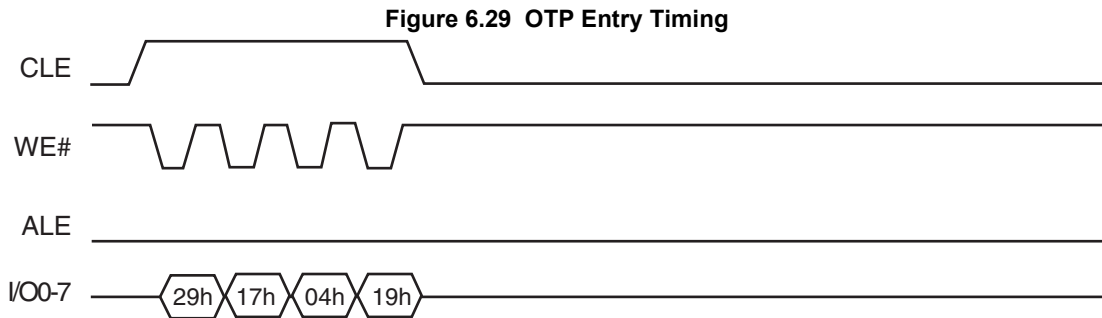
**Note:**

1. If Status Register polling is used to determine completion of the read operation, the Read Command (00h) must be issued before data can be read from the page buffer.

### 6.25 Read Unique ID Timing (Contact Factory)

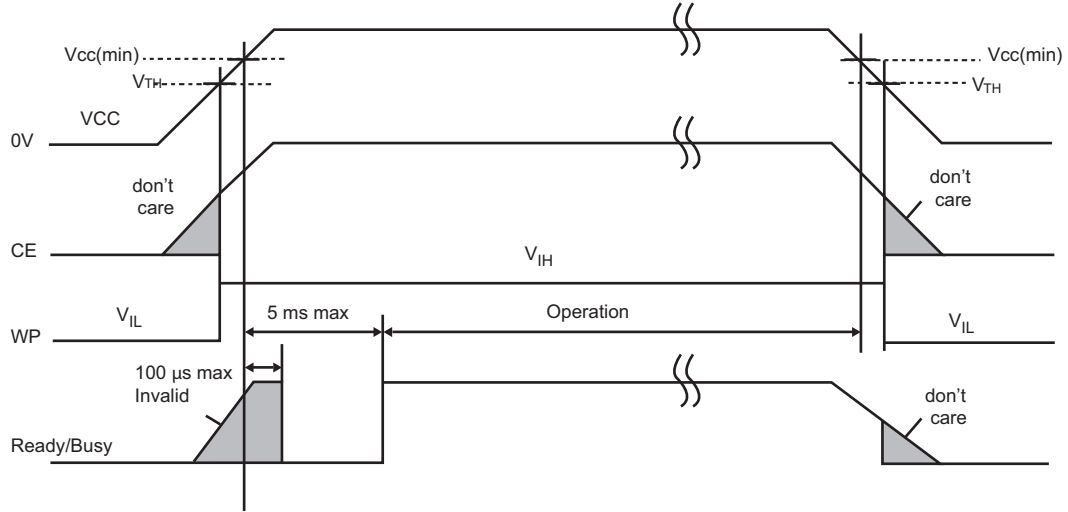


### 6.26 OTP Entry Timing



### 6.27 Power On and Data Protection Timing

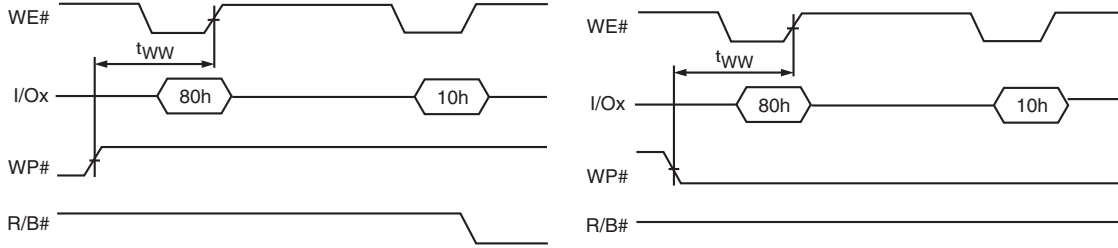
Figure 6.30 Power On and Data Protection Timing



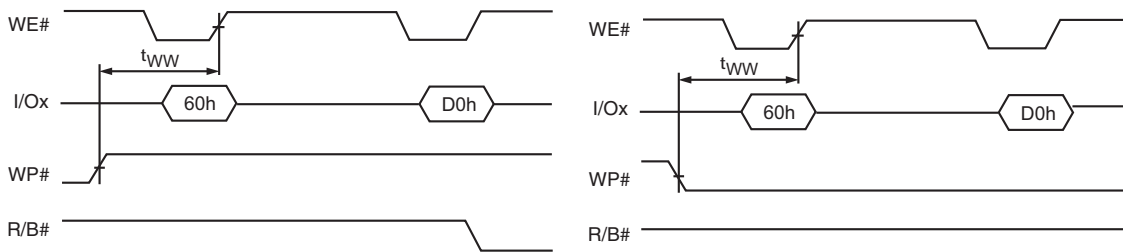
**Note:**  
1.  $V_{TH} = 1.2$  volts.

### 6.28 WP# Handling

**Figure 6.31 Program Enabling / Disabling Through WP# Handling**

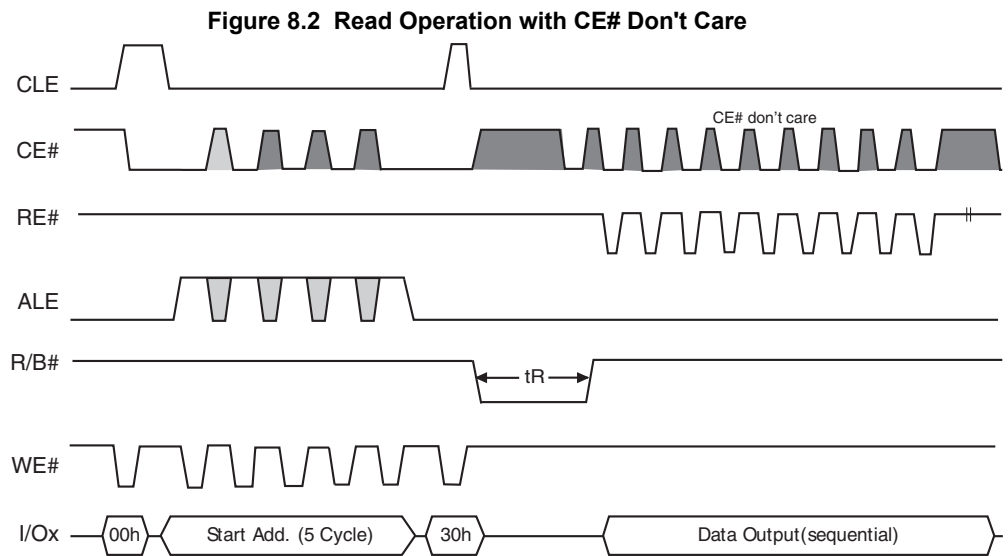
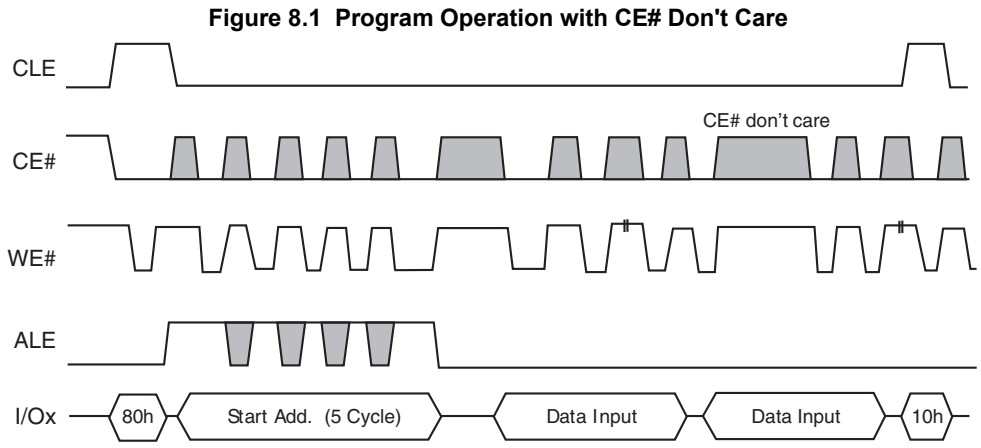


**Figure 6.32 Erase Enabling / Disabling Through WP# Handling**



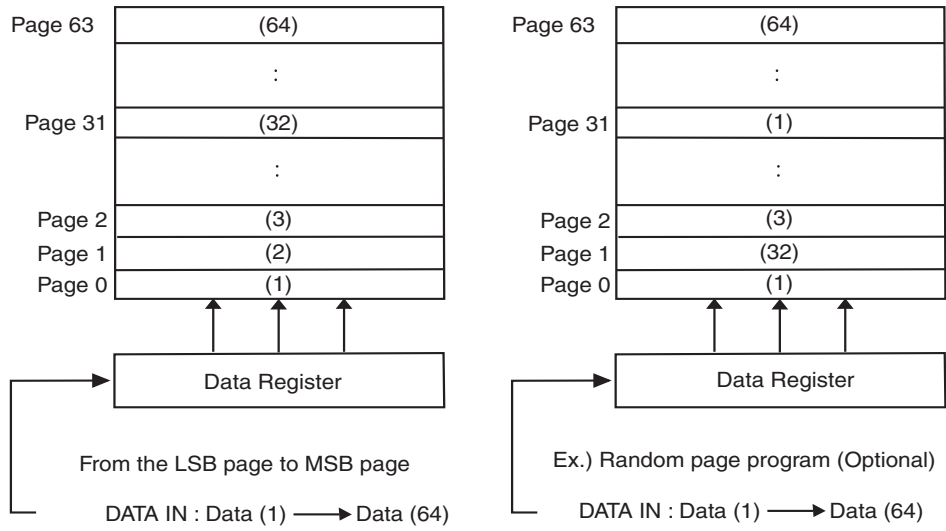
### 8. System Interface

To simplify system interface, CE# may be unasserted during data loading or sequential data reading as shown in [Figure 8.1](#). By operating in this way, it is possible to connect NAND flash to a microprocessor.





**Figure 8.3 Page Programming Within a Block**



## 9. Error Management

### 9.1 System Bad Block Replacement

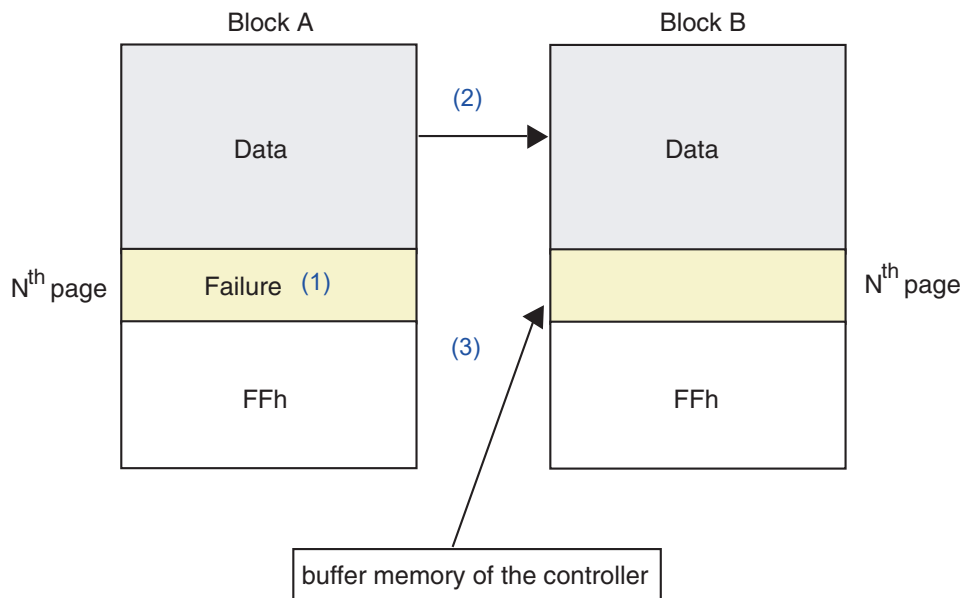
Over the lifetime of the device, additional Bad Blocks may develop. In this case, each bad block has to be replaced by copying any valid data to a new block. These additional Bad Blocks can be identified whenever a program or erase operation reports “Fail” in the Status Register.

The failure of a page program operation does not affect the data in other pages in the same block, thus the block can be replaced by re-programming the current data and copying the rest of the replaced block to an available valid block. Refer to [Table 9.1](#) and [Figure 9.1](#) for the recommended procedure to follow if an error occurs during an operation.

**Table 9.1 Block Failure**

Operation	Recommended Procedure
Erase	Block Replacement
Program	Block Replacement
Read	ECC (4 bit / 512+32 byte)

**Figure 9.1 Bad Block Replacement**



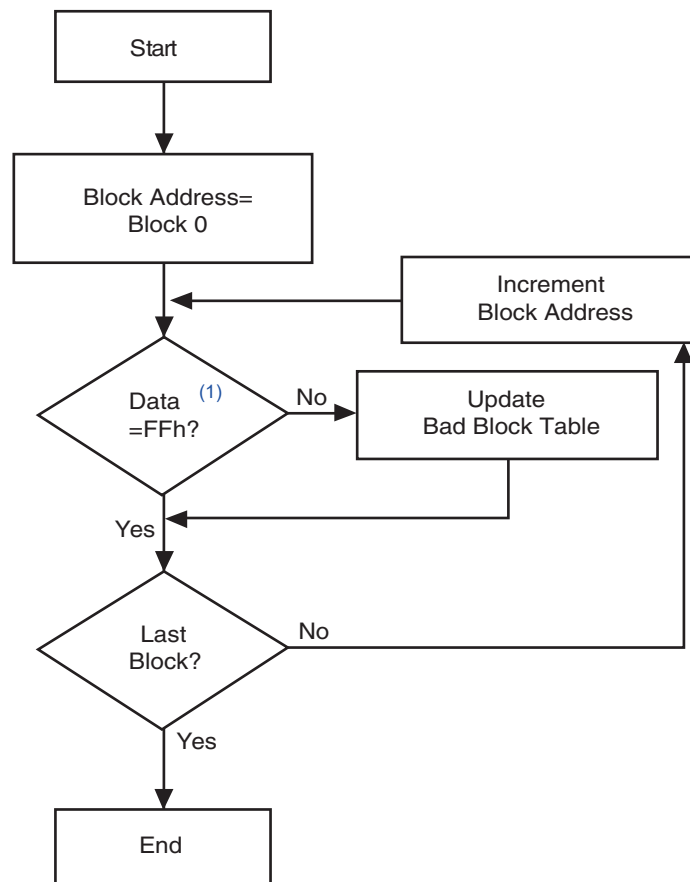
**Notes:**

1. An error occurs on the Nth page of Block A during a program operation.
2. Data in Block A is copied to the same location in Block B, which is a valid block.
3. The Nth page of block A, which is in controller buffer memory, is copied into the Nth page of Block B.
4. Bad block table should be updated to prevent from erasing or programming Block A.

### 9.2 Bad Block Management

Devices with Bad Blocks have the same quality level and the same AC and DC characteristics as devices where all the blocks are valid. A Bad Block does not affect the performance of valid blocks because it is isolated from the bit line and common source line by a select transistor. The devices are supplied with all the locations inside valid blocks erased (FFh). The Bad Block Information is written prior to shipping. Any block where the 1st byte in the spare area of the 1st or 2nd or last page does not contain FFh is a Bad Block. That is, if the first page has an FF value and should have been a non-FF value, then the non-FF value in the second page or the last page will indicate a bad block. The Bad Block Information must be read before any erase is attempted, as the Bad Block Information may be erased. For the system to be able to recognize the Bad Blocks based on the original information, it is recommended to create a Bad Block table following the flowchart shown in Figure 9.2. The host is responsible to detect and track bad blocks, both factory bad blocks and blocks that may go bad during operation. Once a block is found to be bad, data should not be written to that block. The 1st block, which is placed on 00h block address is guaranteed to be a valid block.

**Figure 9.2 Bad Block Management Flowchart**



**Note:**

1. Check for FFh at the 1st byte in the spare area of the 1st, 2nd, and last pages.

## 2Gbit LPDDR4X SDRAM

### 1. FEATURES

- VDD1 = 1.8V (1.7V to 1.95V)
- VDD2 = 1.1V (1.06 to 1.17)
- VDDQ = 0.6V (0.57 to 0.65)
- Programmable CA ODT and DQ ODT with VSSQ termination
- VOH compensated output driver
- Single data rate command and address entry
- Double data rate architecture for data Bus;
  - two data accesses per clock cycle
- Differential clock inputs (CK\_t, CK\_c)
- Bi-directional differential data strobe (DQS\_t, DQS\_c)
- DMI pin support for write data masking and DBI<sub>dc</sub> functionality
- Programmable RL (Read Latency) and WL (Write Latency)
- Burst length: 16 (default), 32 and On-the-fly
  - On the fly mode is enabled by MRS
- Auto refresh and self refresh supported
- All bank auto refresh and directed per bank auto refresh supported
- Auto TCSR (Temperature Compensated Self Refresh)
- PASR (Partial Array Self Refresh) by Bank Mask and Segment Mask
- Background ZQ Calibration

## 2. Functional Description

LPDDR4-SDRAM is a high-speed synchronous DRAM device internally configured as an 2-channel memory with 8-bank memory per each channel.

These devices contain the following number of bits per die:

2Gb has 2,147,483,648 bits

LPDDR4 devices use multi cycle of single data rate architecture on the Command/Address (CA) bus to reduce the number of input pins in the system. The 6-bit CA bus contains command, address and bank information. Each command uses two clock cycles, during which command information is transferred on positive edge of the corresponding clock.

These devices also use a double data rate architecture on the DQ pins to achieve high speed operation. The double data rate architecture is essentially an 16n prefetch architecture with an interface designed to transfer two data bits per DQ every clock cycle at the I/O pins. A single read or write access for the LPDDR4 SDRAM effectively consists of a single 16n-bit wide, one clock cycle data transfer at the internal DRAM core and sixteen corresponding n-bit wide, one-half-clock-cycle data transfers at the I/O pins.

Read and write accesses to the LPDDR4 SDRAMs are burst oriented; accesses start at a selected location and continue for a programmed number of locations in a programmed sequence. Accesses begin with the registration of an Activate command, which is then followed by a Read or Write command. The address and BA bits registered coincident with the Activate command are used to select the row and the bank to be accessed. The address bits registered coincident with the Read or Write command are used to select the bank and the starting column location for the burst access.

Prior to normal operation, the LPDDR4 SDRAM must be initialized. The following section provides detailed information covering device initialization, register definition, command description and device operation

### 2.1. LPDDR4 SDRAM Addressing

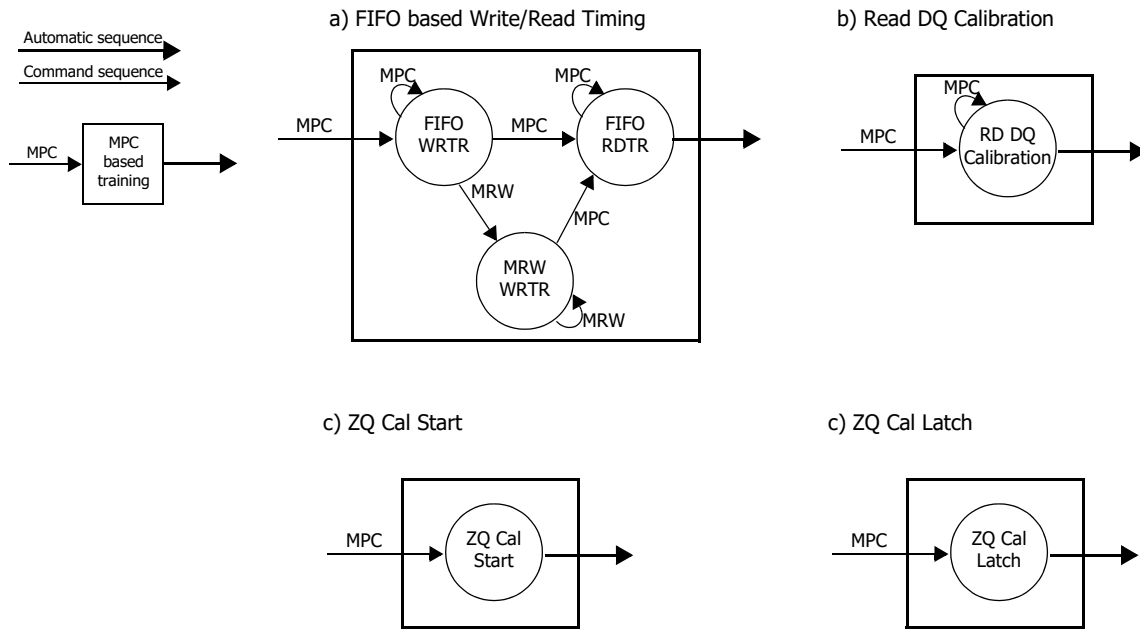
Memory Density (per Die)	2Gb	4Gb
Memory Density (per channel)	2Gb	2Gb
Configuration	16 Mb x 16 DQ x 8 banks x 1 channels	16 Mb x 16 DQ x 8 banks x 2 channels
Number of Channels per die	1	2
Number of Banks per Channel	8	8

Memory Density (per Die)		2Gb	4Gb
Array Pre-fetch (bits, per channel)		256	256
Number of Rows per Channel		16,384	16,384
Number of Columns (fetch boundaries)		64	64
Page Size (Bytes)		2048	2048
Channel Density (Bits per channel)		2,147,483,648	2,147,483,648
Total Density (Bits per die)		2,147,483,648	4,294,967,296
Bank Address		BA0 - BA2	BA0 - BA2
x16	Row Addresses	R0 - R13	R0 - R13
	Column Addresses	C0 - C9	C0 - C9
Burst Starting Address Boundary		64-bit	64-bit

1. The lower two column addresses (C0-C1) are assumed to be "zero" and are not transmitted on the CA bus.
2. Row and Column address values on the CA bus that are not used for a particular density are "don't care."
3. For non-binary memory densities, only half of the row address space is valid. When the MSB address bit is "HIGH", then the MSB-1 address bit must be "LOW".



**Figure - Simplified Bus Interface State Diagram**



**Notes:**

1. From the Self-Refresh state the device can enter Power-Down, MRR, MRW, or MPC states. See the section on Self-Refresh for more information.
2. In IDLE state, all banks are pre-charged.
3. In the case of a MRW command to enter a training mode, the state machine will not automatically return to the IDLE state at the conclusion of training. See the applicable training section for more information.
4. In the case of a MPC command to enter a training mode, the state machine may not automatically return to the IDLE state at the conclusion of training. See the applicable training section for more information.
5. This simplified State Diagram is intended to provide an overview of the possible state transitions and the commands to control them. In particular, situations involving more than one bank, the enabling or disabling of on-die termination, and some other events are not captured in full detail.
6. States that have an "automatic return" and can be accessed from more than one prior state (Ex. MRW from either Idle or Active states) will return to the state from when they were initiated (Ex. MRW from Idle will return to Idle).
7. The RESET\_n pin can be asserted from any state, and will cause the SDRAM to go to the Reset State. The diagram shows RESET applied from the Power-On as an example, but the Diagram should not be construed as a restriction on RESET\_n.



### 2.4.1. Power-up and Initialization

For power-up and reset initialization, in order to prevent DRAM from functioning improperly, default values of the following MR settings are defined as following table.

**Table - MRS defaults settings**

Item	MRS	Default setting	Description
FSP-OP/WR	MR13 OP[7:6]	00B	FS-OP/WR[0] are enabled
WLS	MR2 OP[6]	0B	Write Latency Set 0 is selected
WL	MR2 OP[5:3]	000B	WL = 4
RL	MR2 OP[2:0]	000B	RL = 6, nRTP = 8
nWR	MR1 OP[6:4]	000B	nWR = 6
DBI-WR/RD	MR3 OP[7:6]	00B	Write & Read DBI are disabled
CA ODT	MR11 OP[6:4]	000B	CA ODT is disabled
DQ ODT	MR11 OP[2:0]	000B	DQ ODT is disabled
Vref(ca) Setting	MR12 OP[6]	1B	Vref(ca) Range[1] enabled
Vref(ca) value	MR12 OP[5:0]	011101B	Range1: 50.4% of VDDQ
Vref(DQ) Setting	MR14 OP[6]	1B	Vref(DQ) Range[1] enabled
Vref(DQ) Value	MR14 OP[5:0]	011101B	Range1: 50.4% of VDDQ

#### 2.4.1.1. Voltage Ramp and Device Initialization

The following sequence shall be used to power up the LPDDR4 device. Unless specified otherwise, these steps are mandatory. Note that the power-up sequence of all channels must proceed simultaneously.

1. While applying power (after Ta), RESET\_n is recommended to be LOW ( $\leq 0.2 \times VDD2$ ) and all inputs must be between VILmin and VIHmax. The device outputs remain at High-Z while RESET\_n is held LOW. Power supply voltage ramp requirements are provided in Table - Voltage Ramp Conditions. VDD1 must ramp at the same time or earlier than VDD2. VDD2 must ramp at the same time or earlier than VDDQ.

**Table - Voltage Ramp Conditions**

After...	Applicable Conditions
Ta is reached	VDD1 must be greater than VDD2
	VDD2 must be greater than VDDQ - 200mV

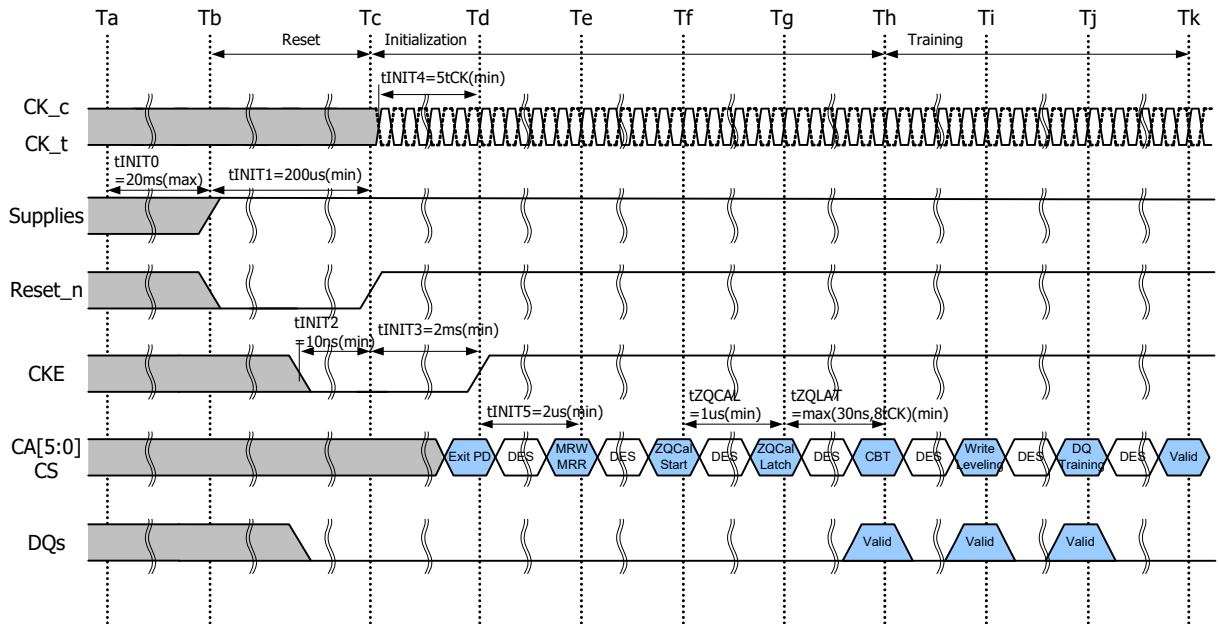
Note:

1. Ta is the point when any power supply first reaches 300mV.
2. Voltage ramp conditions in above table apply between Ta and power-off (controlled or uncontrolled).
3. Tb is the point at which all supply and reference voltages are within their defined ranges.
4. Power ramp duration tINIT0 (Tb-Ta) must not exceed 20ms.
5. The voltage difference between any of VSS and VSSQ pins must not exceed 100mV.

2. Following the completion of the voltage ramp (Tb), RESET\_n must be maintained LOW. DQ, DMI, DQS\_t and DQS\_c voltage levels must be between Vssq and Vddq during voltage ramp to avoid latch-up. CKE, CK\_t, CK\_c, CS\_n and CA input levels must be between Vss and VDD2 during voltage ramp to avoid latch-up.

3. Beginning at Tb, RESET\_n must remain LOW for at least tINIT1(Tc), after which RESET\_n can be de-asserted to HIGH(Tc). At least 10ns before CKE de-assertion, CKE is required to be set LOW. All other input signals are "Don't Care".

**Figure - Power Ramp and Initialization Sequence**



**Note**

1. Training is optional and may be done at the system architect's discretion. The training sequence after ZQ\_CAL Latch (Th, Sequence 7~9) in the above figure, is simplified recommendation and actual training sequence may vary depending on systems.
4. After RESET\_n is de-asserted (Tc), wait at least tINIT3 before activating CKE. Clock (CK\_t, CK\_c) is required to be started and stabilized for tINIT4 before CKE goes active (Td). CS is required to be maintained LOW when controller activates CKE.
5. After setting CKE high, wait minimum of tINIT5 to issue any MRR or MRW commands (Te). For both MRR and MRW commands, the clock frequency must be within the range defined for tCKb. Some AC parameters (for example, tDQSQCK) could have relaxed timings (such as tDQSQCKb) before the system is appropriately configured.
6. After completing all MRW commands to set the Pull-up, Pull-down and Rx termination values, the DRAM controller can issue ZQCAL Start command to the memory (Tf). This command is used to calibrate VOH level and output impedance over process, voltage and temperature. In systems where more than one LPDDR4 DRAM devices share one external ZQ resistor, the controller must not overlap the ZQ calibration sequence of each LPDDR4 device. ZQ calibration sequence is completed after tZQCAL (Tg) and the ZQCAL Latch command must be issued to update the DQ drivers and DQ+CA ODT to the calibrated values.
7. After tZQLAT is satisfied (Th) the command bus (internal VREF(ca), CS, and CA) should be trained for high-speed operation by issuing an MRW command (Command Bus Training Mode). This command is used to calibrate the device's internal VREF and align CS/CA with CK for high-speed operation. The LPDDR4 device will power-up with receivers configured for low-speed operations, and VREF(ca) set to a default factory setting. Normal device operation at clock speeds higher than tCKb may not be possible until command bus training has been completed. The command bus training MRW command uses the CA bus as inputs for the calibration data stream, and outputs the results asynchronously on the DQ bus. See command bus training in the MRW section for information on how to enter/exit the training mode.

8. After command bus training, DRAM controller must perform write leveling. Write leveling mode is enabled when MR2 OP[7] is high(Ti). See write leveling section for detailed description of write leveling entry and exit sequence. In write leveling mode, the DRAM controller adjusts write DQS\_t/\_c timing to the point where the LPDDR4 device recognizes the start of write DQ data burst with desired write latency.

9. After write leveling, the DQ Bus (internal VREF(dq), DQS, and DQ) should be trained for high-speed operation using the MPC training commands and by issuing MRW commands to adjust VREF(dq)(Tj). The LPDDR4 device will power-up with receivers configured for low-speed operations and VREF(dq) set to a default factory setting. Normal device operation at clock speeds higher than tCKb should not be attempted until DQ Bus training has been completed. The MPC Read Calibration command is used together with MPC FIFO Write/Read commands to train DQ bus without disturbing the memory array contents. See DQ Bus Training section for detailed DQ Bus Training sequence.

10. At Tk the LPDDR4 device is ready for normal operation, and is ready to accept any valid command. Any more registers that have not previously been set up for normal operation should be written at this time.

**Table - Initialization Timing Parameters**

Parameter	Value		Unit	Comment
	Min	Max		
tINIT0		20	ms	Maximum Voltage Ramp Time
tINIT1	200		us	Minimum RESET_n LOW time after completion of voltage ramp
tINIT2	10		ns	Minimum CKE LOW time before RESET_n goes HIGH
tINIT3	2		ms	Minimum CKE LOW time after RESET_n goes HIGH
tINIT4	5		tCK	Minimum stable clock before first CKE HIGH
tINIT5	2		us	Minimum idle time before first MRW/MRR command
tZQCAL	1		us	ZQ Calibration time
tZQLAT	Max(30ns,8tCK)		ns	ZQCAL latch quite time
tCKb	Note 1, 2	Note 1, 2	ns	Clock cycle time during boot

Notes

1. Min tCKb guaranteed by DRAM test is 18ns.
2. The system may boot at a higher frequency than dictated by min tCKb. The higher boot frequency is system dependent

### 2.4.1.2. Reset Initialization with Stable Power

The following sequence is required for RESET at no power interruption initialization.

1. Assert RESET\_n below 0.2 x VDD2 anytime when reset is needed. RESET\_n needs to be maintained for minimum tPW\_RESET. CKE must be pulled LOW at least 10 ns before de-asserting RESET\_n.

2. Repeat steps 4 to 10 in "Voltage Ramp and Device Initialization" section.

**Table - Reset Timing Parameter**

Parameter	Value		Unit	Comment
	Min	Max		
tPW_RESET	100	-	ns	Minimum RESET_n low time for Reset Initialization with stable power

### 2.4.2. Power-off Sequence

#### 2.4.2.1. Controlled Power-off

The following procedure is required to power off the device.

While powering off, CKE must be held LOW ( $\leq 0.2 \times VDD2$ ) and all other inputs must be between  $VIL_{min}$  and  $VIH_{max}$ . The device outputs remain at High-Z while CKE is held LOW. DQ, DMI, DQS\_t and DQS\_c voltage levels must be between VSSQ and VDDQ during voltage ramp to avoid latch-up. RESET\_n, CK\_t, CK\_c, CS and CA input levels must be between VSS and VDD2 during voltage ramp to avoid latch-up.

Tx is the point where any power supply drops below the minimum value specified.

Tz is the point where all power supplies are below 300mV. After TZ, the device is powered off.

**Table - Power Supply Conditions for Power-off**

Between...	Applicable Conditions
TX and TZ	VDD1 must be greater than VDD2
	VDD2 must be greater than VDDQ - 200mV

Note: The voltage difference between any of VSS, VSSQ pins must not exceed 100mV

#### 2.4.2.2. Uncontrolled Power-off Sequence

When an uncontrolled power-off occurs, the following conditions must be met:

At Tx, when the power supply drops below the minimum values specified, all power supplies must be turned off and all power supply current capacity must be at zero, except any static charge remaining in the system.

After Tz (the point at which all power supplies first reach 300mV), the device must power off. During this period the relative voltage between power supplies is uncontrolled. VDD1 and VDD2 must decrease with a slope lower than  $0.5V/\mu s$  between Tx and Tz.

An uncontrolled power-off sequence can occur a maximum of 400 times over the life of the device.

**Table - Timing Parameters for Power-off**

Symbol	Value		Unit	Comment
	Min	Max		
tPOFF		2	s	Maximum Power-off ramp time

## 2.5. Mode Register Definition

Table below shows the mode registers for LPDDR4 SDRAM. Each register is denoted as "R" if it can be read but not written, "W" if it can be written but not read, and "R/W" if it can be read and written. A Mode Register Read command is used to read a mode register. A Mode Register Write command is used to write a mode register.

**Table. Mode Register Assignment**

MR#	MA <5:0>	Function	Access	OP7	OP6	OP5	OP4	OP3	OP2	OP1	OP0	Link	
0	00H	Device Information	R	Reserved	RFU		RZQI		RFU	Latency Mode	Refresh Mode	MR0	
1	01H	Device Feature 1	W	RPST	nWR (for AP)			RD-PRE	WR-PRE	BL		MR1	
2	02H	Device Feature 2	W	WR Lev	WLS	WL			RL			MR2	
3	03H	IO Configuration 1	W	DBI-WR	DBI-RD	PDDS			PPRP	WR-PST	PU-CAL	MR3	
4	04H	Refresh Rate	R/W	TUF	Thermal Offset		PPRE	SR Abort	Refresh Rate			MR4	
5	05H	Basic Configuration 1	R	LPDDR4 Manufacturer ID								MR5	
6	06H	Basic Configuration 2	R	Revision ID-1								MR6	
7	07H	Basic Configuration 3	R	Revision ID-2								MR7	
8	08H	Basic Configuration 4	R	IO Width			Density			Type			MR8
9	09H	Test Mode	W	Vendor Specific Test Mode								MR9	
10	0AH	ZQ Reset	W	RFU								ZQ Reset	MR10
11	0BH	ODT Feature	W	DQ ODT-nt	CA ODT			DQ ODT-nt	DQ ODT			MR11	
12	0CH	VREF(ca) R0	R/W	CBT Mode	VR-CA	VREF(ca)					MR12		
13	0DH	Functional options	W	FSP-OP	FSP-WR	DMD	RRO	VRCG	VRO	RPT	CBT	MR13	
14	0EH	VREF(dq)	R/W	RFU	VR(dq)	VREF(dq)					MR14		
15	0FH	Invert Register 0	W	Lower Byte Invert for DQ Calibration								MR15	
16	10H	PASR Bank	W	PASR Bank Mask								MR16	
17	11H	PASR Segment	W	PASR Segment Mask								MR17	
18	12H	DQS Oscillator 1	R	DQS Oscillator Count - LSB								MR18	
19	13H	DQS Oscillator 2	R	DQS Oscillator Count - MSB								MR19	
20	14H	Invert Register 1	W	Upper Byte Invert for DQ Calibration								MR20	
21	15H	Vendor Specific	N/A	RFU								MR21	
22	16H	SOC ODT Feature	W	ODTD for x8_2ch (Byte) mode	ODTD-CA	ODTE-CS	ODTE-CK	SOC ODT				MR22	
23	17H	DQS Oscillator Run Time	W	DQS Oscillator Interval Timer Run Time Setting								MR23	
24	18H	TRR	R/W	TRR	TRR Bank Address			U-MAC	MAC Value			MR24	
25	19H	PPR Resource	R	Post Package Repair Resources								MR25	
26	1AH	RFU	N/A	Reserved for Future Use								MR26	
27	1BH	RFU	N/A	Reserved for Future Use								MR27	
28	1CH	RFU	N/A	Reserved for Future Use								MR28	
29	1DH	RFU	N/A	Reserved for Future Use								MR29	
30	1EH	RFU	N/A	Reserved for Future Use								MR30	
31	1FH	RFU	N/A	Reserved for Future Use								MR31	
32	20H	DQ Calibration - Pattern A	W	See "DQ Calibration" section								MR32	
33:36	21H:24H	DNU	N/A	Do Not Use									
37	25H	TRR	R/W	RFU					VDDQ Level			MR37	
38:39	26H:27H	DNU	N/A	Do Not Use									
40	28H	DQ Calibration - Pattern B	W	See "DQ Calibration" section								MR40	
41:47	29H:2FH	DNU	N/A	Do Not Use									
48:63	30H:3FH	RFU	N/A	Reserved for Future Use									

1. RFU bits should be set to '0' during mode register writes

2. RFU bits should be read as '0' during mode register reads
3. All mode registers that are specified as RFU or Write-only shall return undefined data when read and DQS\_t/DQS\_c shall be toggled
4. All mode registers that are specified as RFU shall not be written
5. See vendor device datasheet for details on vendor-specific mode registers
6. Writes to Read-only registers shall have no effect on the functionality of the device

### 2.5.1. MR0 Register Information (MA[5:0] = 00H)

OP[7]	OP[6]	OP[5]	OP[4]	OP[3]	OP[2]	OP[1]	OP[0]
Reserved	RFU		RZQI		RFU	Latency Mode	Refresh Mode

Function	Register Type	Operand	Data	Notes
Refresh Mode	Read-only	OP[0]	0B: Both legacy & modified refresh mode supported 1B: Only modified refresh mode supported	
Latency Mode		OP[1]	0B: Device supports normal latency 1B: Device supports byte mode latency	6,7
RZQI (Built-in Self-Test for RZQ)		OP[4:3]	00B: RZQ Self-Test Not Supported 01B: ZQ pin may connect to VSS or float 10B: ZQ-pin may short to VDDQ 11B: ZQ-pin Self-Test Completed, no error condition detected (ZQ-pin may not connect to VDD2 or float, nor short to VSS)	1,2,3,4

Notes:

1. RZQI MR value, if supported, will be valid after the following sequence:
  - a. Completion of MPC ZQCAL Start command to either channel.
  - b. Completion of MPC ZQCAL Latch command to either channel then tZQLAT is satisfied. RZQI value will be lost after Reset.
2. If the ZQ-pin is connected to VSSQ to set default calibration, OP[4:3] shall be set to 01B. If the ZQ-pin is not connected to VSSQ, either OP[4:3] = 01B or OP[4:3] = 10B might indicate might indicate a ZQ-pin assembly error. It is recommended that the assembly error is corrected.
3. In the case of possible assembly error, the LPDDR4-SDRAM device will default to factory trim settings for RON, and will ignore ZQ Calibration commands. In either case, the device may not function as intended.
4. If ZQ Self-Test returns OP[4:3] = 11B, the device has detected a resistor connected to the ZQ-pin. However, this result cannot be used to validate the ZQ resistor value or that the ZQ resistor tolerance meets the specified limits (i.e. 240Ω ± 1%).
5. CATR functionality may not provide right information whether CA termination is turned on or not. However, CA termination is required to be decided with the combination of MR22 OP[5] and MR11 OP[6:4] which shows CA ODT values. It is recommended for user to have CATR information with the combination ODT\_PAD and MR11 OP[6:4]. MR0 OP[7] indicate 1'B only when MR22 OP[5] is high and MR11 OP[6:4] is not 000'b.
6. For the byte mode LPDDR4 SDRAM device, longer latency is required. The LPDDR4 SDRAM device will set MR0 OP[1]=1 to indicate which latencies are supported. See section for byte-mode latency for the details.
7. Devices not intended to be combined with byte mode devices are not required to support byte mode latency.

### 2.5.2. MR1 Register Information (MA[5:0] = 01H)

OP[7]	OP[6]	OP[5]	OP[4]	OP[3]	OP[2]	OP[1]	OP[0]
RPST	nWR (for AP)			RD-PRE	WR-PRE	BL	

Function	Register Type	Operand	Data	Notes
BL (Burst Length)	Write-only	OP[1:0]	00B: BL=16 Sequential (default) 01B: BL=32 Sequential 10B: BL=16 or 32 Sequential (on-the-fly) All Others: Reserved	1,5,6
WR-PRE (WR Pre-amble Length)		OP[2]	0B: Reserved 1B: WR Pre-amble = 2nCK (default)	5,6
RD-PRE (RD Pre-amble Type)		OP[3]	0B: RD Pre-amble = Static (default) 1B: RD Pre-amble = Toggle	3,5,6
nWR (Write-Recovery for Auto Precharge commands)		OP[6:4]	000B: nWR = 6 (default) 001B: nWR = 10 010B: nWR = 16 011B: nWR = 20 100B: nWR = 24 101B: nWR = 30 110B: nWR = 34 111B: nWR = 40	2,5,6
RPST (RD Post-amble Length)		OP[7]	0B: RD Post-amble = 0.5*tCK (default) 1B: RD Post-amble = 1.5*tCK	4,5,6

1. Burst length on-the-fly can be set to either BL=16 or BL=32 by setting the "BL" bit in the command operands. See the Command Truth Table.
2. The programmed value of nWR is the number of clock cycles the LPDDR4-SDRAM device uses to determine the starting point of an internal Pre-charge operation after a Write burst with AP (auto-pre-charge) enabled. See Table, "Frequency Ranges for RL, WL, and nWR Settings" later in this section
3. For Read operations this bit must be set to select between a "toggling" pre-amble and a "Non-toggling" pre-amble. See the pre-amble section for a drawing of each type of pre-amble.
4. OP[7] provides an optional READ post-amble with an additional rising and falling edge of DQS<sub>t</sub>. The optional postamble cycle is provided for the benefit of certain memory controllers.
5. There are two physical registers assigned to each bit of this MR parameter, designated set point 0 and set point 1. Only the registers for the set point determined by the state of the FSP-WR bit (MR13 OP[6]) will be written to with an MRW command to this MR address.
6. There are two physical registers assigned to each bit of this MR parameter, designated set point 0 and set point 1. The device will operate only according to the values stored in the registers for the active set point, i.e., the set point determined by the state of the FSP-OP bit (MR13 OP[7]). The values in the registers for the inactive set point will be ignored by the device, and may be changed without affecting device operation.





### 2.5.3. MR2 Register Information (MA[5:0] = 02H)

OP[7]	OP[6]	OP[5]	OP[4]	OP[3]	OP[2]	OP[1]	OP[0]
WR Lev	WLS	WL			RL		

Standard LPDDR4

Function	Register Type	Operand	Data	Notes
RL (Read latency)	Write only	OP[2:0]	<b>DBI Disable (MR3 OP[6]=0B)</b> 000B: RL= 6 & nRTP = 8 (Default) 001B: RL= 10 & nRTP = 8 010B: RL= 14 & nRTP = 8 011B: RL= 20 & nRTP = 8 100B: RL= 24 & nRTP = 10 101B: RL= 28 & nRTP = 12 110B: RL= 32 & nRTP = 14 111B: RL= 36 & nRTP = 16 <b>DBI Enable (MR3 OP[6]=1B)</b> 000B: RL= 6 & nRTP = 8 001B: RL= 12 & nRTP = 8 010B: RL= 16 & nRTP = 8 011B: RL= 22 & nRTP = 8 100B: RL= 28 & nRTP = 10 101B: RL= 32 & nRTP = 12 110B: RL= 36 & nRTP = 14 111B: RL= 40 & nRTP = 16	1,3,4
WL (Write latency)		OP[5:3]	<b>Set "A" (MR2 OP[6]=0B)</b> 000B: WL=4 (Default) 001B: WL=6 010B: WL=8 011B: WL=10 100B: WL=12 101B: WL=14 110B: WL=16 111B: WL=18 <b>Set "B" (MR2 OP[6]=1B)</b> 000B: WL=4 001B: WL=8 010B: WL=12 011B: WL=18 100B: WL=22 101B: WL=26 110B: WL=30 111B: WL=34	1,3,4
WLS (Write latency set)		OP[6]	0B: WL Set "A" (default) 1B: WL Set "B"	1,3,4
WR Lev (Write Leveling)		OP[7]	0B: Disabled (default) 1B: Enabled	2

1. See Latency Code Frequency Table for allowable frequency ranges for RL/WL/nWR/nRTP.
2. After a MRW to set the Write Leveling Enable bit (OP[7]=1B), the LPDDR4-SDRAM device remains in the MRW state until another MRW command clears the bit (OP[7]=0B). No other commands are allowed until the Write Leveling Enable bit is cleared.
3. There are two physical registers assigned to each bit of this MR operand, designated set point 0 and set point 1. Only the registers for the set point determined by the state of the FSP-WR bit (MR13 OP[6]) will be written to with an MRW command to this MR address.
4. There are two physical registers assigned to each bit of this MR operand, designated set point 0 and set point 1. The device will operate only according to the values stored in the registers for the active set point, i.e., the set point determined by the state of the FSP-OP bit (MR13 OP[7]). The values in the registers for the inactive set point will be ignored by the device, and may be changed without affecting device operation.

### 2.5.3.1. Read and Write Latencies (Frequency Ranges for RL, WL, and nWR Settings)

Read Latency		Write Latency		nWR	nRTP	Freq. limit (Greater than)	Freq. limit (Same or less than)	Notes
No DBI	w/ DBI	Set "A"	Set "B"					
6	6	4	4	6	8	10	266	1,2,3,4 ,5,6
10	12	6	8	10	8	266	533	
14	16	8	12	16	8	533	800	
20	22	10	18	20	8	800	1066	
24	28	12	22	24	10	1066	1333	
28	32	14	26	30	12	1333	1600	
32	36	16	30	34	14	1600	1866	
36	40	18	34	40	16	1866	2133	
<i>nCK</i>	<i>nCK</i>	<i>nCK</i>	<i>nCK</i>	<i>nCK</i>	<i>nCK</i>	<i>MHz</i>	<i>MHz</i>	

Notes:

1. The LPDDR4-SDRAM device should not be operated at a frequency above the Upper Frequency Limit, or below the Lower Frequency Limit, shown for each RL, WL, nRTP, or nWR value.
2. DBI for Read operations is enabled in MR3-OP[6]. When MR3-OP[6]=0, then the "No DBI" column should be used for Read Latency. When MR3-OP[6]=1, then the "w/DBI" column should be used for Read Latency.
3. Write Latency Set "A" and Set "B" is determined by MR2-OP[6]. When MR2-OP[6]=0, then Write Latency Set "A" should be used. When MR2-OP[6]=1, then Write Latency Set "B" should be used.
4. The programmed value of nWR is the number of clock cycles the LPDDR4-SDRAM device uses to determine the starting point of an internal Pre-charge operation after a Write burst with AP (auto-pre-charge) enabled. It is determined by RU(tWR/tCK).
5. The programmed value of nRTP is the number of clock cycles the LPDDR4-SDRAM device uses to determine the starting point of an internal Pre-charge operation after a Read burst with AP (auto-pre-charge) enabled. It is determined by RU(tRTP/tCK).
6. nRTP shown in this table is valid for BL16 only. For BL32, the SDRAM will add 8 clocks to the nRTP value before starting a pre-charge.

### 2.5.4. MR3 Register Information (MA[5:0] = 03H)

OP[7]	OP[6]	OP[5]	OP[4]	OP[3]	OP[2]	OP[1]	OP[0]
DBI-WR	DBI-RD	PDDS			PPRP	WR-PST	PU-CAL

Function	Register Type	Operand	Data	Notes
PU-CAL (Pull-up Calibration Point)	Write only	OP[0]	0B: VDDQ*0.6 1B: VDDQ*0.5 (default)	1,4
WR-PST (Write Post-amble length)		OP[1]	0B: WR Post-amble = 0.5*tCK (default) 1B: WR Post-amble = 1.5*tCK (Vendor Specific)	2,3,5
Post Package Repair Protection		OP[2]	0B: PPR Protection Disabled (Default) 1B: PPR Protection Enabled	5
PDDS (Pull-down Drive Strength)		OP[5:3]	000B: RFU 001B: RZQ/1 010B: RZQ/2 011B: RZQ/3 100B: RZQ/4 101B: RZQ/5 110B: RZQ/6 (default) 111B: Reserved	1,2,3
DBI-RD (DBI-Read Enable)		OP[6]	0B: Disabled (default) 1B: Enabled	2,3
DBI-WR (DBI-WR Enable)		OP[7]	0B: Disabled (default) 1B: Enabled	2,3

- All values are "typical". The actual value after calibration will be within the specified tolerance for a given voltage and temperature. Re-calibration may be required as voltage and temperature vary.
- There are two physical registers assigned to each bit of this MR parameter, designated set point 0 and set point 1. Only the registers for the set point determined by the state of the FSP-WR bit (MR13 OP[6]) will be written to with an MRW command to this MR address.
- There are two physical registers assigned to each bit of this MR parameter, designated set point 0 and set point 1. The device will operate only according to the values stored in the registers for the active set point, i.e., the set point determined by the state of the FSP-OP bit (MR13 OP[7]). The values in the registers for the inactive set point will be ignored by the device, and may be changed without affecting device operation.
- PU-CAL setting is required as the same value for both Ch.A and Ch.B before ZQCAL start command.
- If MR3 OP[2] is set to 1b then PPR protection mode is enabled. The PPR Protection bit is a sticky bit and can only be set to 0b by power on reset. MR4 OP[4] controls entry to PPR Mode. If PPR protection is enabled then DRAM will not allow writing of 1 to MR4 OP[4].

### 2.5.5. MR4 Register Information (MA[5:0] = 04H)

OP[7]	OP[6]	OP[5]	OP[4]	OP[3]	OP[2]	OP[1]	OP[0]
TUF	Thermal Offset		PPRE	SR Abort	Refresh Rate		

Function	Register Type	Operand	Data	Notes
Refresh Rate	Read	OP[2:0]	000B: SDRAM Low temperature operating limit exceeded 001B: 4x refresh 010B: 2x refresh 011B: 1x refresh (default) 100B: 0.5x refresh 101B: 0.25x refresh, no-rating 110B: 0.25x refresh, with de-rating 111B: SDRAM High temperature operating limit exceeded	1,2,3,4,7,8,9
Self Refresh Abort	Write	OP[3]	0B: Disabled (default) 1B: Enabled	9
PPRE (Post-package repair entry/exit)	Write	OP[4]	0B: Exit PPR mode (default) 1B: Enter PPR mode	5,9
Thermal Offset	Write	OP[6:5]	00B: No offset, 0-5°C gradient (default) 01B: 5°C offset, 5-10°C gradient 10B: 10°C offset, 10-15°C gradient 11B: Reserved	
TUF (Temperature Update Flag)	Read	OP[7]	0B: No change in OP[2:0] since last MR4 read (default) 1B: Change in OP[2:0] since last MR4 read	6,7,8

- The refresh rate for each MR4-OP[2:0] setting applies to tREFI, tREFIpb, and tREFW. If OP[2]=0B, the device temperature is less or equal to 85°C. Other values require either a longer (2x, 4x) refresh interval at lower temperatures, or a shorter (0.5x, 0.25x) refresh interval at higher temperatures. If OP[2]=1, the device temperature is greater than 85°C.
- At higher temperatures (>85°C), AC timing de-rating may be required. If de-rating is required the LPDDR4-SDRAM will set OP[2:0]=110B. See de-rating timing requirements in the AC Timing section.
- DRAM vendors may or may not report all of the possible settings over the operating temperature range of the device. Each vendor guarantees that their device will work at any temperature within the range using the refresh interval requested by their device.
- The device may not operate properly when OP[2:0]=000B or 111B.
- Post-package repair can be entered or exited by writing to OP[4].
- When OP[7]=1, the refresh rate reported in OP[2:0] has changed since the last MR4 read. A mode register read from MR4 will reset OP[7] to '0'.
- OP[7]=0 at power-up. OP[2:0] bits are undefined at power-up.
- See the section on "Temperature Sensor" for information on the recommended frequency of reading MR4.
- OP[6:3] bits are that can be written in this register. All other bits will be ignored by the DRAM during a MRW to this register

### 2.5.6. MR5 Register Information (MA[5:0] = 05H)

OP[7]	OP[6]	OP[5]	OP[4]	OP[3]	OP[2]	OP[1]	OP[0]
LPDDR4 Manufacturer ID							

Function	Register Type	Operand	Data	Notes
LPDDR4 Manufacturer ID	Read-only	OP[7:0]	00000110B : SK hynix	

### 2.5.7. MR6 Register Information (MA[5:0] = 06H)

OP[7]	OP[6]	OP[5]	OP[4]	OP[3]	OP[2]	OP[1]	OP[0]
Revision ID-1							

Function	Register Type	Operand	Data	Notes
LPDDR4 Revision ID-1	Read-only	OP[7:0]	00000000B: A-version 00000001B: B-version	1

1. MR6 Opcode value for this device : [00000100B]

### 2.5.8. MR7 Register Information (MA[5:0] = 07H)

OP[7]	OP[6]	OP[5]	OP[4]	OP[3]	OP[2]	OP[1]	OP[0]
Revision ID-2							

Function	Register Type	Operand	Data	Notes
LPDDR4 Revision ID-1	Read-only	OP[7:0]	00000000B: A-version 00000001B: B-version	1

1. MR7 Opcode value for this device : [00000000B]

### 2.5.9. MR8 Register Information (MA[5:0] = 08H)

OP[7]	OP[6]	OP[5]	OP[4]	OP[3]	OP[2]	OP[1]	OP[0]
IO Width		Density				Type	

Function	Register Type	Operand	Data	Notes
Type	Read-only	OP[1:0]	00B: S16 SDRAM (16n pre-fetch) 01B: Low VDDQ(0.6V) Support All Others: Reserved	
Density		OP[5:2]	0000B: 4Gb per die (2Gb per channel) 0001B: 6Gb per die (3Gb per channel) 0010B: 8Gb per die (4Gb per channel) 0011B: 12Gb per die (6Gb per channel) 0100B: 16Gb per die (8Gb per channel) 0101B: 24Gb per die (12Gb per channel) 0110B: 32Gb per die (16Gb per channel) All Others: Reserved	
IO Width		OP[7:6]	00B: x16 (per channel) All Others: Reserved	

### 2.5.10. MR9 Register Information (MA[5:0] = 09H)

OP[7]	OP[6]	OP[5]	OP[4]	OP[3]	OP[2]	OP[1]	OP[0]
Vendor Specific Test Register							

1. Only 00H should be written to this register.

### 2.5.11. MR10 Register Information (MA[5:0] = 0AH)

OP[7]	OP[6]	OP[5]	OP[4]	OP[3]	OP[2]	OP[1]	OP[0]
RFU							ZQ Reset

Function	Register Type	Operand	Data	Notes
ZQ Reset	Write-only	OP[0]	0B: Normal Operation (Default) 1B: ZQ Reset	1,2

1. See the AC Timing tables for calibration latency and timing
2. If the ZQ-pin is connected to VDDQ through RZQ, either the ZQ calibration function or default calibration (via ZQ-Reset) is supported. If the ZQ-pin is connected to VSS, the device operates with default calibration, and ZQ calibration commands are ignored. In both cases, the ZQ connection shall not change after power is applied to the device.

### 2.5.12. MR11 Register Information (MA[5:0] = 0BH)

OP[7]	OP[6]	OP[5]	OP[4]	OP[3]	OP[2]	OP[1]	OP[0]
DQ ODT- nt	CA ODT			DQ ODT- nt	DQ ODT		

Function	Register Type	Operand	Data	Notes
DQ ODT (DQ Bus Receiver On-Die-Termination)	Write-only	OP[2:0]	000B: Disable (Default) 001B: RZQ/1 010B: RZQ/2 011B: RZQ/3 100B: RZQ/4 101B: RZQ/5 110B: RZQ/6 111B: RFU	1,2,3
DQ ODTnt		OP[7,3]	00B: Disable (Default) 01B: RZQ/3 10B: RZQ/5 11B: RZQ/6	1,2,3,4
CA ODT (CA Bus Receiver On-Die-Termination)		OP[6:4]	0000B: Disable (Default) 0001B: RZQ/1 0010B: RZQ/2 0011B: RZQ/3 0100B: RZQ/4 0101B: RZQ/5 0110B: RZQ/6 0111B: RFU	1,2,3

- All values are "typical". The actual value after calibration will be within the specified tolerance for a given voltage and temperature. Re-calibration may be required as voltage and temperature vary.
- There are two physical registers assigned to each bit of this MR parameter, designated set point 0 and set point 1. Only the registers for the set point determined by the state of the FSP-WR bit (MR13 OP[6]) will be written to with an MRW command to this MR address.
- There are two physical registers assigned to each bit of this MR parameter, designated set point 0 and set point 1. The device will operate only according to the values stored in the registers for the active set point, i.e., the set point determined by the state of the FSP-OP bit (MR13 OP[7]). The values in the registers for the inactive set point will be ignored by the device, and may be changed without affecting device operation.
- ODT for non-target DRAM is optional.

### 2.5.13. MR12 Register Information (MA[5:0] = 0CH)

OP[7]	OP[6]	OP[5]	OP[4]	OP[3]	OP[2]	OP[1]	OP[0]
CBT Mode	VR-CA	VREF(ca)					

Function	Register Type	Operand	Data	Notes
VREF(ca) (VREF(ca) Setting)	Read/Write	OP[5:0]	000000B: -- Thru -- 110010B: See table below All Others: Reserved	1,2,3,5 ,6
VREF(ca) Range		OP[6]	0B: VREF(ca) Range[0] enabled 1B: VREF(ca) Range[1] enabled (default)	1,2,4,5 ,6
CBT Mode		OP[7]	0B: Mode1 (Default) 1B: Mode2	7

1. This register controls the VREF(ca) levels for Frequency-Set-Point[1:0]. Values from either VR(ca)[0] or VR(ca)[1] may be selected by setting OP[6] appropriately.
2. A read to this register places the contents of OP[7:0] on DQ[7:0]. Any RFU bits and unused DQ's shall be set to '0'. See the section on MRR Operation.
3. A write to OP[5:0] sets the internal VREF(ca) level for FSP[0] when MR13 OP[6]=0B, or sets FSP[1] when MR13 OP[6]=1B. The time required for VREF(ca) to reach the set level depends on the step size from the current level to the new level. See the section on VREF(ca) training for more information.
4. A write to OP[6] switches the LPDDR4-SDRAM between two internal VREF(ca) ranges. The range (Range[0] or Range[1]) must be selected when setting the VREF(ca) register. The value, once set, will be retained until overwritten, or until the next power-on or RESET event.
5. There are two physical registers assigned to each bit of this MR parameter, designated set point 0 and set point 1. Only the registers for the set point determined by the state of the FSP-WR bit (MR13 OP[6]) will be written to with an MRW command to this MR address, or read from with an MRR command to this address.
6. There are two physical registers assigned to each bit of this MR parameter, designated set point 0 and set point 1. The device will operate only according to the values stored in the registers for the active set point, i.e., the set point determined by the state of the FSP-OP bit (MR13 OP[7]). The values in the registers for the inactive set point will be ignored by the device, and may be changed without affecting device operation.
7. This field (MR12 OP[7]) is only available in Byte-mode Package and its mixed package (x8 2ch device)



**Table - VREF Settings for Range[0] and Range[1]**

Function	Operand	Range[0] Values (% of VDDQ)		Range[1] Values (% of VDDQ)		Notes
VREF Settings for MR12	OP[5:0]	000000B: 15.0%	011010B: 30.5%	000000B: 32.9%	011010B: 48.5%	1,2,3
		000001B: 15.6%	011011B: 31.1%	000001B: 33.5%	011011B: 49.1%	
		000010B: 16.2%	011100B: 31.7%	000010B: 34.1%	011100B: 49.7%	
		000011B: 16.8%	011101B: 32.3%	000011B: 34.7%	011101B: 50.3%	
		000100B: 17.4%	011110B: 32.9%	000100B: 35.3%	011110B: 50.9%	
		000101B: 18.0%	011111B: 33.5%	000101B: 35.9%	011111B: 51.5%	
		000110B: 18.6%	100000B: 34.1%	000110B: 36.5%	100000B: 52.1%	
		000111B: 19.2%	100001B: 34.7%	000111B: 37.1%	100001B: 52.7%	
		001000B: 19.8%	100010B: 35.3%	001000B: 37.7%	100010B: 53.3%	
		001001B: 20.4%	100011B: 35.9%	001001B: 38.3%	100011B: 53.9%	
		001010B: 21.0%	100100B: 36.5%	001010B: 38.9%	100100B: 54.5%	
		001011B: 21.6%	100101B: 37.1%	001011B: 39.5%	100101B: 55.1%	
		001100B: 22.2%	100110B: 37.7%	001100B: 40.1%	100110B: 55.7%	
		001101B: 22.8%	100111B: 38.3%	001101B: 40.7%	100111B: 56.3%	
		001110B: 23.4%	101000B: 38.9%	001110B: 41.3%	101000B: 56.9%	
		001111B: 24.0%	101001B: 39.5%	001111B: 41.9%	101001B: 57.5%	
		010000B: 24.6%	101010B: 40.1%	010000B: 42.5%	101010B: 58.1%	
		010001B: 25.1%	101011B: 40.7%	010001B: 43.1%	101011B: 58.7%	
		010010B: 25.7%	101100B: 41.3%	010010B: 43.7%	101100B: 59.3%	
		010011B: 26.3%	101101B: 41.9%	010011B: 44.3%	101101B: 59.9%	
		010100B: 26.9%	101110B: 42.5%	010100B: 44.9%	101110B: 60.5%	
		010101B: 27.5%	101111B: 43.1%	010101B: 45.5%	101111B: 61.1%	
		010110B: 28.1%	110000B: 43.7%	010110B: 46.1%	110000B: 61.7%	
		010111B: 28.7%	110001B: 44.3%	010111B: 46.7%	110001B: 62.3%	
		011000B: 29.3%	110010B: 44.9%	011000B: 47.3%	110010B: 62.9%	
		011001B: 29.9%	All Others: Reserved	011001B: 47.9%	All Others: Reserved	

1. These values may be used for MR12 OP[5:0] to set the VREF(ca) levels in the LPDDR4-SDRAM.
2. The range may be selected in the MR12 register by setting OP[6] appropriately.
3. The MR12 registers represents either FSP[0] or FSP[1]. Two frequency-set-points each for CA and DQ are provided to allow for faster switching between terminated and un-terminated operation, or between different high-frequency setting which may use different terminations values.

### 2.5.14. MR13 Register Information (MA[5:0] = 0DH)

OP[7]	OP[6]	OP[5]	OP[4]	OP[3]	OP[2]	OP[1]	OP[0]
FSP-OP	FSP-WR	DMD	RRO	VRCG	VRO	RPRE-TR	CBT

Function	Register Type	Operand	Data	Notes
CBT (Command Bus Training)	Write	OP[0]	0B: Normal Operation (default) 1B: Command Bus Training mode enabled	1
RPRE-TR (Read Preamble Training)		OP[1]	0B: Normal Operation (default) 1B: Read Preamble Training mode enabled	
VRO (Vref Output)		OP[2]	0B: Normal Operation (default) 1B: Output the Vref(ca) value on DQ[0] and the Vref(dq) value on DQ[1]	2
VRCG (VREF Current Generator)		OP[3]	0B: Normal Operation (default) 1B: VREF Fast Response (high current) mode	3
RRO (Refresh Rate Option)		OP[4]	0B: Disable MR4 OP[2:0] (default) 1B: Enable MR4 OP[2:0]	4,5
DMD (Data Mask Disable)		OP[5]	0B: Data Mask Operation Enabled (default) 1B: Data Mask Operation Disabled	6
FSP-WR (Frequency Set Point Write Enable)		OP[6]	0B: Frequency-Set-Point[0] (default) 1B: Frequency-Set-Point[1]	7
FSP-OP (Frequency Set Point Operation Mode)		OP[7]	0B: Frequency-Set-Point[0] (default) 1B: Frequency-Set-Point[1]	8

1. A write to set OP[0]=1 causes the LPDDR4-SDRAM to enter the VREF(ca) training mode. When OP[0]=1 and CKE goes LOW, commands are ignored and the contents of CA[5:0] are mapped to the DQ bus. CKE must be brought HIGH before doing a MRW to clear this bit (OP[0]=0) and return to normal operation. See the VREF(ca) training section for more information.
2. When set, the LPDDR4-SDRAM will output the VREF(ca) voltage on DQ[0] and the VREF(dq) voltage on DQ[1]. Only the "active" frequency-set-point, as defined by MR13 OP[7], will be output on the DQ pins. This function allows an external test system to measure the internal VREF levels.
3. When OP[3]=1, the VREF circuit uses a high-current mode to improve VREF settling time.
4. MR13 OP4 RRO bit is valid only when MR0 OP0 = 1. For LPDDR4 devices with MR0 OP0 = 0, MR4 OP[2:0] bits are not dependent on MR13 OP4.
5. When OP[4] = 0, only 001b and 010b in MR4 OP[2:0] are disabled. LPDDR4 devices must report 011b instead of 001b or 010b in this case. Controller should follow the refresh mode reported by MR4 OP[2:0], regardless of RRO setting. TCSR function does not depend on RRO setting.
6. When enabled (OP[5]=0B) data masking is enabled for the device. When disabled (OP[5]=1B), Masked Write Command is not allowed and it is illegal. See the Data Mask section for more information.
7. FSP-WR determines which frequency-set-point registers are accessed with MRW commands for the following functions: Vref(CA) Setting, Vref(CA) Range, Vref(DQ) Setting, Vref(DQ) Range, CA ODT Enable, CA ODT value, DQ ODT Enable, DQ ODT value, DQ Calibration Point, WL, RL, nWR, Read and Write Preamble, Read postamble, and DBI Enables.
8. FSP-OP determines which frequency-set-point register values are currently used to specify device operation for the following functions: Vref(CA) Setting, Vref(CA) Range, Vref(DQ) Setting, Vref(DQ) Range, CA ODT Enable, CA ODT value, DQ ODT Enable, DQ ODT value, DQ Calibration Point, WL, RL, nWR, Read and Write Preamble, Read postamble, and DBI Enables.

### 2.5.15. MR14 Register Information (MA[5:0] = 0EH)

OP[7]	OP[6]	OP[5]	OP[4]	OP[3]	OP[2]	OP[1]	OP[0]
RFU	VR(dq)	VREF(dq)					

Function	Register Type	Operand	Data	Notes
VREF(dq) Setting for Set Point[0]	Read / Write	OP[5:0]	000000B: -- Thru – 110010B: See table below All Others: Reserved	1,2,3,4 ,5,6
VREF(dq) Range		OP[6]	0B: VREF(dq) Range[0] enabled 1B: VREF(dq) Range[1] enabled (default)	1,2,3,4 ,5,6

1. This register controls the VREF(dq) levels for Frequency-Set-Point[1:0]. Values from either VR(dq)[0] or VR(dq)[1] may be selected by setting OP[6] appropriately.
2. A read (MRR) to this register places the contents of OP[7:0] on DQ[7:0]. Any RFU bits and unused DQ's shall be set to '0'. See the section on MRR Operation.
3. A write to OP[5:0] sets the internal VREF(dq) level for FSP[0] when MR13 OP[6]=0B, or sets FSP[1] when MR13 OP[6]=1B. The time required for VREF(dq) to reach the set level depends on the step size from the current level to the new level. See the section on VREF(dq) training for more information.
4. A write to OP[6] switches the LPDDR4-SDRAM between two internal VREF(dq) ranges. The range (Range[0] or Range[1]) must be selected when setting the VREF(dq) register. The value, once set, will be retained until overwritten, or until the next power-on or RESET event.
5. There are two physical registers assigned to each bit of this MR parameter, designated set point 0 and set point 1. Only the registers for the set point determined by the state of the FSP-WR bit (MR13 OP[6]) will be written to with an MRW command to this MR address, or read from with an MRR command to this address.
6. There are two physical registers assigned to each bit of this MR parameter, designated set point 0 and set point 1. The device will operate only according to the values stored in the registers for the active set point, i.e., the set point determined by the state of the FSP-OP bit (MR13 OP[7]). The values in the registers for the inactive set point will be ignored by the device, and may be changed without affecting device operation.

**Table - VREF Settings for Range[0] and Range[1]**

Function	Operand	Range[0] Values (% of VDDQ)		Range[1] Values (% of VDDQ)		Notes
VREF Settings for MR14	OP[5:0]	000000B: 15.0%	011010B: 30.5%	000000B: 32.9%	011010B: 48.5%	1,2,3
		000001B: 15.6%	011011B: 31.1%	000001B: 33.5%	011011B: 49.1%	
		000010B: 16.2%	011100B: 31.7%	000010B: 34.1%	011100B: 49.7%	
		000011B: 16.8%	011101B: 32.3%	000011B: 34.7%	011101B: 50.3%	
		000100B: 17.4%	011110B: 32.9%	000100B: 35.3%	011110B: 50.9%	
		000101B: 18.0%	011111B: 33.5%	000101B: 35.9%	011111B: 51.5%	
		000110B: 18.6%	100000B: 34.1%	000110B: 36.5%	100000B: 52.1%	
		000111B: 19.2%	100001B: 34.7%	000111B: 37.1%	100001B: 52.7%	
		001000B: 19.8%	100010B: 35.3%	001000B: 37.7%	100010B: 53.3%	
		001001B: 20.4%	100011B: 35.9%	001001B: 38.3%	100011B: 53.9%	
		001010B: 21.0%	100100B: 36.5%	001010B: 38.9%	100100B: 54.5%	
		001011B: 21.6%	100101B: 37.1%	001011B: 39.5%	100101B: 55.1%	
		001100B: 22.2%	100110B: 37.7%	001100B: 40.1%	100110B: 55.7%	
		001101B: 22.8%	100111B: 38.3%	001101B: 40.7%	100111B: 56.3%	
		001110B: 23.4%	101000B: 38.9%	001110B: 41.3%	101000B: 56.9%	
		001111B: 24.0%	101001B: 39.5%	001111B: 41.9%	101001B: 57.5%	
		010000B: 24.6%	101010B: 40.1%	010000B: 42.5%	101010B: 58.1%	
		010001B: 25.1%	101011B: 40.7%	010001B: 43.1%	101011B: 58.7%	
		010010B: 25.7%	101100B: 41.3%	010010B: 43.7%	101100B: 59.3%	
		010011B: 26.3%	101101B: 41.9%	010011B: 44.3%	101101B: 59.9%	
		010100B: 26.9%	101110B: 42.5%	010100B: 44.9%	101110B: 60.5%	
		010101B: 27.5%	101111B: 43.1%	010101B: 45.5%	101111B: 61.1%	
		010110B: 28.1%	110000B: 43.7%	010110B: 46.1%	110000B: 61.7%	
		010111B: 28.7%	110001B: 44.3%	010111B: 46.7%	110001B: 62.3%	
		011000B: 29.3%	110010B: 44.9%	011000B: 47.3%	110010B: 62.9%	
		011001B: 29.9%	All Others: Reserved	011001B: 47.9%	All Others: Reserved	

1. These values may be used for MR14 OP[5:0] to set the VREF(dq) levels in the LPDDR4-SDRAM.
2. The range may be selected in the MR14 register by setting OP[6] appropriately.
3. The MR14 registers represents either FSP[0] or FSP[1]. Two frequency-set-points each for CA and DQ are provided to allow for faster switching between terminated and un-terminated operation, or between different high-frequency setting which may use different terminations values.

### 2.5.16. MR15 Register Information (MA[5:0] = 0FH)

OP[7]	OP[6]	OP[5]	OP[4]	OP[3]	OP[2]	OP[1]	OP[0]
Lower Byte Invert Register for DQ Calibration							

Function	Register Type	Operand	Data	Notes
Lower Byte Invert for DQ Calibration	Write	OP[7:0]	The following values may be written for any operand OP[7:0], and will be applied to the corresponding DQ locations DQ[7:0] within a byte lane:  0B: Do not invert 1B: Invert the DQ Calibration patterns in MR32 and MR40  Default value for OP[7:0]=55H	1

Notes:

1. This register will invert the DQ Calibration pattern found in MR32 and MR40 for any single DQ, or any combination of DQ's. Example: If MR15 OP[7:0]=00010101B, then the DQ Calibration patterns transmitted on DQ[7,6,5,3,1] will not be inverted, but the DQ Calibration patterns transmitted on DQ[4,2,0] will be inverted.
2. DMI[0] is not inverted, and always transmits the "true" data contained in MR32/MR40.
3. No Data Bus Inversion (DBI) function is enacted during DQ Read Calibration, even if DBI is enabled in MR3-OP[6].

**Table - MR15 Invert Register Pin Mapping**

Pin	DQ0	DQ1	DQ2	DQ3	DMI0	DQ4	DQ5	DQ6	DQ7
MR15	OP0	OP1	OP2	OP3	No-invert	OP4	OP5	OP6	OP7

### 2.5.17. MR16 Register Information (MA[5:0] = 10H)

OP[7]	OP[6]	OP[5]	OP[4]	OP[3]	OP[2]	OP[1]	OP[0]
PASR Bank Mask							

Function	Register Type	Operand	Data	Notes
Bank[7:0] Mask	Write-only	OP[7:0]	0B: Bank Refresh enabled (default) : Unmasked 1B: Bank Refresh disabled : Masked	1

OP[n]	Bank Mask	8-Bank SDRAM
0	xxxxxx1	Bank 0
1	xxxxx1x	Bank 1
2	xxxx1xx	Bank 2
3	xxx1xxx	Bank 3
4	xx1xxxx	Bank 4
5	x1xxxxx	Bank 5
6	1xxxxxx	Bank 6
7	1xxxxxx	Bank 7

1. When a mask bit is asserted (OP[n]=1), refresh to that bank is disabled.
2. PASR bank masking is on a per channel basis. The two channels on the die may have different bank masking.

### 2.5.18. MR17 Register Information (MA[5:0] = 11H)

OP[7]	OP[6]	OP[5]	OP[4]	OP[3]	OP[2]	OP[1]	OP[0]
PASR Segment Mask							

Function	Register Type	Operand	Data	Notes
PASR Segment Mask	Write-only	OP[7:0]	0B: Segment Refresh enabled (default) 1B: Segment Refresh disabled	1

Seg- ment	OP[n]	Seg- ment Mask	4Gb	6Gb	8Gb	12Gb	16Gb	24Gb	32Gb
			R13:R11	R14:R12	R14:R12	R15:R13	R15:R13	TBD	TBD
			R14:R12 (Bytemode)	R15:R13 (Bytemode)	R15:R13 (Bytemode)	R16:R14 (Bytemode)	R16:R14 (Bytemode)	TBD	TBD
0	0	xxxxxxx1	000B						
1	1	xxxxxx1x	001B						
2	2	xxxxx1xx	010B						
3	3	xxx1xxx	011B						
4	4	xx1xxxx	100B						
5	5	xx1xxxxx	101B						
6	6	x1xxxxxx	110B	Not	110B	Not	110B	Not	110B
7	7	1xxxxxxx	111B	Allowed	111B	Allowed	111B	Allowed	111B

1. This table indicates the range of row addresses in each masked segment. "X" is don't care for a particular segment.
2. PASR segment-masking is on a per-channel basis. The two channels on the die may have different segment masking.

### 2.5.19. MR18 Register Information (MA[5:0] = 12H)

OP[7]	OP[6]	OP[5]	OP[4]	OP[3]	OP[2]	OP[1]	OP[0]
DQS Oscillator Count - LSB							

Function	Register Type	Operand	Data	Notes
DQS Oscillator (WR Training DQS Oscilla- tor)	Read-only	OP[7:0]	0:255 LSB DRAM DQS Oscillator Count	1,2,3

1. MR18 reports the LSB bits of the DRAM DQS Oscillator count. The DRAM DQS Oscillator count value is used to train DQS to the DQ data valid window. The value reported by the DRAM in this mode register can be used by the memory controller to periodically adjust the phase of DQS relative to DQ.
2. Both MR18 and MR19 must be read (MRR) and combined to get the value of the DQS Oscillator count.
3. A new MPC [Start DQS Oscillator] should be issued to reset the contents of MR18/MR19.

### 2.5.20. MR19 Register Information (MA[5:0] = 13H)

OP[7]	OP[6]	OP[5]	OP[4]	OP[3]	OP[2]	OP[1]	OP[0]
DQS Oscillator Count - MSB							

Function	Register Type	Operand	Data	Notes
DQS Oscillator (WR Training DQS Oscillator)	Read-only	OP[7:0]	0:255 MSB DRAM DQS Oscillator Count	1,2

1. MR19 reports the MSB bits of the DRAM DQS Oscillator count. The DRAM DQS Oscillator count value is used to train DQS to the DQ data valid window. The value reported by the DRAM in this mode register can be used by the memory controller to periodically adjust the phase of DQS relative to DQ.
2. Both MR18 and MR19 must be read (MRR) and combined to get the value of the DQS Oscillator count.
3. A new MPC [Start DQS Oscillator] should be issued to reset the contents of MR18/MR19.

### 2.5.21. MR20 Register Information (MA[5:0] = 14H)

OP[7]	OP[6]	OP[5]	OP[4]	OP[3]	OP[2]	OP[1]	OP[0]
Upper Byte Invert Register for DQ Calibration							

Function	Register Type	Operand	Data	Notes
Upper Byte Invert for DQ Calibration	Write	OP[7:0]	The following values may be written for any operand OP[7:0], and will be applied to the corresponding DQ locations DQ[15:8] within a byte lane:  0B: Do not invert 1B: Invert the DQ Calibration patterns in MR32 and MR40  Default value for OP[7:0]=55H	1,2

1. This register will invert the DQ Calibration pattern found in MR32 and MR40 for any single DQ, or any combination of DQ's. Example: If MR20 OP[7:0]=00010101B, then the DQ Calibration patterns transmitted on DQ[15,14,13,11,9] will not be inverted, but the DQ Calibration patterns transmitted on DQ[12,10,8] will be inverted.
2. DMI[1] is not inverted, and always transmits the "true" data contained in MR32/MR40.
3. No Data Bus Inversion (DBI) function is enacted during DQ Read Calibration, even if DBI is enabled in MR3-OP[6].

**Table - MR20 Invert Register Pin Mapping**

Pin	DQ8	DQ9	DQ10	DQ11	DMI1	DQ12	DQ13	DQ14	DQ15
MR20	OP0	OP1	OP2	OP3	No-invert	OP4	OP5	OP6	OP7

### 2.5.22. MR21 Register Information (MA[5:0] = 15H)

OP[7]	OP[6]	OP[5]	OP[4]	OP[3]	OP[2]	OP[1]	OP[0]
Vendor Specific Mode Register							

### 2.5.23. MR22 Register Information (MA[5:0] = 16H)

OP[7]	OP[6]	OP[5]	OP[4]	OP[3]	OP[2]	OP[1]	OP[0]
ODTD for x8_2ch (Byte) mode		ODTD-CA	ODTE-CS	ODTE-CK	SOC ODT		

Function	Register Type	Operand	Data	Notes
SoC ODT (Controller ODT Value for VOH calibration)	Write-only	OP[2:0]	000B: Disable (Default) 001B: RZQ/1 (illegal if MR3 OP[0]=0B) 010B: RZQ/2 011B: RZQ/3 (illegal if MR3 OP[0]=0B) 100B: RZQ/4 101B: RZQ/5 (illegal if MR3 OP[0]=0B) 110B: RZQ/6 (illegal if MR3 OP[0]=0B) 111B: RFU	1,2,3
ODTE-CK (CK ODT enabled for non-terminating rank)		OP[3]	ODT bond PAD is ignored 0B: ODT-CK Enable (Default) 1B: ODT-CK Disable	2,3,4
ODTE-CS (CS ODT enable for non-terminating rank)		OP[4]	ODT bond PAD is ignored 0B: ODT-CS Enable (Default) 1B: ODT-CS Disable	2,3,4
ODTD-CA (CA ODT termination disable)		OP[5]	ODT bond PAD is ignored 0B: ODT-CA Enable (Default) 1B: ODT-CA Disable	2,3,4
x8 ODTD[7:0] (CA/CLK ODT termination disable [7:0] Lower byte select)		OP[6]	x8 2ch only, [7:0] Byte selected Device 0B: ODT-CS/CA/CLK follows MR11 OP[6:4] & MR22 OP[5:3] (default) 1B: ODT-CS/CA/CLK Disabled (default)	2,3,4
x8 ODTD[15:8] (CA/CLK ODT termination disable [15:8] upper byte select)		OP[7]	x8 2ch only, [15:8] Byte selected Device 0B: ODT-CS/CA/CLK follows MR11 OP[6:4] & MR22 OP[5:3] (default) 1B: ODT-CS/CA/CLK Disabled (default)	2,3,4

Notes:

- All values are "typical".
- There are two physical registers assigned to each bit of this MR parameter, designated set point 0 and set point 1. Only the registers for the set point determined by the state of the FSP-WR bit (MR13 OP[6]) will be written to with an MRW command to this MR address, or read from with an MRR command to this address.
- There are two physical registers assigned to each bit of this MR parameter, designated set point 0 and set point 1. The device will operate only according to the values stored in the registers for the active set point, i.e., the set point determined by the state of the FSP-OP bit (MR13 OP[7]). The values in the registers for the inactive set point will be ignored by the device, and may be changed without affecting device operation.
- LPDDR4X device ignore ODT bond PAD.



### LPDDR4X Byte Mode Device (MR11 OP[6:4]≠000<sub>B</sub> Case)

Truth Table(T=Terminated)

MR22	ODTD byte mode		ODT CA	ODT CS	ODT CK	ODT PAD Ignore					
	OP[7]	OP[6]	OP[5]	OP[4]	OP[3]	CA		CS		CK	
						0B	1B	0B	1B	0Bz	1B
LPD4X	0	0	0	0	0	T	T	T	T	T	T
	0	0	0	0	1	T	T	T	T		
	0	0	0	1	0	T	T			T	T
	0	0	0	1	1	T	T				
	0	0	1	0	0			T	T	T	T
	0	0	1	0	1			T	T		
	0	0	1	1	0					T	T
	0	0	1	1	1						
	0	1	0	0	0			T		T	
	0	1	0	0	1			T		T	
	0	1	0	1	0			T			T
	0	1	0	1	1			T			
	0	1	1	0	0					T	
	0	1	1	0	1					T	
	0	1	1	1	0						T
	0	1	1	1	1						
	1	0	0	0	0		T		T		T
	1	0	0	0	1		T		T		
	1	0	0	1	0		T				T
	1	0	0	1	1		T				
	1	0	1	0	0				T		T
	1	0	1	0	1				T		
	1	0	1	1	0						T
	1	0	1	1	1						

Notes:

1. T means "terminated" condition. Blank is "un-terminated"

### 2.5.24. MR23 Register Information (MA[5:0] = 17H)

OP[7]	OP[6]	OP[5]	OP[4]	OP[3]	OP[2]	OP[1]	OP[0]
DQS oscillator run time setting							

Function	Register Type	Operand	Data	Notes
DQS oscillator run time	Write	OP[7:0]	00000000B: DQS timer stops via MPC Command (Default) 00000001B: DQS timer stops automatically at 16th clocks after timer start 00000010B: DQS timer stops automatically at 32nd clocks after timer start 00000011B: DQS timer stops automatically at 48th clocks after timer start 00000100B: DQS timer stops automatically at 64th clocks after timer start ----- Thru ----- 00111111B: DQS timer stops automatically at (63X16)th clocks after timer start 01XXXXXXB: DQS timer stops automatically at 2048th clocks after timer start 10XXXXXXB: DQS timer stops automatically at 4096th clocks after timer start 11XXXXXXB: DQS timer stops automatically at 8192nd clocks after timer start	1, 2

Note:

- MPC command with OP[6:0]=1001101B (Stop DQS Interval Oscillator) stops DQS interval timer in case of MR23 OP[7:0] = 00000000B.
- MPC command with OP[6:0]=1001101B (Stop DQS Interval Oscillator) is illegal with non-zero values in MR23 OP[7:0].

### 2.5.25. MR24 Register Information (MA[5:0] = 18H)

OP[7]	OP[6]	OP[5]	OP[4]	OP[3]	OP[2]	OP[1]	OP[0]
TRR Mode	TRR Mode Bank Address			Unlimited MAC	MAC Value		

Function	Register Type	Operand	Data	Notes
MAC Value	Read	OP[2:0]	000B: Unknown when bit OP3 =0 (note 1) Unlimited when bit OP3=1 (note 2) 001B: 700K 010B: 600K 011B: 500K 100B: 400K 101B: 300K 110B: 200K 111B: Reserved	
Unlimited MAC		OP[3]	0B: OP[2:0] define MAC value 1B: Unlimited MAC value (note 2, note 3)	

Function	Register Type	Operand	Data	Notes
TRR Mode BAN	Write	OP[6:4]	000B: Bank 0 001B: Bank 1 010B: Bank 2 011B: Bank 3 100B: Bank 4 101B: Bank 5 110B: Bank 6 111B: Bank 7	
TRR Mode		OP[7]	0B: Disabled (default) 1B: Enabled	

Note:

1. Unknown means that the device is not tested for tMAC and pass/fail value is unknown.
2. There is no restriction to number of activates.
3. MR24 OP [2:0] is set to zero.

### 2.5.26. MR25 Register Information (MA[5:0] = 19H)

OP[7]	OP[6]	OP[5]	OP[4]	OP[3]	OP[2]	OP[1]	OP[0]
Bank 7	Bank 6	Bank 5	Bank 4	Bank 3	Bank 2	Bank 1	Bank 0

Function	Register Type	Operand	Data	Notes
PPR Resource	Read	OP[7:0]	0B: PPR Resource is not available 1B: PPR Resource is available	

### 2.5.27. MR26:31 Register Information (MA[5:0] = 1AH:1FH)

OP[7]	OP[6]	OP[5]	OP[4]	OP[3]	OP[2]	OP[1]	OP[0]
Reserved							

### 2.5.28. MR32 Register Information (MA[5:0] = 20H)

OP[7]	OP[6]	OP[5]	OP[4]	OP[3]	OP[2]	OP[1]	OP[0]
DQ Calibration Pattern "A" (default = 5AH)							

Function	Register Type	Operand	Data	Notes
Return DQ Calibration Pattern MR32 + MR40	Write	OP[7:0]	XB: An MPC command with OP[6:0]=0000011B causes the device to return the DQ Calibration Pattern contained in this register and (followed by) the contents of MR40. A default pattern "5AH" is loaded at power-up or RESET, or the pattern may be overwritten with a MRW to this register. The contents of MR15 and MR20 will invert the data pattern for a given DQ (See MR15 for more information)	

### 2.5.29. MR33:36 Register Information (MA[5:0] = 21H:24H)

OP[7]	OP[6]	OP[5]	OP[4]	OP[3]	OP[2]	OP[1]	OP[0]
Do Not Use							

### 2.5.30. MR37 Register Information (MA[5:0] = 25H) Optional

OP[7]	OP[6]	OP[5]	OP[4]	OP[3]	OP[2]	OP[1]	OP[0]
RFU						VDDQ Level	

Function	Register Type	Operand	Data	Notes
VDDQ Level	Write	OP[1:0]	Valid for Low VDDQ device 00B: VDDQ = 1.1V valid for MR8 OP[2:0] = 11B 10B: VDDQ = 0.6V All Others: Reserved	1

Notes:

- MR37 OP[1:0] is ignored when MR8 OP[0:1] is 00B and 01B.

### 2.5.31. MR38:39 Register Information (MA[5:0] = 26H:27H)

OP[7]	OP[6]	OP[5]	OP[4]	OP[3]	OP[2]	OP[1]	OP[0]
Do Not Use							

### 2.5.32. MR40 Register Information (MA[5:0] = 28H)

OP[7]	OP[6]	OP[5]	OP[4]	OP[3]	OP[2]	OP[1]	OP[0]
DQ Calibration Pattern "B" (default = 3CH)							

Function	Register Type	Operand	Data	Notes
Return DQ Calibration Pattern MR32 + MR40	Write	OP[7:0]	XB: A default pattern "3CH" is loaded at power-up or RESET, or the pattern may be overwritten with a MRW to this register. See MR32 for more information.	1,2,3,4

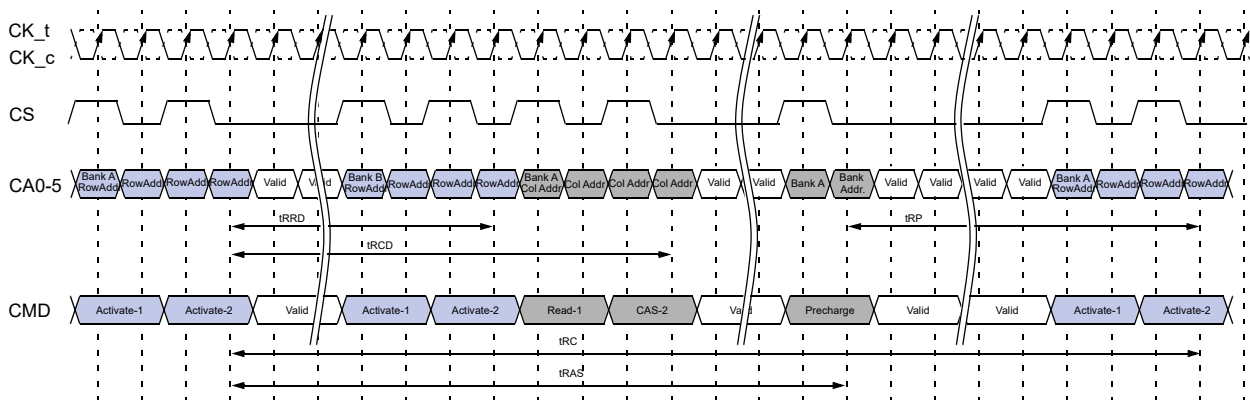
Notes:

1. The pattern contained in MR40 is concatenated to the end of MR32 and transmitted on DQ[15:0] and DMI[1:0] when DQ Read Calibration is initiated via a MPC command. The pattern transmitted serially on each data lane, organized "little endian" such that the low-order bit in a byte is transmitted first. If the data pattern in MR40 is 27H, then the first bit transmitted will be a '1', followed by '1', '1', '0', '0', '1', '0', and '0'. The bit stream will be 00100111B.
2. MR15 and MR22 may be used to invert the MR32/MR40 data patterns on the DQ pins. See MR15 and MR22 for more information. Data is never inverted on the DMI[1:0] pins.
3. The data pattern is not transmitted on the DMI[1:0] pins if DBI-RD is disabled via MR3-OP[6].
4. No Data Bus Inversion (DBI) function is enacted during DQ Read Calibration, even if DBI is enabled in MR3-OP[6].

### 3. LPDDR4 Command Definitions and Timing Diagrams

#### 3.1. Activate Command

The ACTIVATE command is composed of two consecutive commands, Activate-1 command and Activate-2. Activate-1 command is issued by holding CS HIGH, CA0 HIGH and CA1 LOW at the first rising edge of the clock and Activate-2 command issued by holding CS HIGH, CA0 HIGH and CA1 HIGH at the first rising edge of the clock. The bank addresses BA0, BA1 and BA2 are used to select desired bank. Row addresses are used to determine which row to activate in the selected bank. The ACTIVATE command must be applied before any READ or WRITE operation can be executed. The device can accept a READ or WRITE command at  $t_{RCD}$  after the ACTIVATE command is issued. After a bank has been activated it must be precharged before another ACTIVATE command can be applied to the same bank. The bank active and precharge times are defined as  $t_{RAS}$  and  $t_{RP}$  respectively. The minimum time interval between ACTIVATE commands to the same bank is determined by the RAS cycle time of the device ( $t_{RC}$ ). The minimum time interval between ACTIVATE commands to different banks is  $t_{RRD}$ .



**Figure - Activate Command Timing Example**

Note : A PRECHARGE command uses  $t_{RPab}$  timing for all-bank PRECHARGE and  $t_{RPpb}$  timing for single-bank PRECHARGE. In this figure,  $t_{RP}$  is used to denote either all-bank PRECHARGE or a single-bank PRECHARGE.

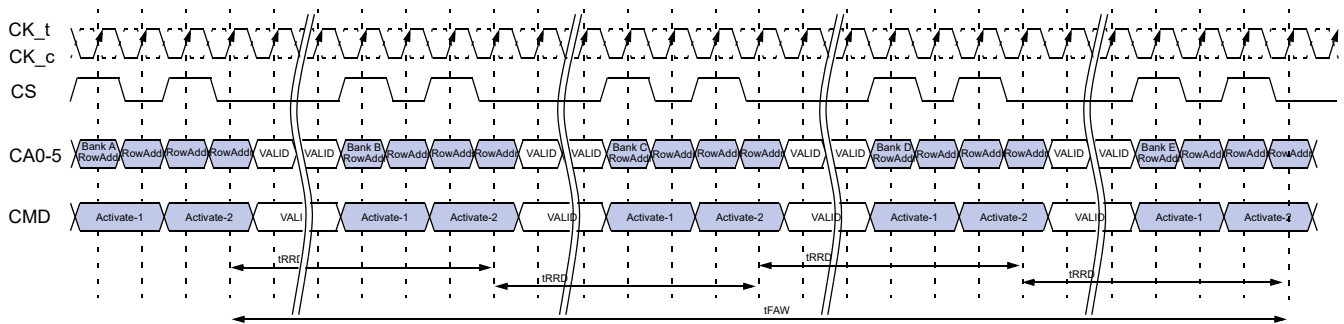
#### 3.1.1. 8-Bank Device Operation

Certain restrictions on operation of the 8-bank LPDDR4 devices must be observed. There are two rules: One rule restricts the number of sequential ACTIVATE commands that can be issued; the other provides more time for RAS precharge for a PRECHARGE ALL command. The rules are as follows:

**8 bank device Sequential Bank Activation Restriction:** No more than 4 banks may be activated (or refreshed, in the case of REFpb) in a rolling tFAW window. The number of clocks in a tFAW period is dependent upon the clock frequency, which may vary. If the clock frequency is not changed over this period, converting clocks is done by dividing  $tFAW[ns]$  by  $tCK[ns]$ , and rounding up to the next integer value. As

an example of the rolling window, if  $RU(tFAW/tCK)$  is 10 clocks, and an ACTIVATE command is issued in clock  $n$ , no more than three further ACTIVATE commands can be issued at or between clock  $n + 1$  and  $n + 9$ . REFpb also counts as bank activation for purposes of tFAW. If the clock frequency is changed during the tFAW period, the rolling tFAW window may be calculated in clock cycles by adding up the time spent in each clock period. The tFAW requirement is met when the previous  $n$  clock cycles exceeds the tFAW time.

**The 8-Bank Device Precharge-All Allowance:** tRP for a PRECHRG ALL command must equal tRPab, which is greater than tRPpb.



**Figure - tFAW Timing Example**

### 3.2. Read and Write Access Operations

After a bank has been activated, a read or write command can be executed. This is accomplished by asserting CKE asynchronously, with CS and CA[5:0] set to the proper state (see Command Truth Table) at a rising edge of CK.

The LPDDR4-SDRAM provides a fast column access operation. A single Read or Write command will initiate a burst read or write operation, where data is transferred to/from the DRAM on successive clock cycles. Burst interrupts are not allowed, but the optimal burst length may be set on the fly (see command truth table).

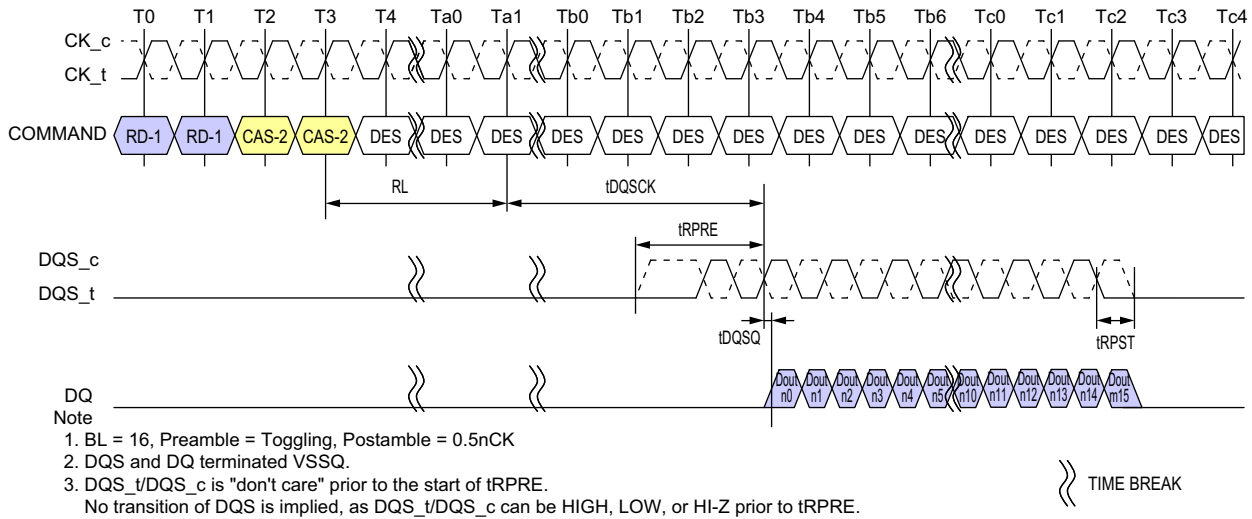
### 3.3. Read Preamble and Postamble

The DQS strobe for the LPDDR4-SDRAM requires a pre-ambble prior to the first latching edge (the rising edge of DQS\_t with DATA "valid"), and it requires a post-ambble after the last latching edge. The pre-ambble and post-ambble lengths are set via mode register writes (MRW).

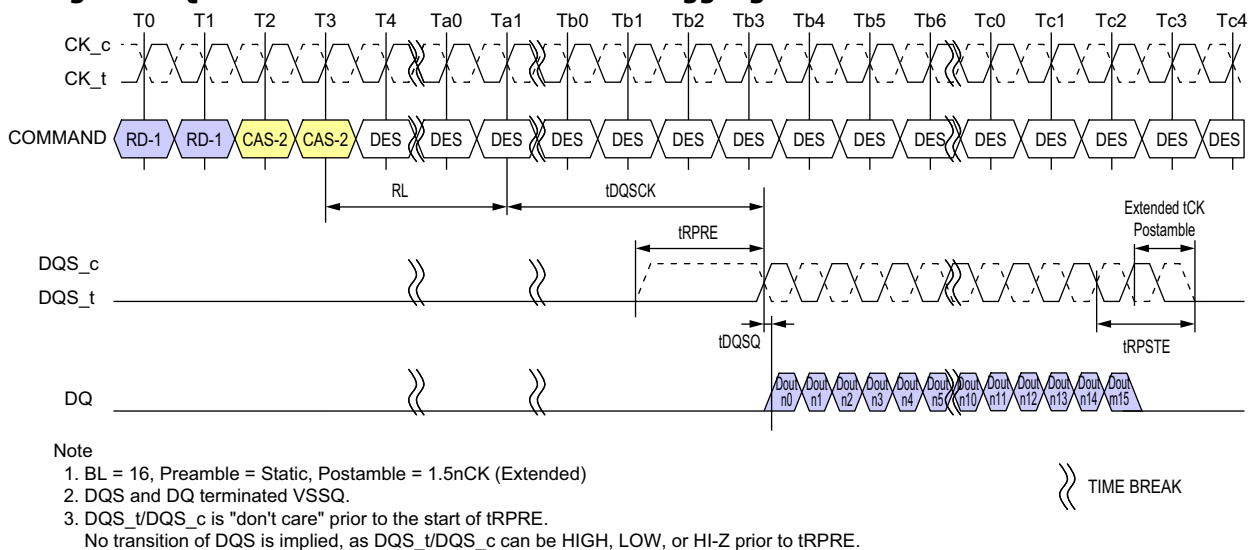
For READ operations the pre-ambble is  $2 \cdot tCK$ , but the pre-ambble is static (no-toggle) or toggling, selectable via mode register.

LPDDR4 will have a DQS Read post-ambble of  $0.5 \cdot tCK$  (or extended to  $1.5 \cdot tCK$ ). Standard DQS postamble will be

0.5\*tCK driven by the DRAM for Reads. A mode register setting instructs the DRAM to drive an additional (extended) one cycle DQS Read post-amble. The drawings below show examples of DQS Read post-amble for both standard (tRPST) and extended (tRPSTE) post-amble operation.



**Figure - DQS Read Preamble and Postamble: Toggling Preamble and 0.5nCK Postamble**



**Figure - DQS Read Preamble and Postamble: Static Preamble and 1.5nCK Postamble**

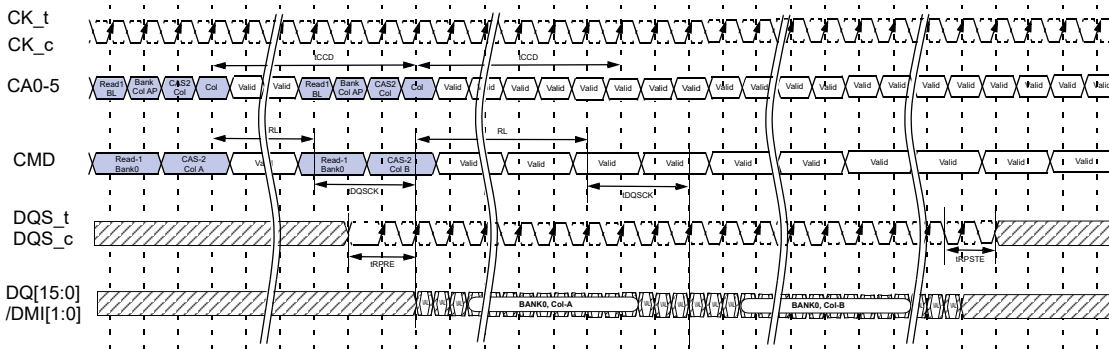
### 3.4. Burst Read Operation

A burst Read command is initiated with CKE, CS, and CA[5:0] asserted to the proper state at the rising edge of CK, as defined by the Command Truth Table. The command address bus inputs determine the starting column address for the burst. The two low-order address bits are not transmitted on the CA bus and are implied to be "0", so that the starting burst address is always a multiple of four (ex. 0x0, 0x4, 0x8, 0xC). The read latency (RL) is defined from the last rising edge of the clock that completes a read command (Ex: the second rising edge of the CAS-2 command) to the rising edge of the clock from which the tDQSK delay is measured. The first valid data is available RL \* tCK + tDQSK + tDQSQ after the rising edge of Clock that



completes a read command. The data strobe output is driven tRPRE before the first valid rising strobe edge. The first data-bit of the burst is synchronized with the first valid (i.e. post-preamble) rising edge of the data strobe. Each subsequent dataout appears on each DQ pin, edge-aligned with the data strobe. At the end of a burst the DQS signals are driven for another half cycle post-amble, or for a 1.5-cycle postamble if the programmable post-amble bit is set in the mode register. The RL is programmed in the mode registers. Pin timings for the data strobe are measured relative to the cross-point of DQS<sub>t</sub> and DQS<sub>c</sub>.

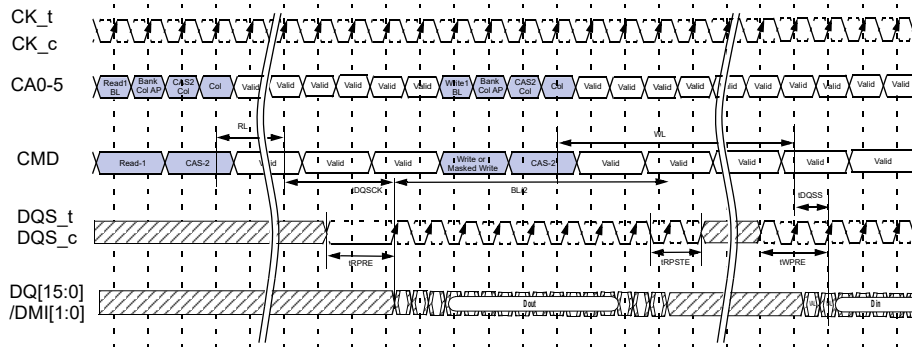
**Figure - Burst Read Timing. BL=16, Toggling tRPRE, Extended tRPST**



**Notes:**

- DES commands are shown for ease of illustration; other commands may be valid at these times.

**Figure - Burst Read followed by Burst Write. BL=16, Non-toggling tRPRE, Extended tRPST**



**Notes:**

- DES commands are shown for ease of illustration; other commands may be valid at these times.

The minimum time from a Burst Read command to a Write or MASK WRITE command is defined by the read latency (RL) and the burst length (BL). Minimum READ-to-WRITE or MASK WRITE latency is defined with tRTW parameter and it is as following equation:

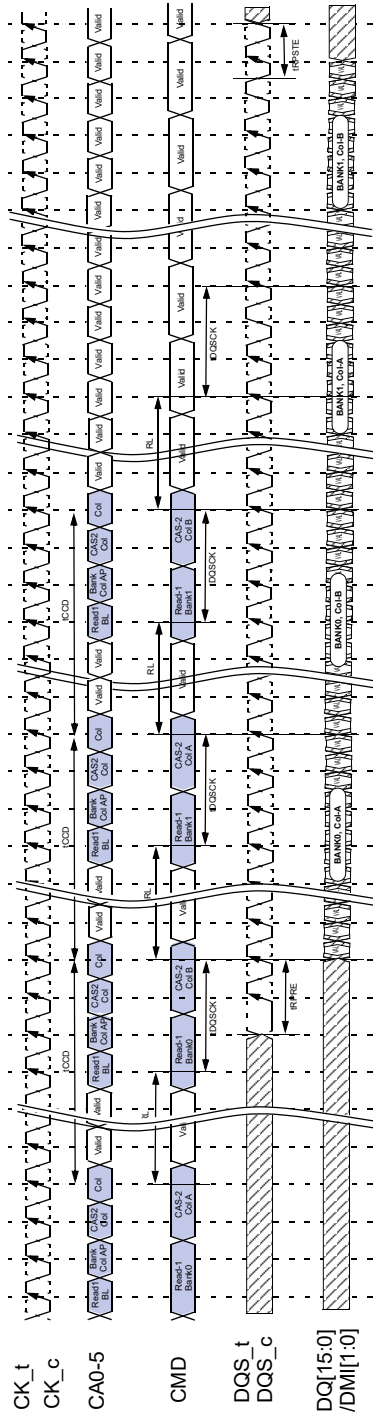
DQ ODT Disabled case; MR11 OP[2:0]=000b

$$t_{RTW} = RL + RU(t_{DQSC}(\max)/t_{CK}) + BL/2 - WL + t_{WPRES} + RD(t_{RPST})$$

DQ ODT Enabled case; MR11 OP[2:0]≠000b

$$t_{RTW} = RL + RU(t_{DQSK}(max)/t_{CK}) + BL/2 + RD(t_{RPST}) - ODT_{Lon} - RD(t_{ODT_{on},min}/t_{CK}) + 1$$

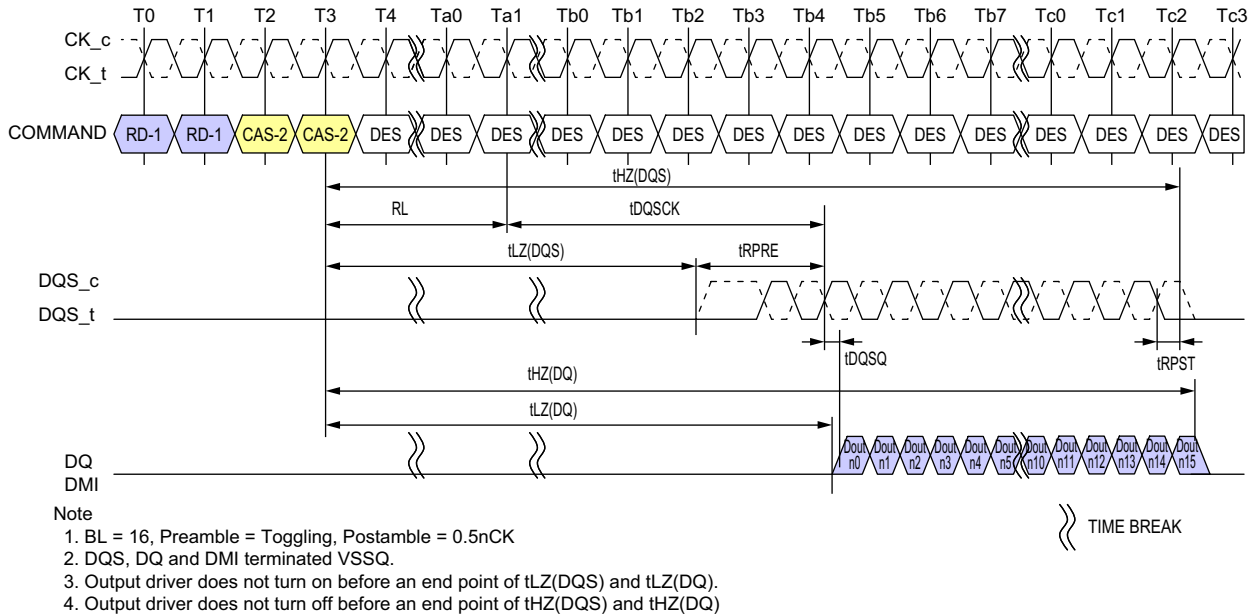
**Figure - Seamless Burst Read. BL=16, Toggling t<sub>RPRE</sub>, Extended t<sub>RPST</sub>**



The seamless Burst READ operation is supported by placing a READ command at every  $t_{CCD}(\min)$  interval for BL16 (or every  $2 \times t_{CCD}$  for BL32). The seamless Burst READ can access any open bank.

### 3.5. Read Timing

The read timing is shown in following figure:



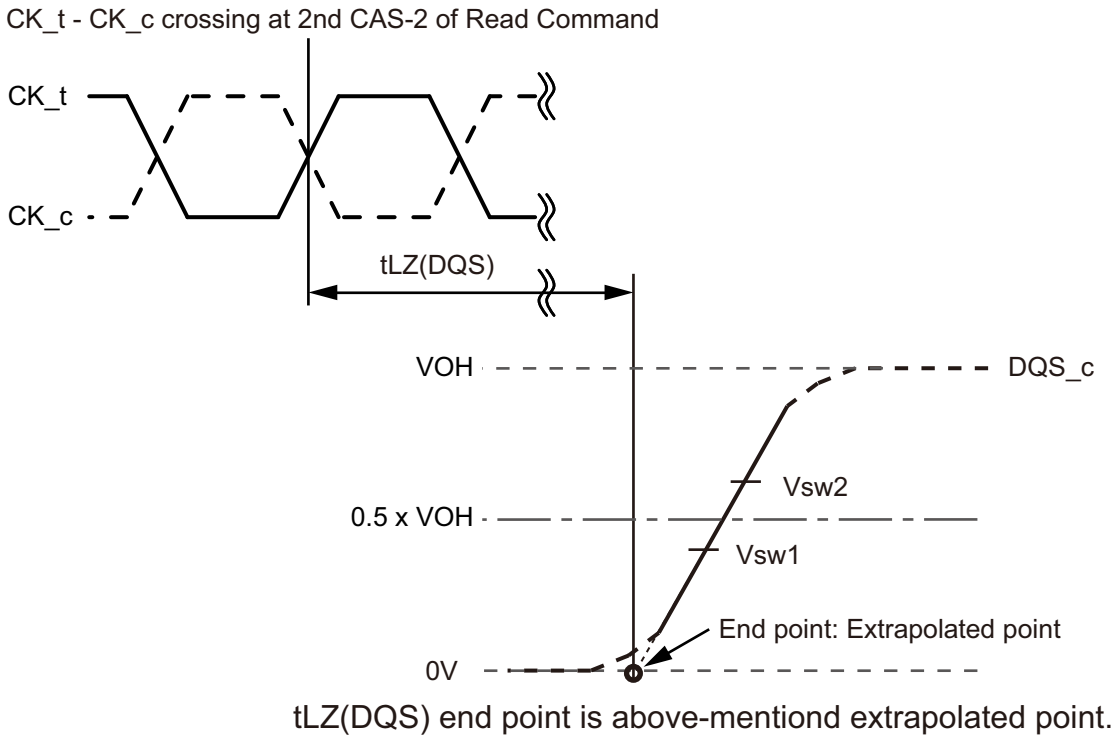
**Figure - Read Timing**

### 3.6. $t_{LZ}(DQS)$ , $t_{LZ}(DQ)$ , $t_{HZ}(DQS)$ , $t_{HZ}(DQ)$ Calculation

$t_{HZ}$  and  $t_{LZ}$  transitions occur in the same time window as valid data transitions. These parameters are referenced to a specific voltage level that specifies when the device output is no longer driving  $t_{HZ}(DQS)$  and  $t_{HZ}(DQ)$ , or begins driving  $t_{LZ}(DQS)$ ,  $t_{LZ}(DQ)$ .

This section shows a method to calculate the point when the device is no longer driving  $t_{HZ}(DQS)$  and  $t_{HZ}(DQ)$ , or begins driving  $t_{LZ}(DQS)$ ,  $t_{LZ}(DQ)$ , by measuring the signal at two different voltages. The actual voltage measurement points are not critical as long as the calculation is consistent. The parameters  $t_{LZ}(DQS)$ ,  $t_{LZ}(DQ)$ ,  $t_{HZ}(DQS)$ , and  $t_{HZ}(DQ)$  are defined as single ended.

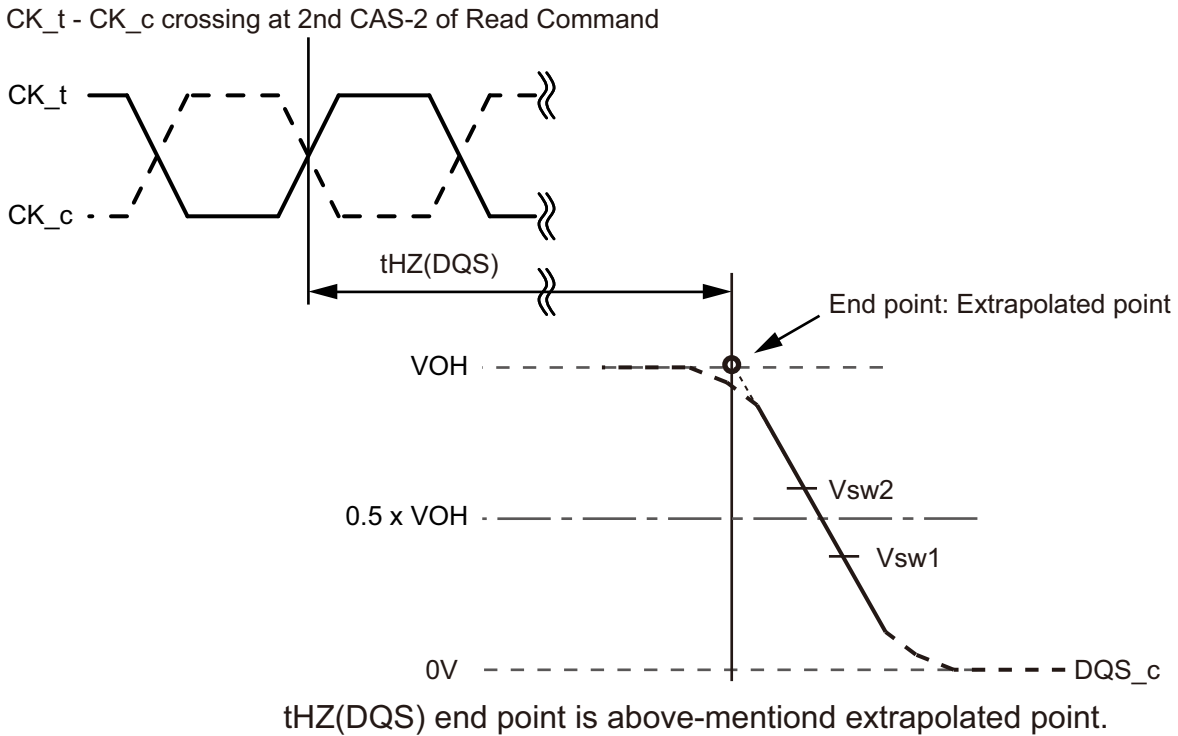
#### 3.6.1. $t_{LZ}(DQS)$ and $t_{HZ}(DQS)$ Calculation for ATE (Automatic Test Equipment)



Note

1. Conditions for Calibration: Pull Down Driver Ron = 40ohm, VOH = VDDQ/3
2. Termination condition for DQS\_t and DQS\_C = 50ohm to VSSQ.
3. The VOH level depends on MR22 OP[2:0] and MR3 OP[0] settings as well as device tolerances. Use the actual VOH value for tHZ and tLZ measurements.

**Figure - tLZ(DQS) method for calculating transitions and end point**



**Note**

1. Conditions for Calibration: Pull Down Driver Ron = 40ohm, VOH = VDDQ/3
2. Termination condition for DQS<sub>t</sub> and DQS<sub>c</sub> = 50ohm to VSSQ.
3. The VOH level depends on MR22 OP[2:0] and MR3 OP[0] settings as well as device tolerances. Use the actual VOH value for tHZ and tLZ measurements.

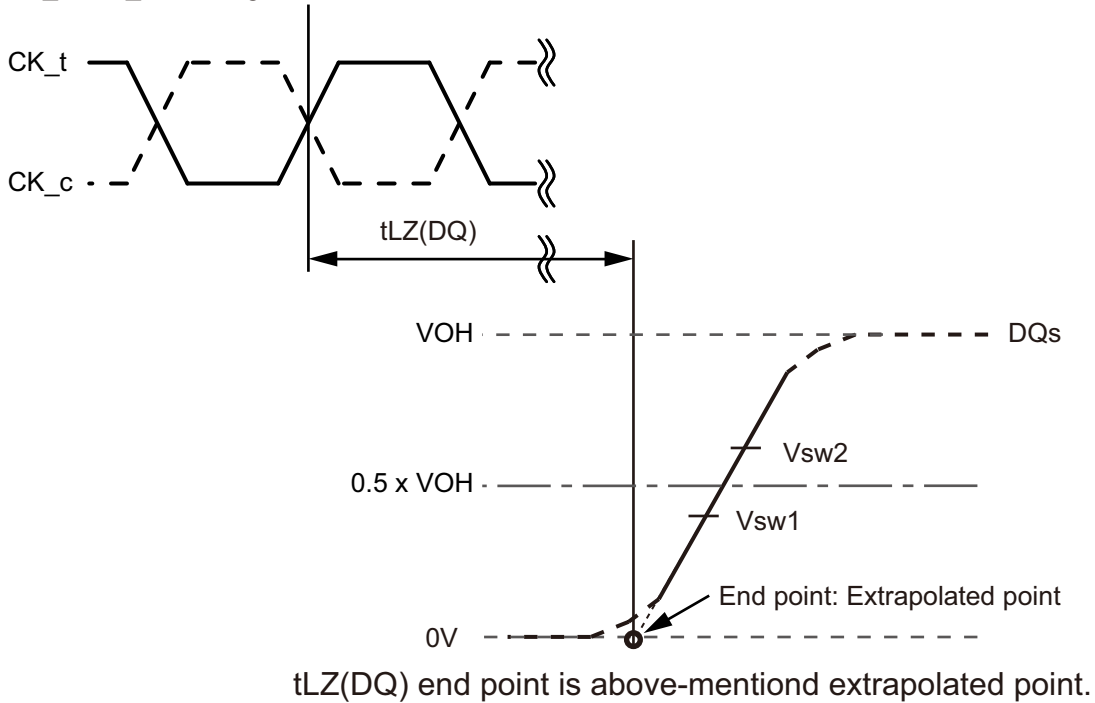
**Figure - tHZ(DQS) method for calculating transitions and end point**

**Table - Reference voltage for tLZ(DQS), tHZ(DQS) Timing Measurements**

Measured Parameter	Symbol	Vsw1 [V]	Vsw2 [V]
DQS <sub>c</sub> low-impedance time from CK <sub>t</sub> , CK <sub>c</sub>	tLZ(DQS)	0.4 x VOH	0.6 x VOH
DQS <sub>c</sub> high impedance time from CK <sub>t</sub> , CK <sub>c</sub>	tHZ(DQS)	0.4 x VOH	0.6 x VOH

### 3.6.2. tLZ(DQ) and tHZ(DQ) Calculation for ATE (Automatic Test Equipment)

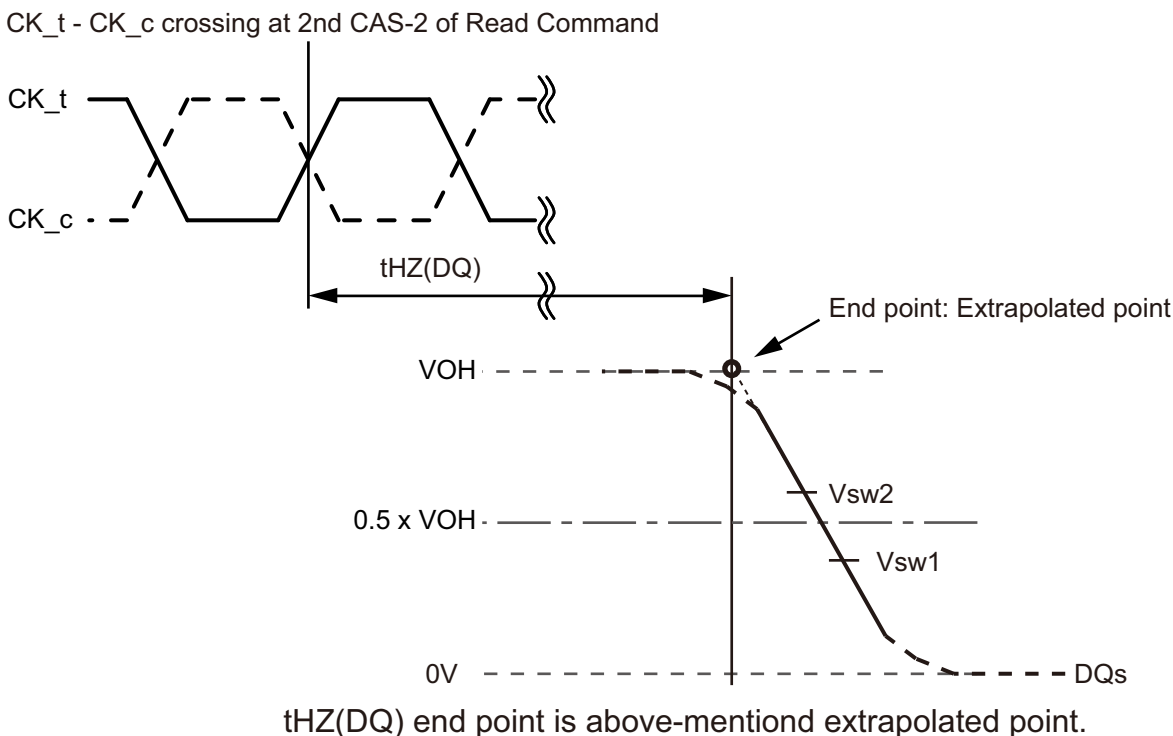
CK<sub>t</sub> - CK<sub>c</sub> crossing at 2nd CAS-2 of Read Command



**Note**

1. Conditions for Calibration: Pull Down Driver Ron = 40ohm, VOH = VDDQ/3
2. Termination condition for DQ and DMI = 50ohm to VSSQ.
3. The VOH level depends on MR22 OP[2:0] and MR3 OP[0] settings as well as device tolerances. Use the actual VOH value for tHZ and tLZ measurements.

**Figure - tLZ(DQ) method for calculating transitions and end point**



**Note**

1. Conditions for Calibration: Pull Down Driver Ron = 40ohm, VOH = VDDQ/3
2. Termination condition for DQ and DMI = 50ohm to VSSQ.
3. The VOH level depends on MR22 OP[2:0] and MR3 OP[0] settings as well as device tolerances. Use the actual VOH value for tHZ and tLZ measurements.

**Figure - tHZ(DQ) method for calculating transitions and end point**

**Table - Reference voltage for tLZ(DQS), tHZ(DQS) Timing Measurements**

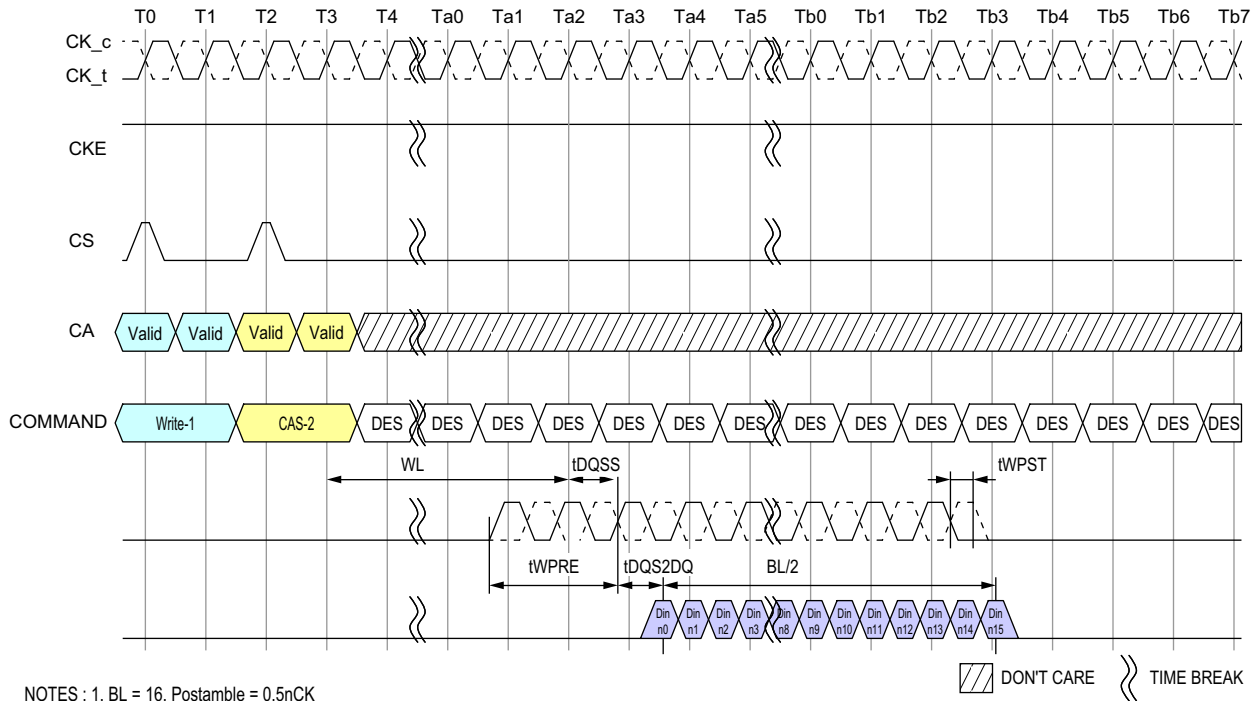
Measured Parameter	Symbol	Vsw1 [V]	Vsw2 [V]
DQ low-impedance time from CK <sub>t</sub> , CK <sub>c</sub>	tLZ(DQ)	0.4 x VOH	0.6 x VOH
DQ high impedance time from CK <sub>t</sub> , CK <sub>c</sub>	tHZ(DQ)	0.4 x VOH	0.6 x VOH

### 3.7. Write Preamble and Postamble

The DQS strobe for the LPDDR4-SDRAM requires a pre-amble prior to the first latching edge (the rising edge of DQS<sub>t</sub> with DATA "valid"), and it requires a post-amble after the last latching edge. The pre-amble and post-amble lengths are set via mode register writes (MRW).

For WRITE operations, a 2\*tCK pre-amble is required at all operating frequencies.

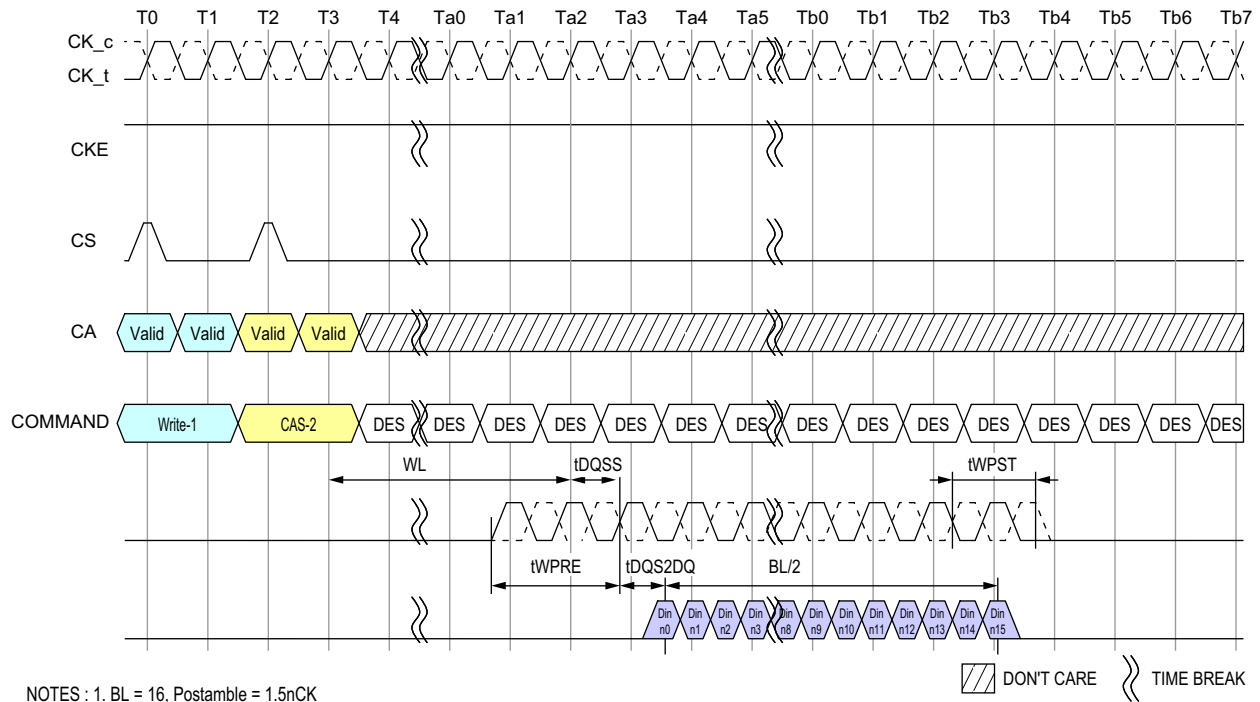
LPDDR4 will have a DQS Write post-amble of  $0.5 \cdot t_{CK}$  or extended to  $1.5 \cdot t_{CK}$ . Standard DQS post-amble will be  $0.5 \cdot t_{CK}$  driven by the memory controller for Writes. A mode register setting instructs the DRAM to drive an additional (extended) one cycle DQS Write post-amble. The drawings below show examples of DQS Write post-amble for both standard (tWPST) and extended (tWPSTE) post-amble operation.



- NOTES : 1. BL = 16, Postamble =  $0.5n_{CK}$   
 2. DQS and DQ terminated VSSQ  
 3. DQS\_t/DQS\_c is "don't care" prior to the start of tWPRE.  
 No transition of DQS is implied, as DQS\_t/DQS\_c can be HIGH, LOW, or HI-Z prior to tWPRE.

**Figure - DQS Write Preamble and Postamble;  $0.5n_{CK}$  Postamble**





**Figure - DQS Write Preamble and Postamble: 1.5nCK Postamble**

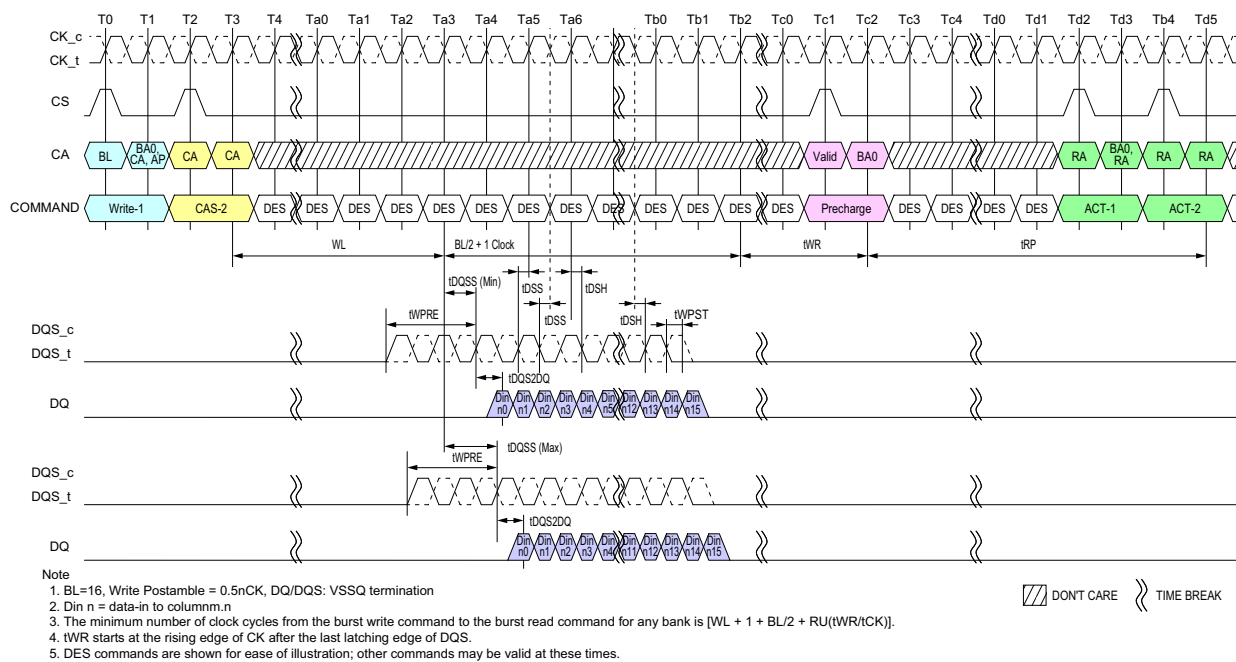
### 3.8. Burst Write Operation

A burst WRITE command is initiated with CKE, CS, and CA[5:0] asserted to the proper state at the rising edge of CK, as defined by the Command Truth Table. Column addresses C[3:2] should be driven LOW for Burst WRITE commands, and column addresses C[1:0] are not transmitted on the CA bus (and are assumed to be zero), so that the starting column burst address is always aligned with a 32B boundary. The write latency (WL) is defined from the last rising edge of the clock that completes a write command (Ex: the second rising edge of the CAS-2 command) to the rising edge of the clock from which tDQSS is measured. The first valid "latching" edge of DQS must be driven  $WL * tCK + tDQSS$  after the rising edge of Clock that completes a write command.

The LPDDR4-SDRAM uses an un-matched DQS-DQ path for lower power, so the DQS-strobe must arrive at

the SDRAM ball prior to the DQ signal by the amount of  $t_{DQS2DQ}$ . The DQS-strobe output is driven  $t_{WPRE}$  before the first valid rising strobe edge. The  $t_{WPRE}$ , write pre-ambler, is required to be  $2 \times t_{CK}$ . The DQS-strobe must be trained to arrive at the DQ pad center-aligned with the DQ-data. The DQ-data must be held for  $t_{DIVW}$  (data input valid window) and the DQS must be periodically trained to stay centered in the  $t_{DIVW}$  window to compensate for timing changes due to temperature and voltage variation. Burst data is captured by the SDRAM on successive edges of DQS until the 16 or 32 bit data burst is complete. The DQS-strobe must remain active (toggling) for  $t_{WPST}$  (WRITE post-ambler) after the completion of the burst WRITE. After a burst WRITE operation,  $t_{WR}$  must be satisfied before a PRECHARGE command to the same bank can be issued. Pin input timings are measured relative to the crosspoint of  $DQS\_t$  and  $DQS\_c$ .

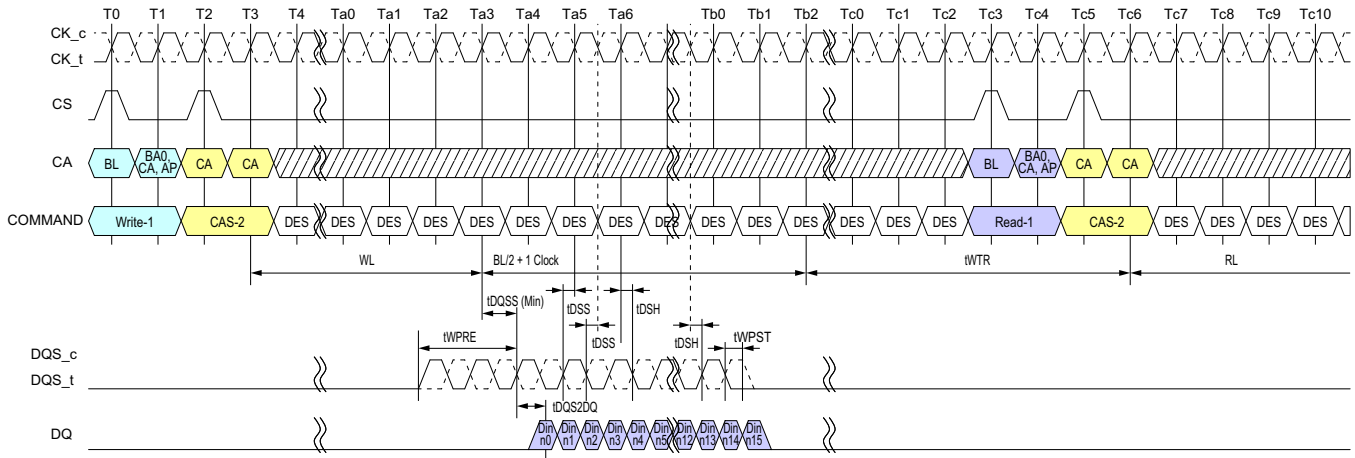
**Figure - Burst Write Operation**



**Notes**



1. BL=16, Write Postamble =  $0.5nCK$ , DQ/DQS: VSSQ termination
2. Din n = data-in to column.n
3. The minimum number of clock cycles from the burst write command to the precharge command for any bank is  $[WL + 1 + BL/2 + RU(t_{WR}/t_{CK})]$ .
4.  $t_{WR}$  starts at the rising edge of CK after the last latching edge of DQS.
5. DES commands are shown for ease of illustration; other commands may be valid at these times.

**Figure - Burst Write Followed by Burst Read**



**Note**

1. BL=16, Write Postamble = 0.5nCK, DQ/DQS: VSSQ termination
2. Din n = data-in to columnm.n
3. The minimum number of clock cycles from the burst write command to the burst read command for any bank is [WL + 1 + BL/2 + RU(tWTR/tCK)].
4. tWTR starts at the rising edge of CK after the last latching edge of DQS.
5. DES commands are shown for ease of illustration; other commands may be valid at these times.

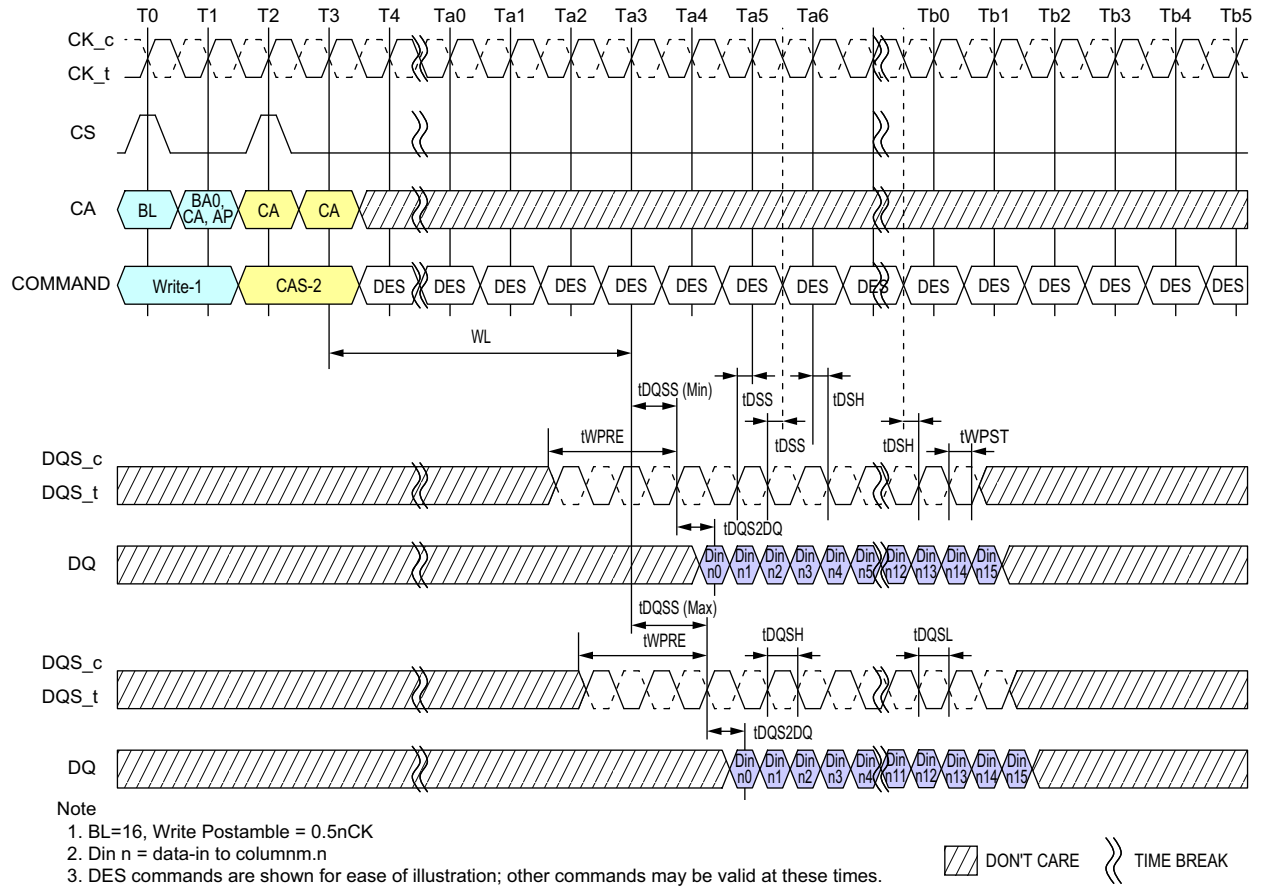
 DONT CARE     TIME BREAK

**Notes**

1. BL=16, Write Postamble = 0.5nCK, DQ/DQS: VSSQ termination
2. Din n = data-in to columnm.n
3. The minimum number of clock cycles from the burst write command to the burst read command for any bank is [WL + 1 + BL/2 + RU(tWTR/tCK)].
4. tWTR starts at the rising edge of CK after the last latching edge of DQS.
5. DES commands are shown for ease of illustration; other commands may be valid at these times.

**3.9. Write Timing**

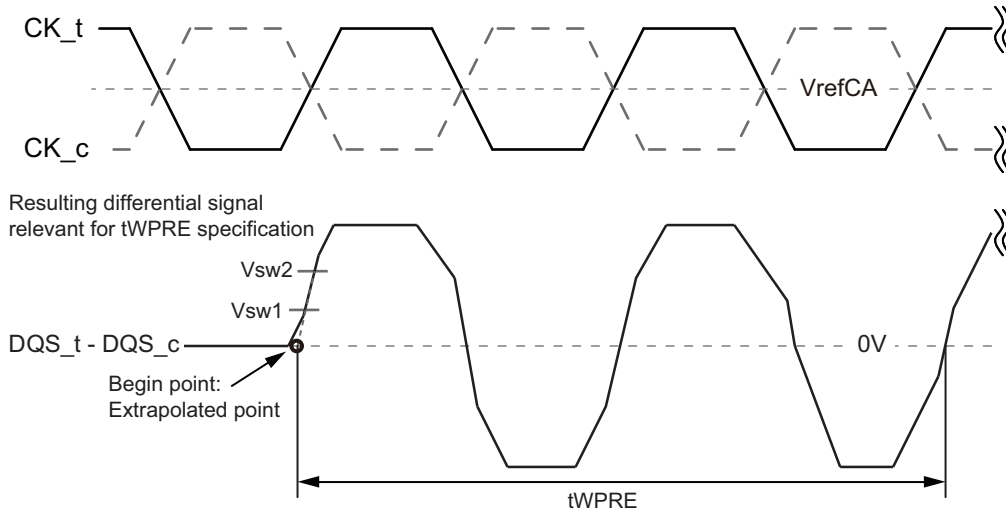
The write timing is shown in the following figure



**Figure - Write Timing**

### 3.9.1. tWPRE Calculation for ATE (Automated Test Equipment)

The method for calculating differential pulse widths for tWPRE is shown in the following figure



Note

1. Termination condition for DQS<sub>t</sub>, DQS<sub>c</sub>, DQ and DMI = 50ohm to VSSQ.

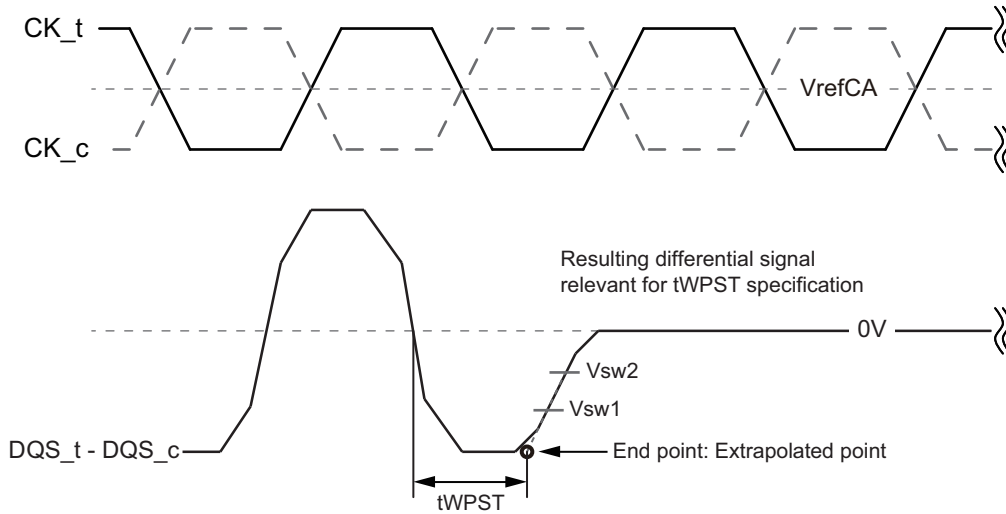
**Figure - Method for calculating tWPRE transitions and endpoints**

**Table - Reference Voltage for tWPRE Timing Measurements**

Measured Parameter	Symbol	Vsw1 [V]	Vsw2 [V]
DQS <sub>t</sub> , DQS <sub>c</sub> differential Write Preamble	tWPRE	VIHL <sub>AC</sub> x 0.3	VIHL <sub>AC</sub> x 0.7

### 3.9.2. tWPST Calculation for ATE (Automatic Test Equipment)

The method for calculating differential pulse widths for tWPST is shown in the following figure



**Note**

1. Termination condition for DQS\_t, DQS\_c, DQ and DMI = 50ohm to VSSQ.
2. Write Postamble: 0.5tCK
3. The method for calculating differential pulse widths for 1.5 tCK Postamble is same as 0.5 tCK Postamble.

**Figure - Method for calculating tWPST transitions and endpoints**

**Table - Reference Voltage for tWPST Timing Measurements**

Measured Parameter	Symbol	Vsw1 [V]	Vsw2 [V]
DQS_t, DQS_c differential Write Preamble	tWPST	- (VIHL_AC x 0.7)	- (VIHL_AC x 0.3)

### 3.10. Postamble and Preamble merging behavior

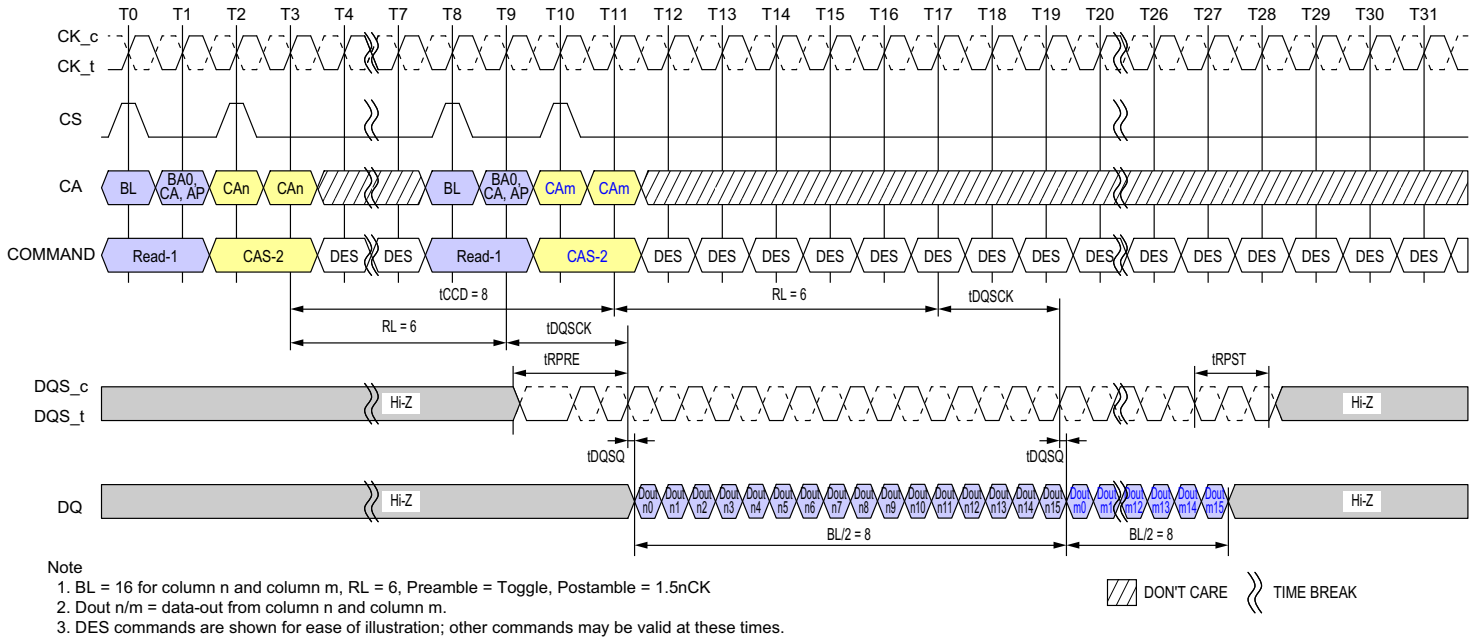
The DQS strobe for the device requires a preamble prior to the first latching edge (the rising edge of DQS\_t with data valid), and it requires a postamble after the last latching edge. The preamble and postamble options are set via Mode Register Write commands.

In Read to Read or Write to Write operations with tCCD=BL/2, postamble for 1st command and preamble for 2nd command will disappear to create consecutive DQS latching edge for seamless burst operations.

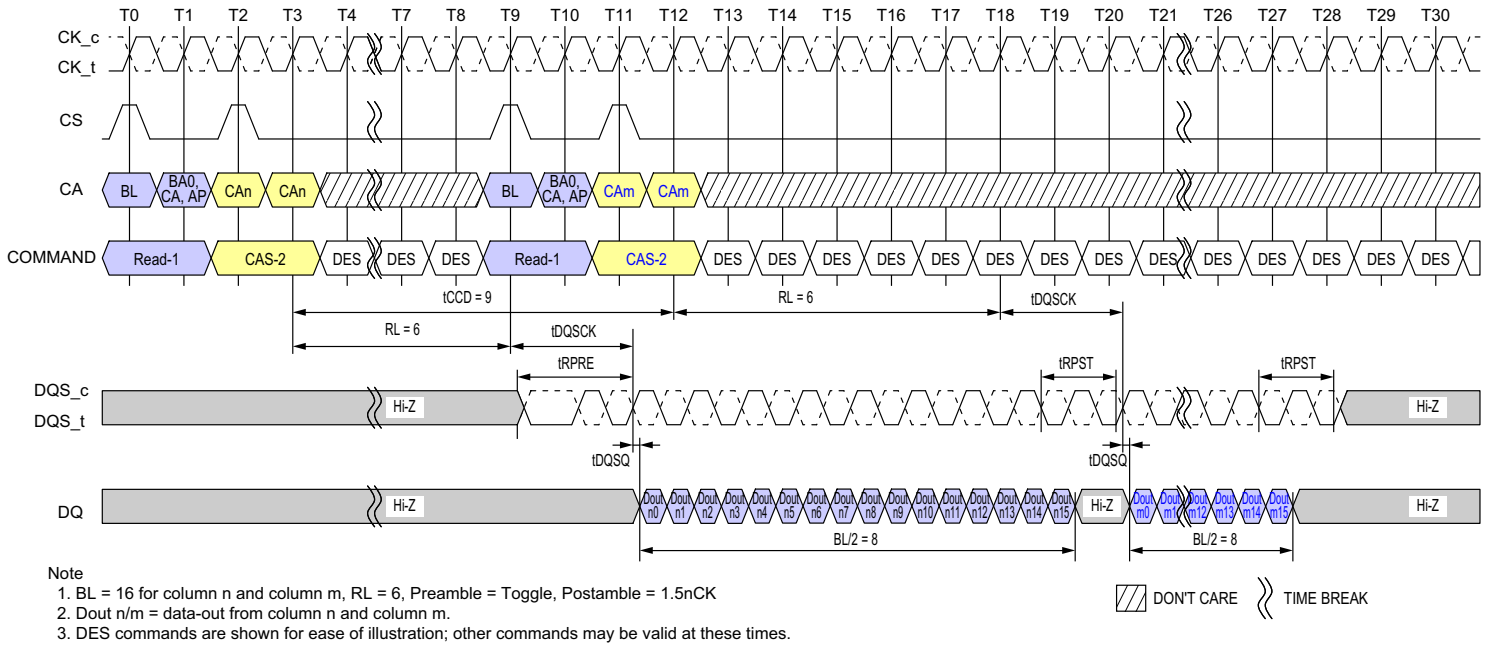
But in the case of Read to Read or Write to Write operations with command interval of tCCD+1, tCCD+2, etc., they will not completely disappear because it's not seamless burst operations.

Timing diagrams in this material describe Postamble and Preamble merging behavior in Read to Read or Write to Write operations with tCCD+n.

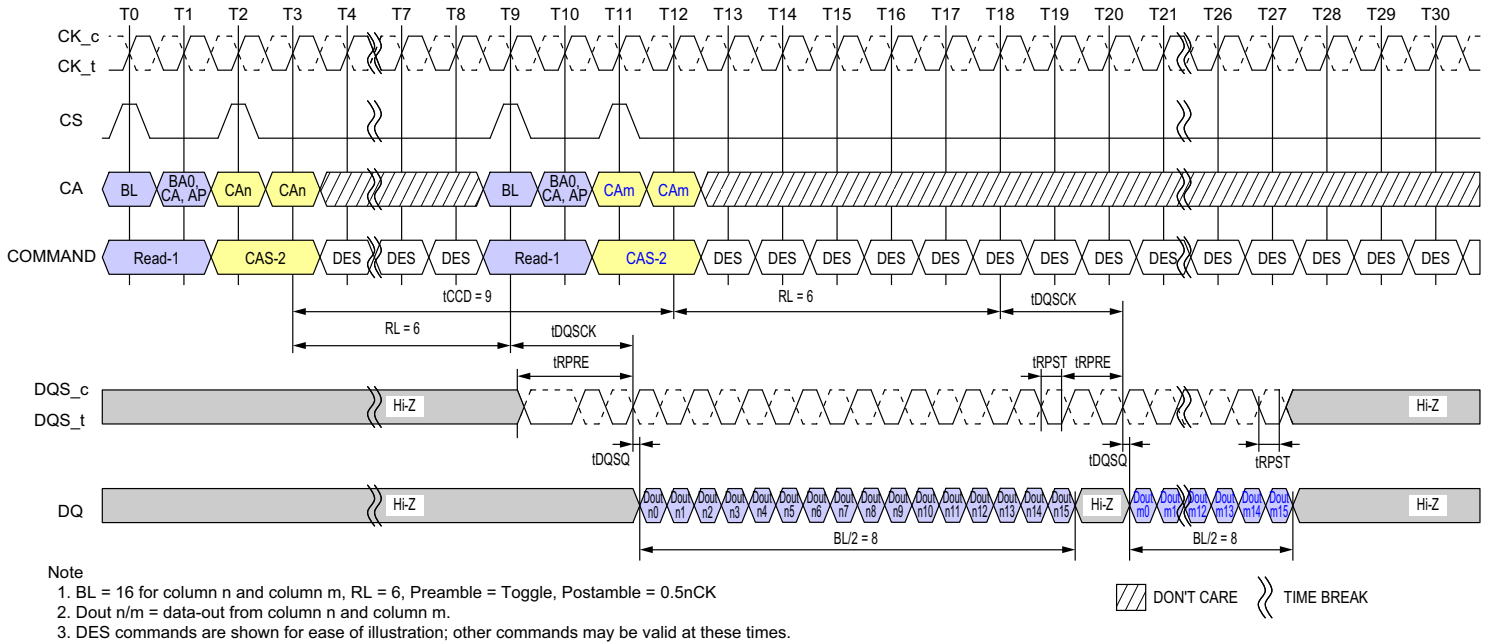
#### 3.10.1. Read to Read Operation



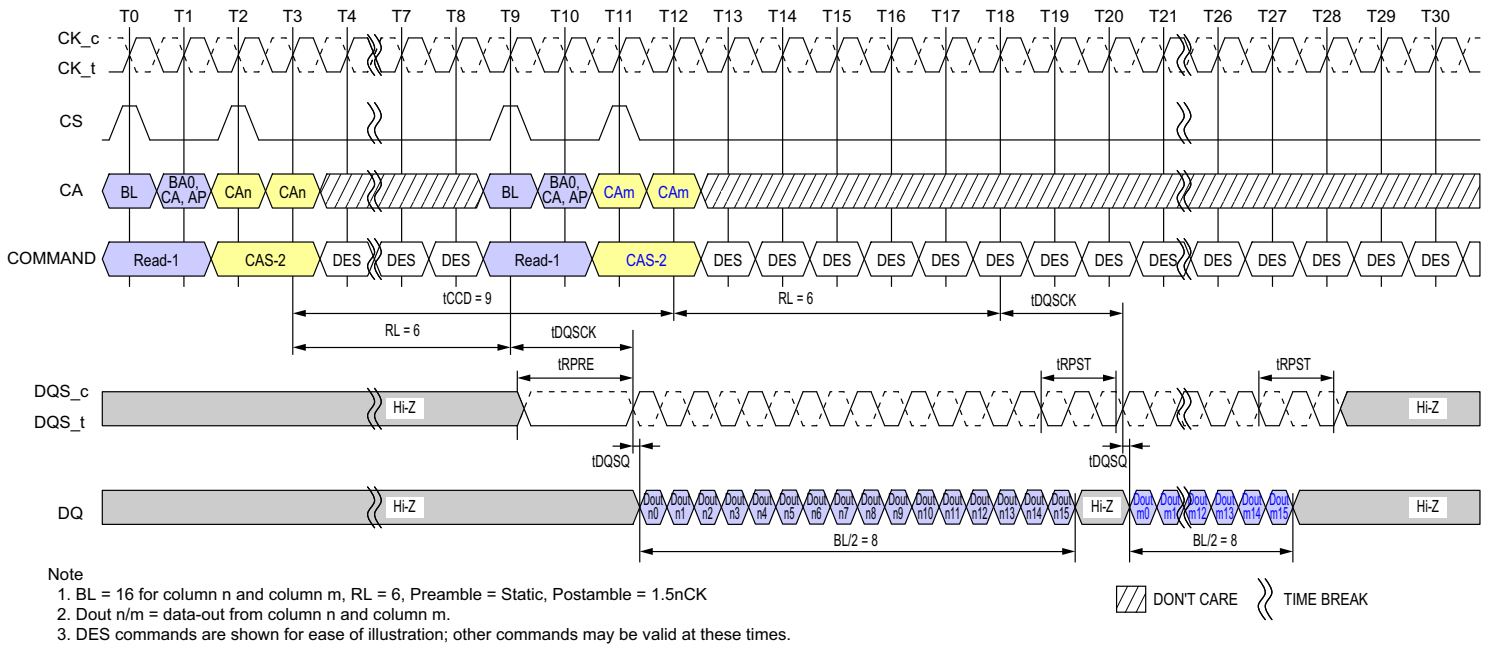
**Figure - Seamless Reads Operation: tCCD = Min, Preamble = Toggle, 1.5nCK Postamble**



**Figure - Consecutive Reads Operation: tCCD = Min+1, Preamble=Toggle, 1.5nCK Postamble**

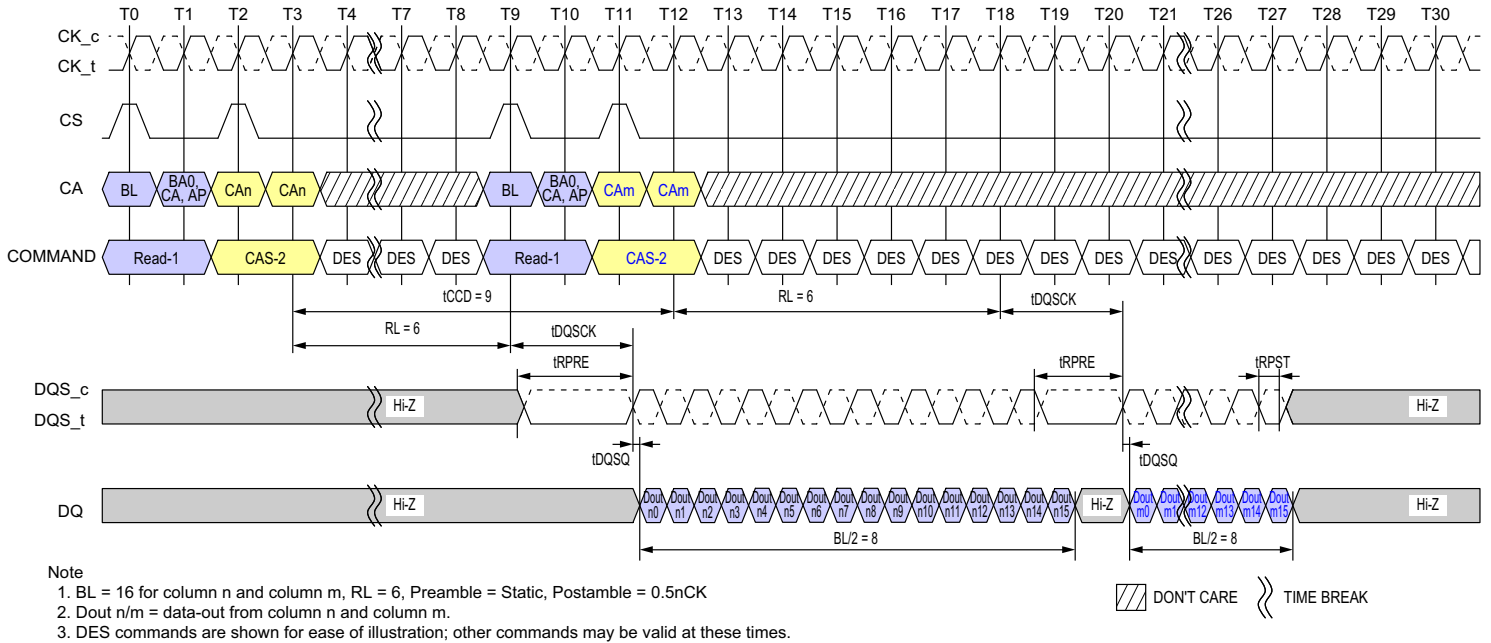


**Figure - Consecutive Reads Operation:  $t_{CCD} = \text{Min} + 1$ , Preamble = Toggle, 0.5nCK Postamble**

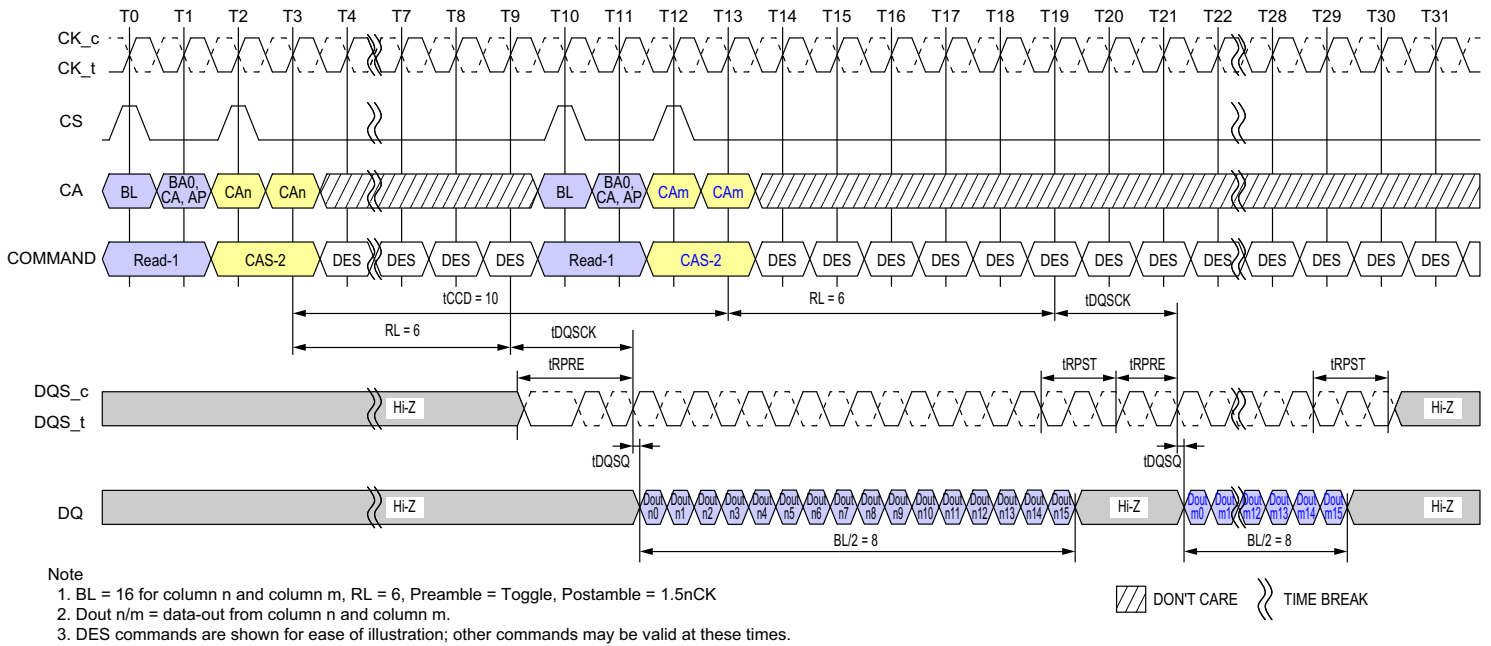


**Figure - Consecutive Reads Operation:  $t_{CCD} = \text{Min} + 1$ , Preamble = Static, 1.5nCK Postamble**

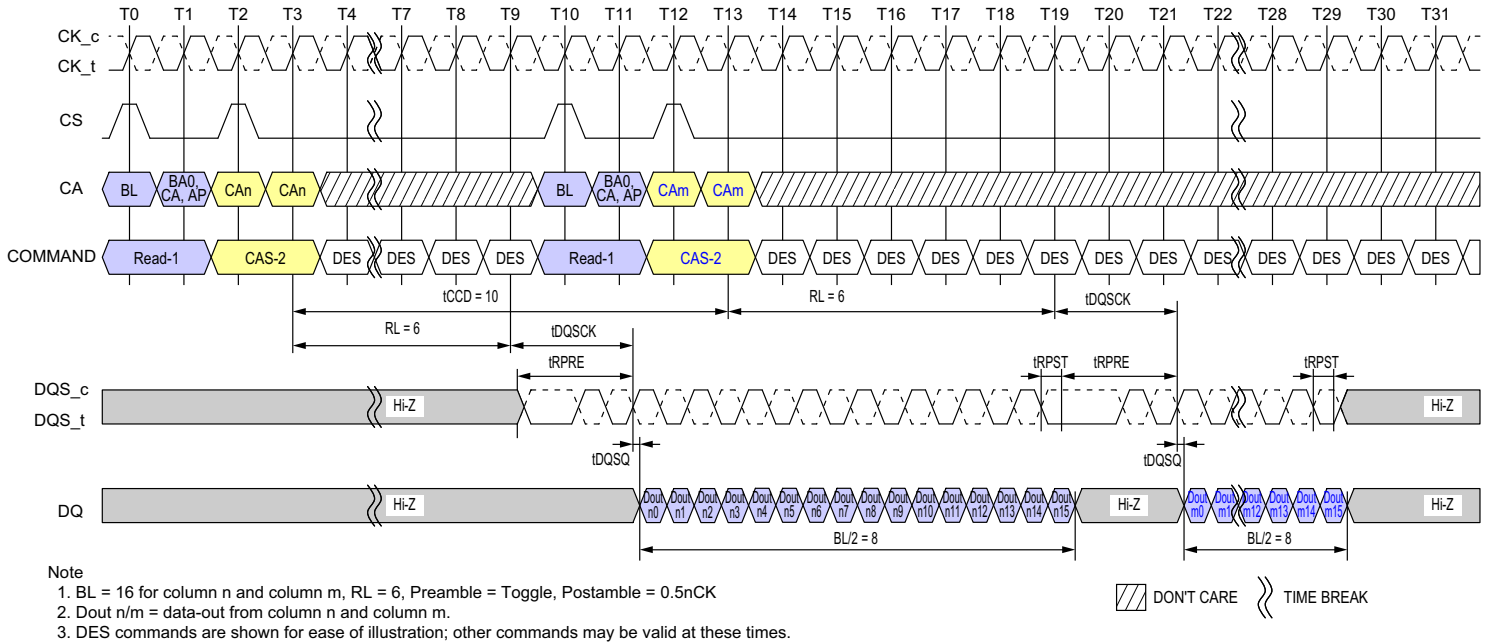




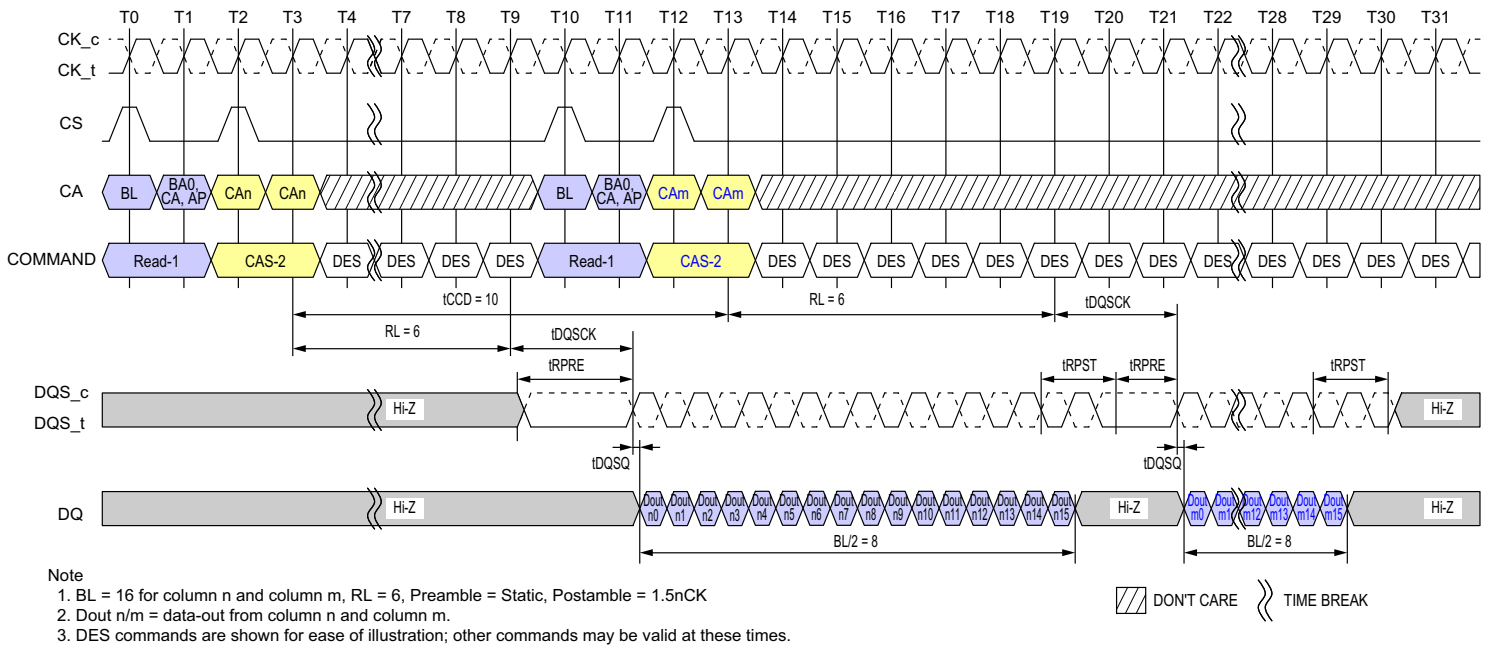
**Figure - Consecutive Reads Operation: tCCD = Min + 1, Preamble = Static, 0.5nCK Postamble**



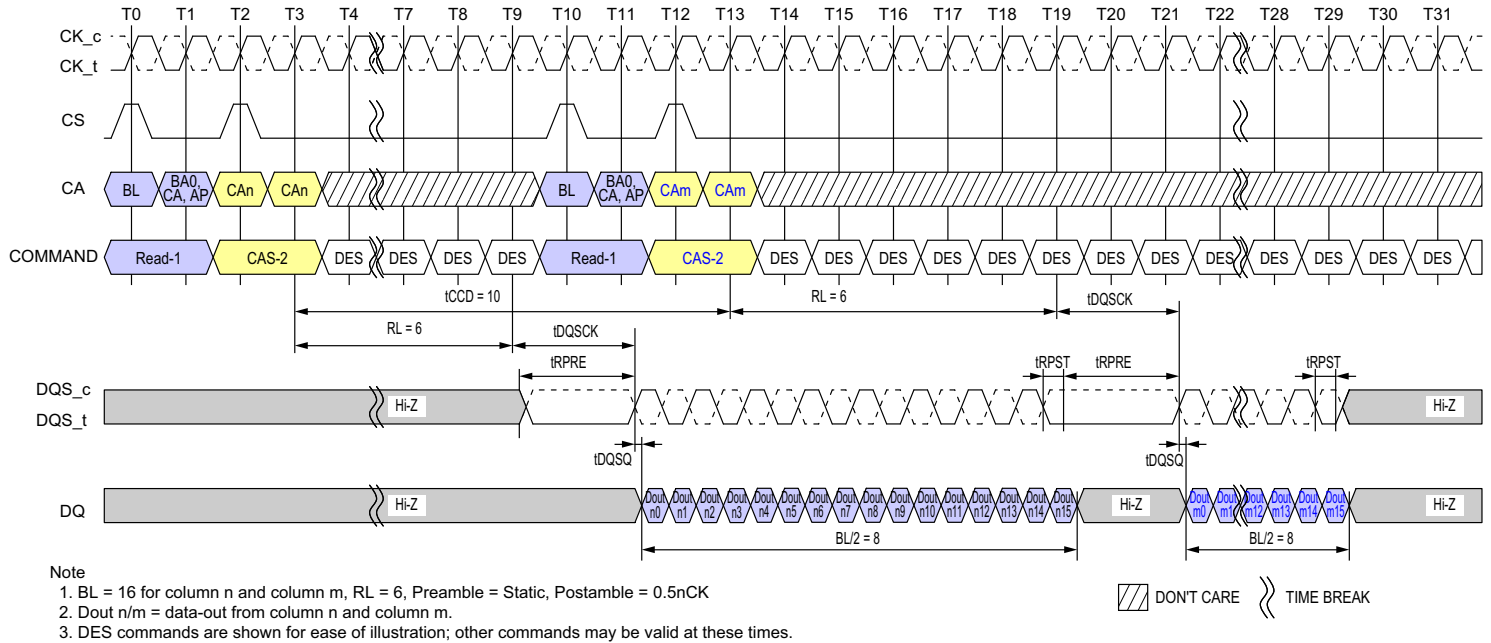
**Figure - Consecutive Reads Operation: tCCD = Min + 2, Preamble = Toggle, 1.5nCK Postamble**



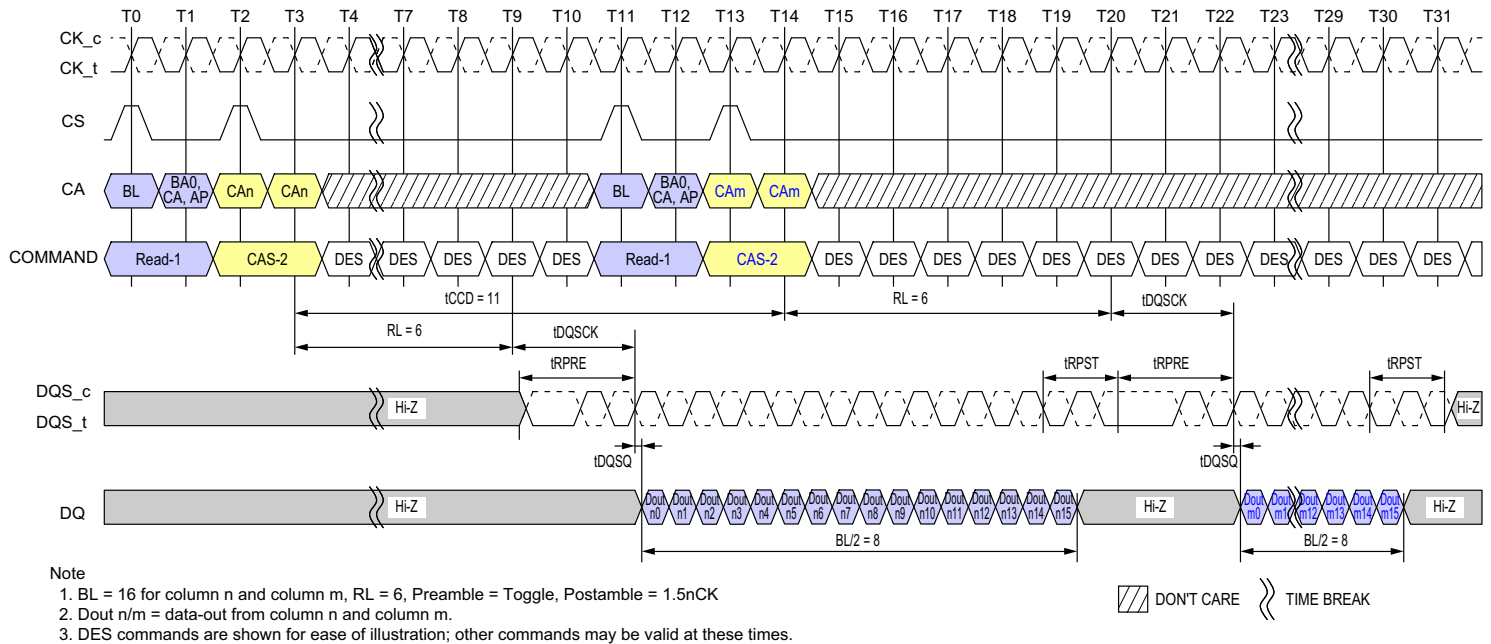
**Figure - Consecutive Reads Operation: tCCD = Min + 2, Preamble = Toggle, 0.5nCK Postamble**



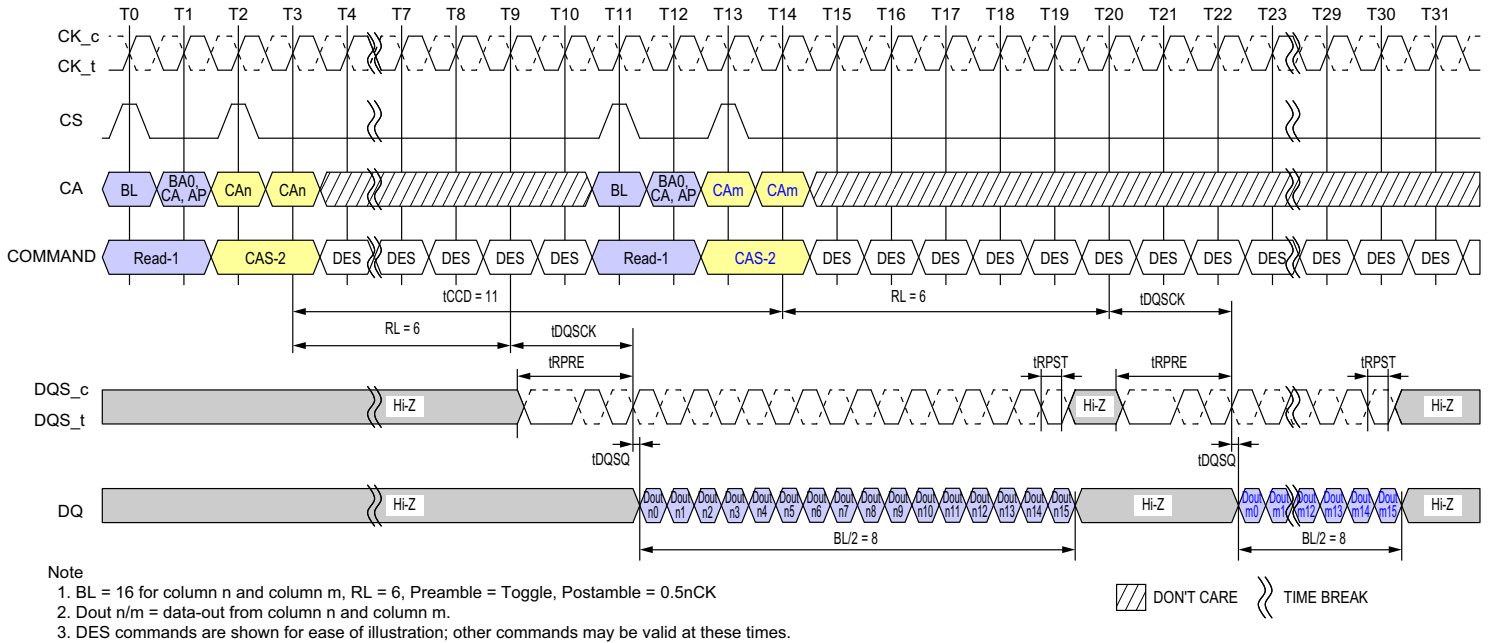
**Figure - Consecutive Reads Operation: tCCD = Min + 2, Preamble = Static, 1.5nCK Postamble**



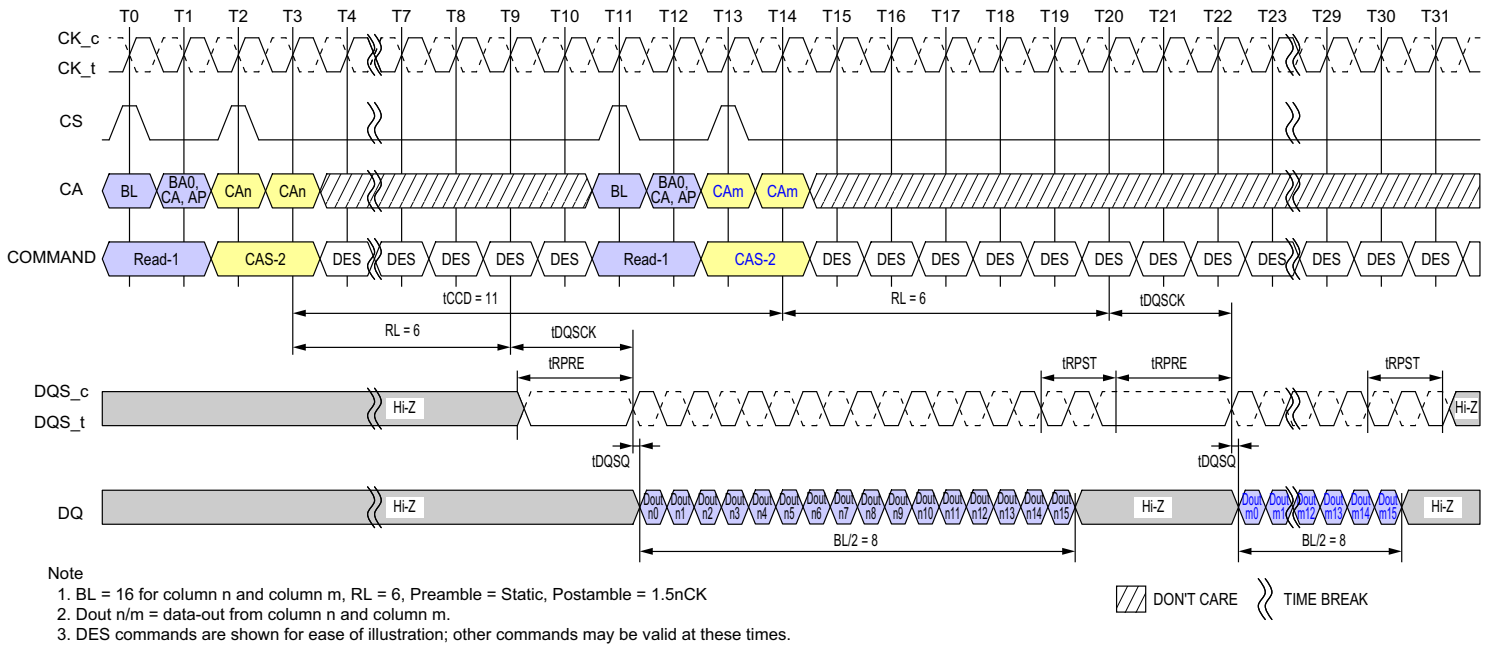
**Figure - Consecutive Reads Operation: tCCD = Min + 2, Preamble = Static, 0.5nCK Postamble**



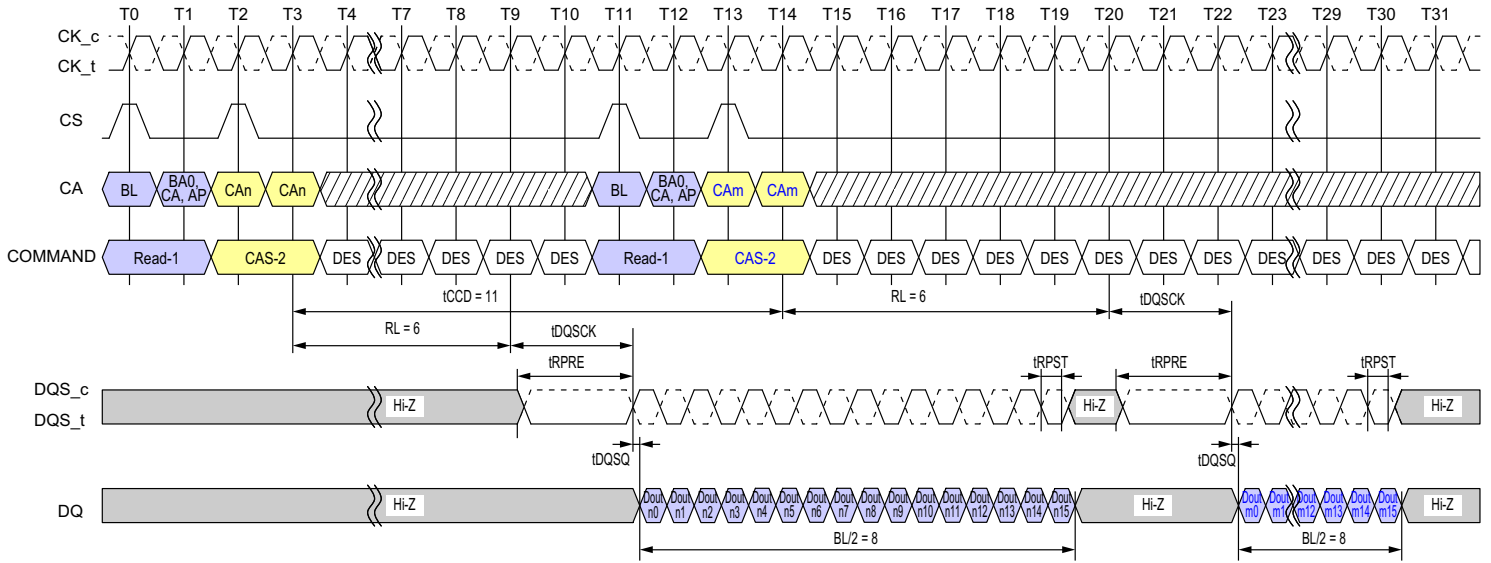
**Figure - Consecutive Reads Operation: tCCD = Min + 3, Preamble = Toggle, 1.5nCK Postamble**





**Figure - Consecutive Reads Operation: tCCD = Min +3, Preamble = Toggle, 0.5nCK Postamble**



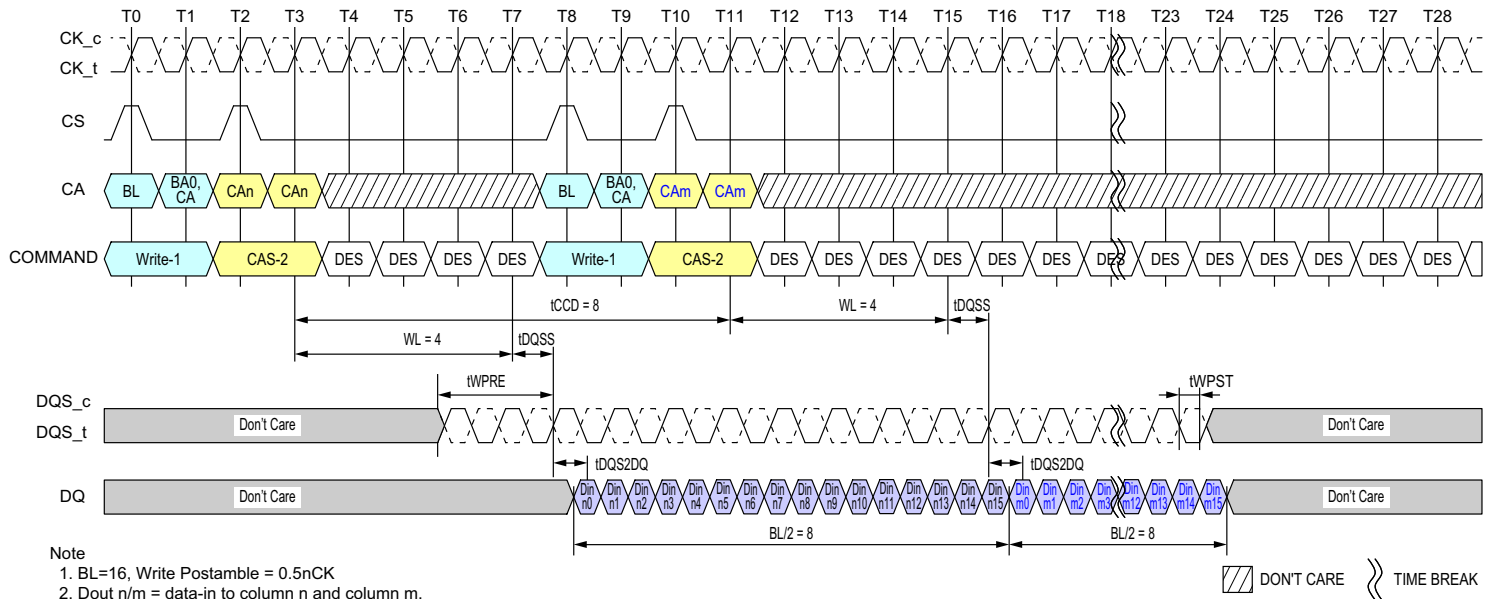
**Figure - Consecutive Reads Operation: tCCD = Min +3, Preamble = Static, 1.5nCK Postamble**



- Note
1. BL = 16 for column n and column m, RL = 6, Preamble = Static, Postamble = 0.5nCK
  2. Dout n/m = data-out from column n and column m.
  3. DES commands are shown for ease of illustration; other commands may be valid at these times.

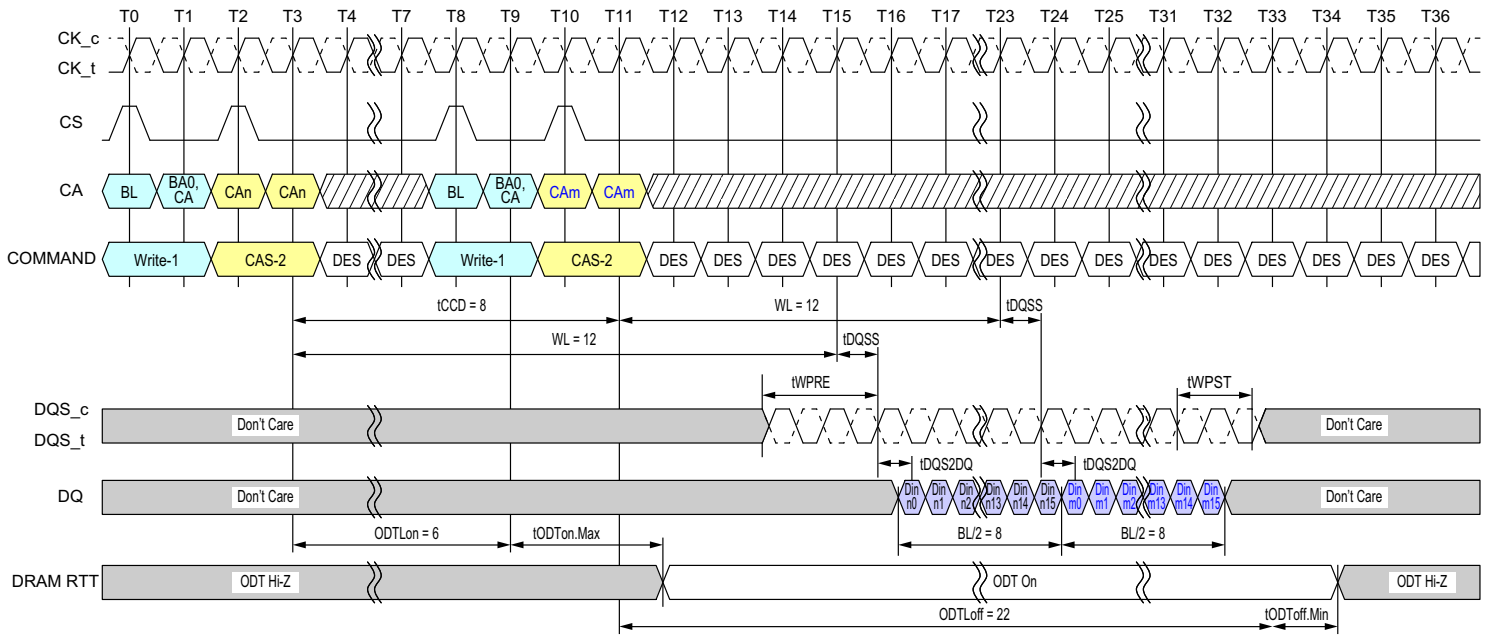
 DON'T CARE  TIME BREAK

**Figure - Consecutive Reads Operation: tCCD = Min +3, Preamble = Static, 0.5nCK Postamble**



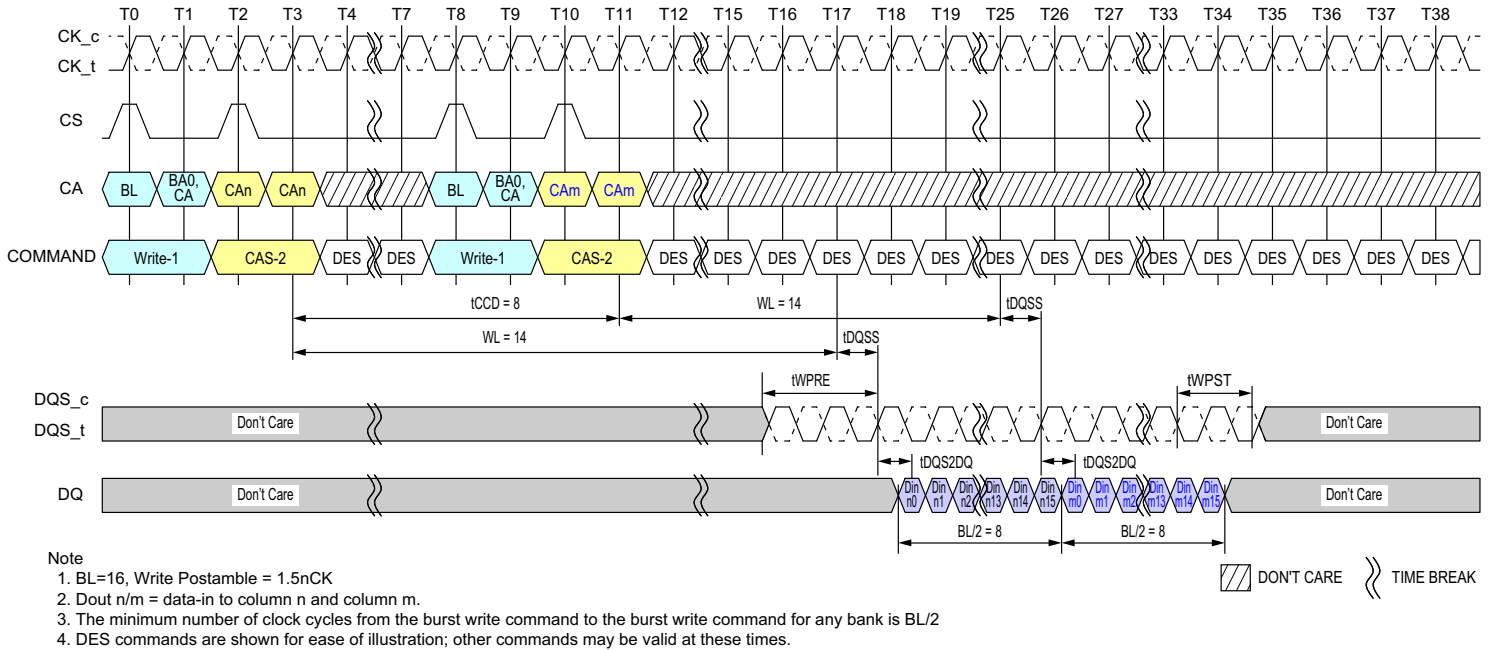
- Note
1. BL=16, Write Postamble = 0.5nCK
  2. Dout n/m = data-in to column n and column m.
  3. The minimum number of clock cycles from the burst write command to the burst write command for any bank is BL/2
  4. DES commands are shown for ease of illustration; other commands may be valid at these times.

**Figure - Seamless Writes Operation: tCCD = Min, 0.5nCK Postamble**

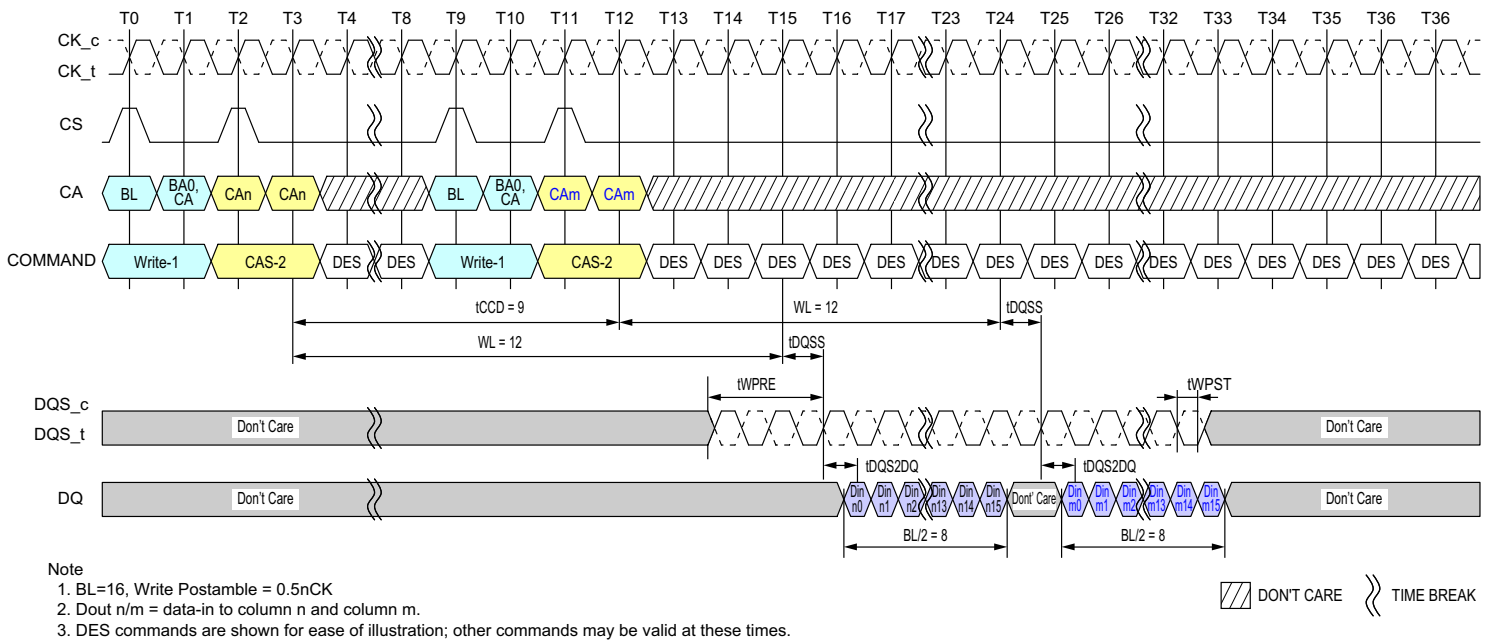


- Note
1. Clock Frequency = 800MHz,  $t_{CK(AVG)} = 1.25ns$
  2. BL=16, Write Postamble = 1.5nCK
  3. Dout n/m = data-in to column n and column m.
  3. The minimum number of clock cycles from the burst write command to the burst write command for any bank is BL/2
  4. DES commands are shown for ease of illustration; other commands may be valid at these times.
- DONT CARE   
 TIME BREAK

**Figure - Seamless Writes Operation:  $t_{CCD} = \text{Min}, 1.5nCK$  Postamble,  $533MHz < \text{Clock Freq.} \leq 800MHz$ , ODT Worst Timing Case**

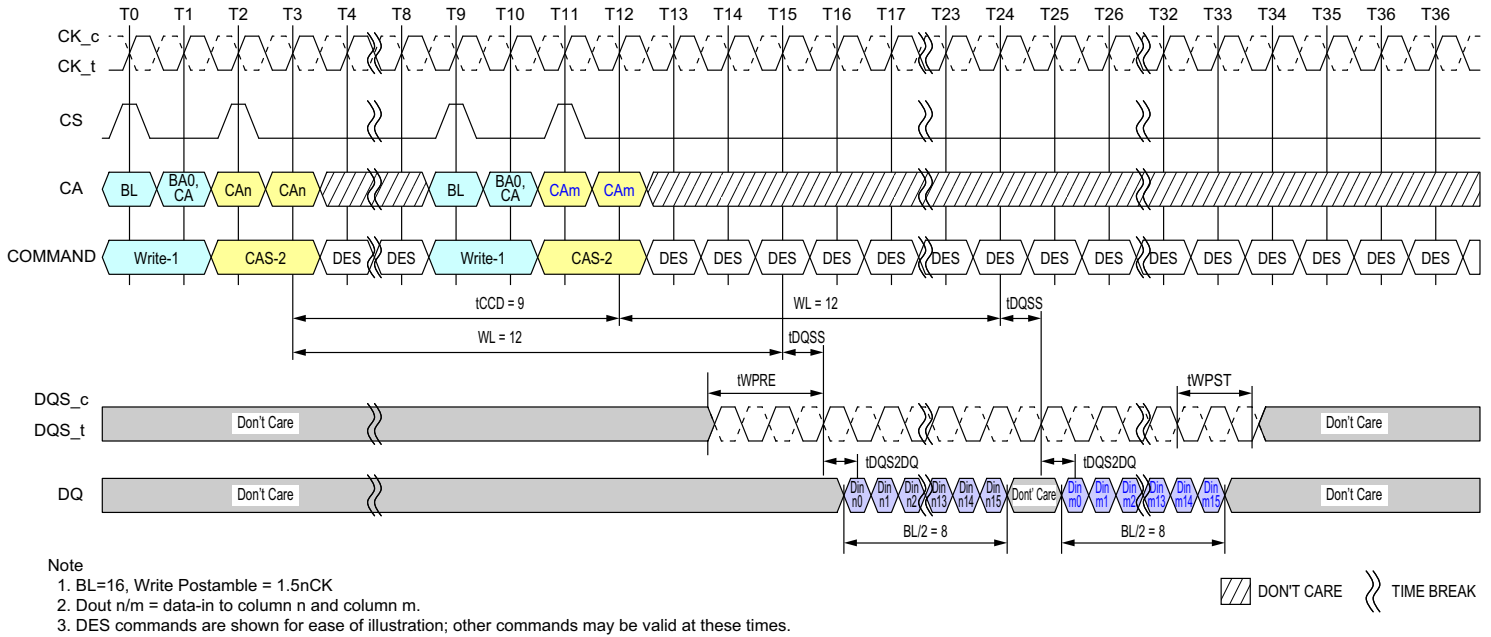


**Figure - Seamless Writes Operation: t<sub>CCD</sub> = Min, 1.5nCK Postamble**

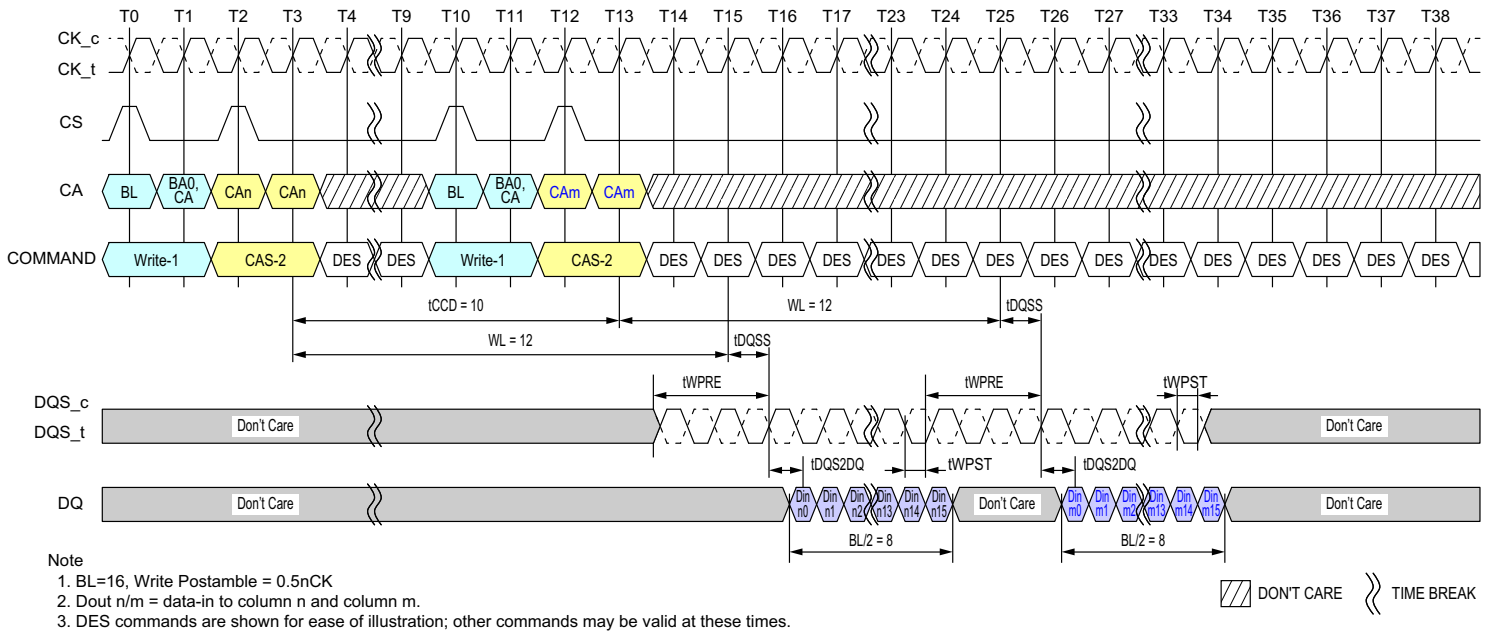


**Figure - Consecutive Writes Operation: t<sub>CCD</sub> = Min + 1, 0.5nCK Postamble**

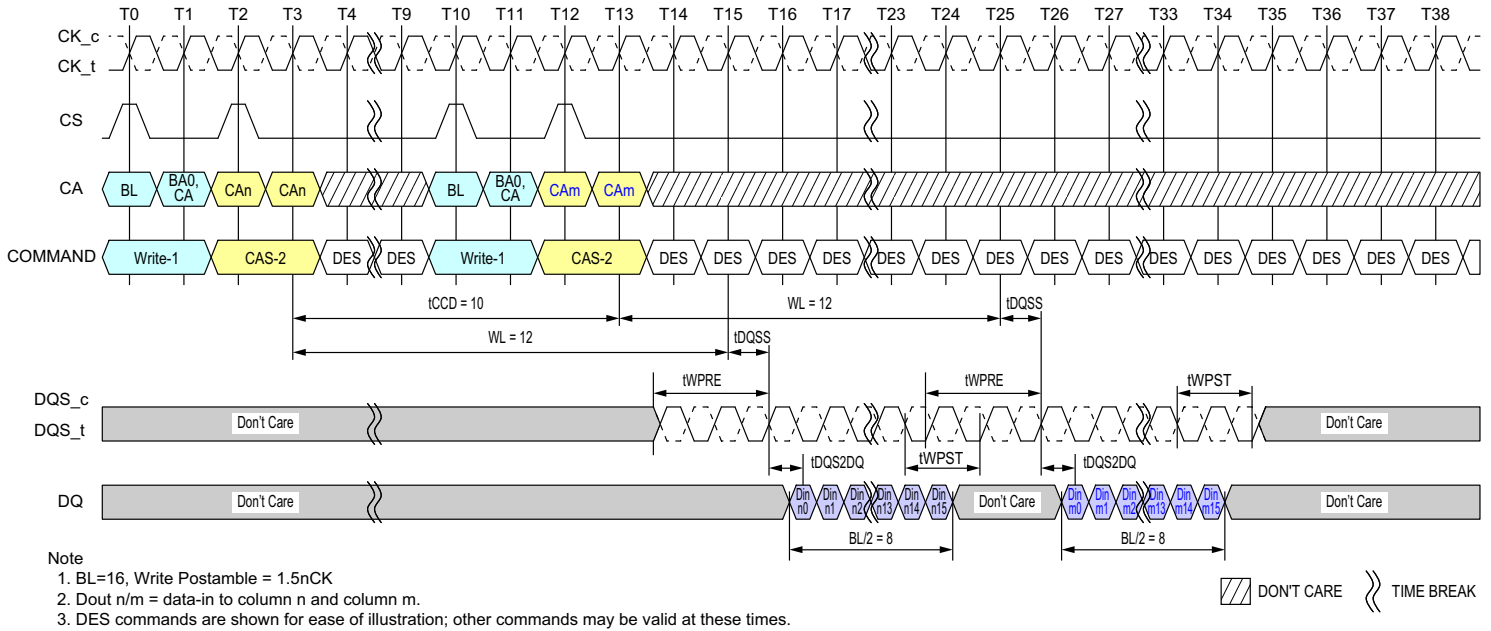




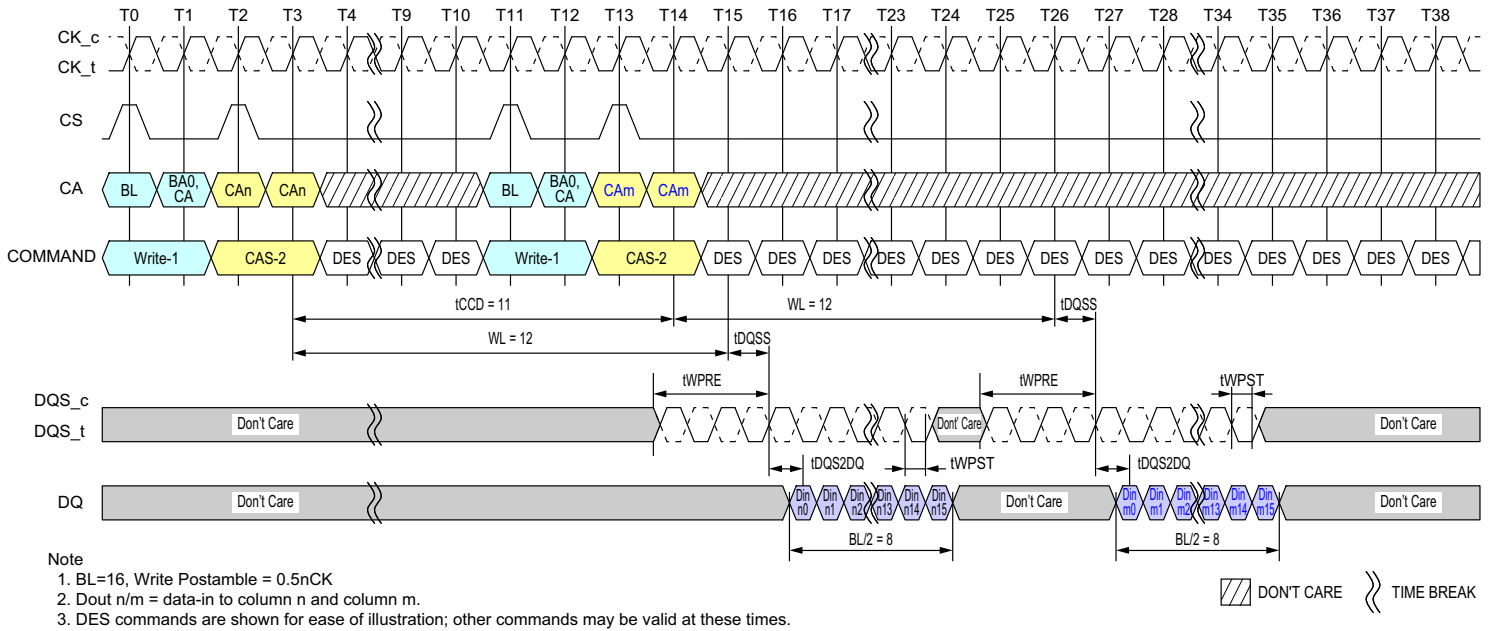
**Figure - Consecutive Writes Operation:  $t_{CCD} = \text{Min} + 1, 1.5n\text{CK}$  Postamble**



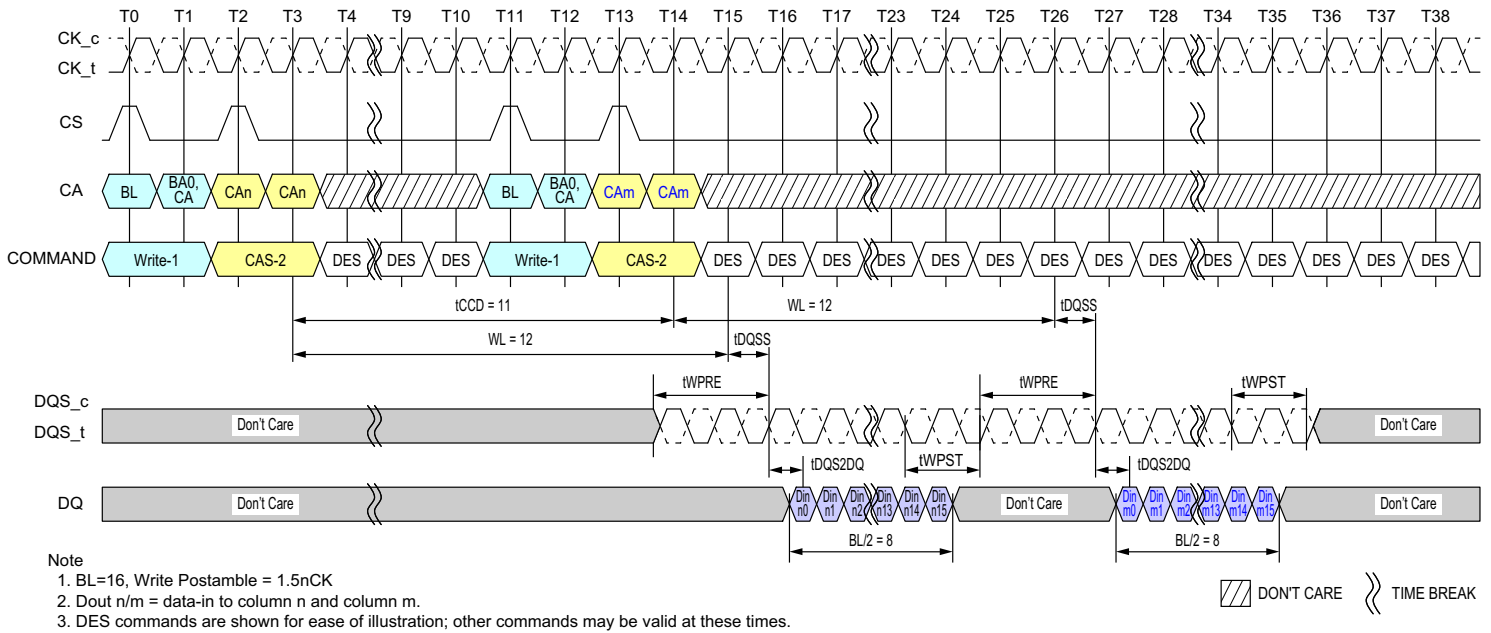
**Figure - Consecutive Writes Operation:  $t_{CCD} = \text{Min} + 2, 0.5n\text{CK}$  Postamble**



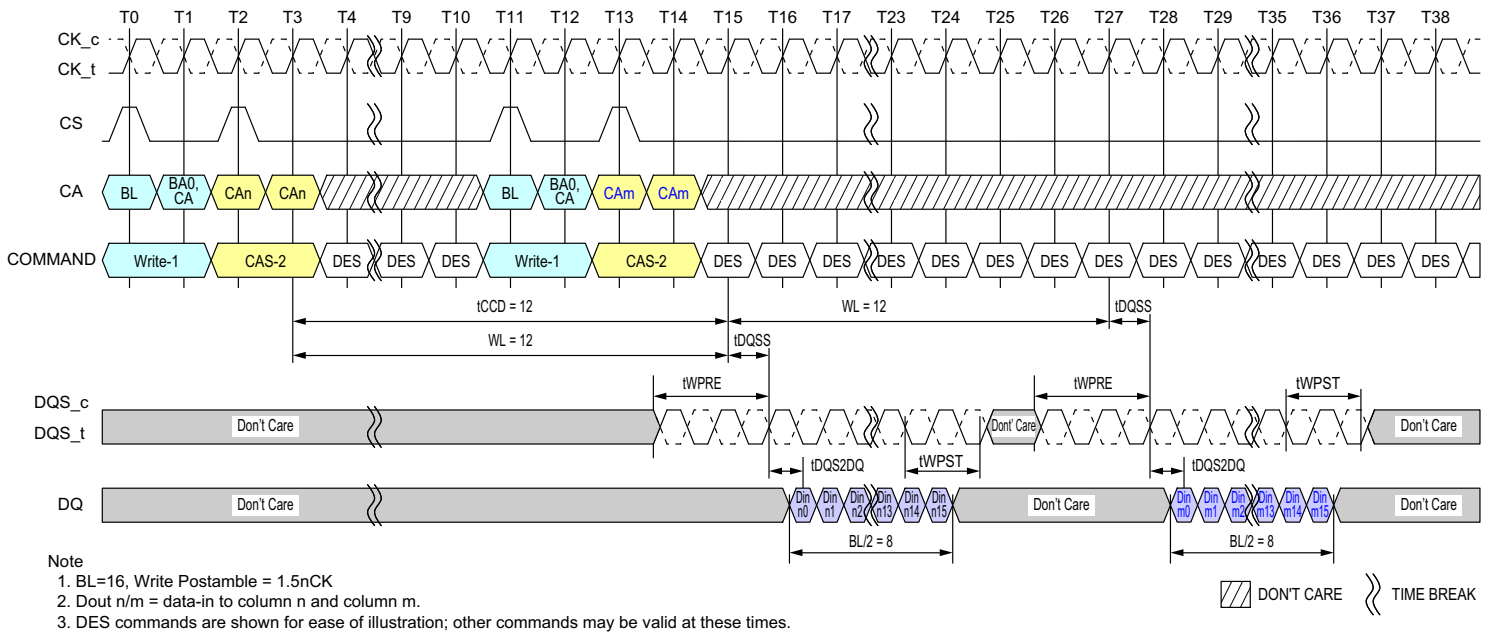
**Figure - Consecutive Writes Operation:  $t_{CCD} = Min + 2, 1.5nCK$  Postamble**



**Figure - Consecutive Writes Operation:  $t_{CCD} = Min + 3, 0.5nCK$  Postamble**



**Figure - Consecutive Writes Operation:  $t_{CCD} = Min + 3, 1.5nCK$  Postamble**



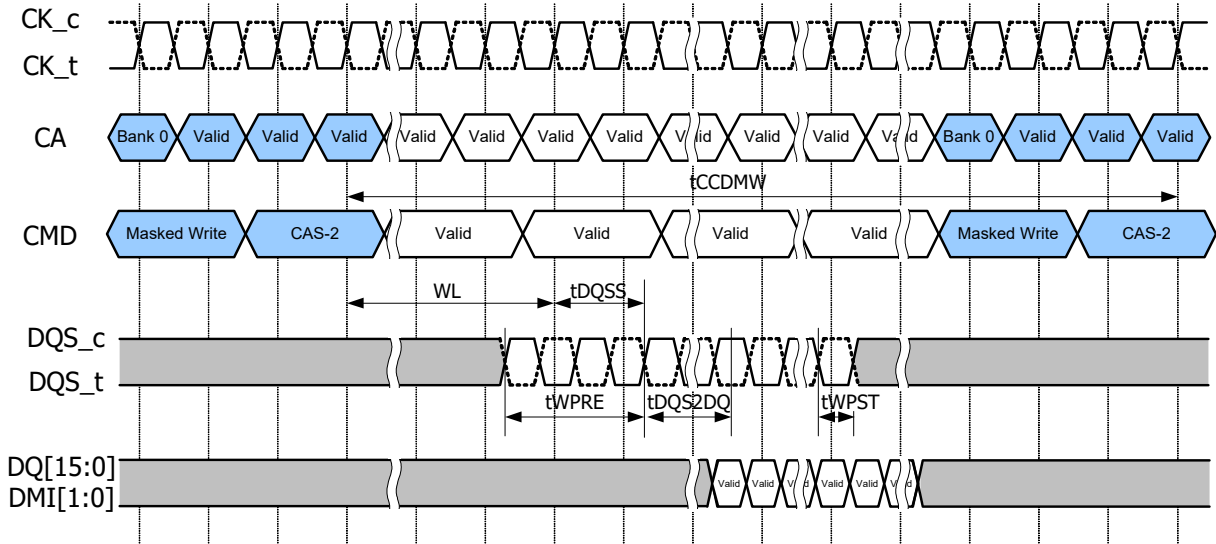
**Figure - Consecutive Writes Operation:  $t_{CCD} = Min + 4, 1.5nCK$  Postamble**

### 3.11. Masked Write Operation

The LPDDR4-SDRAM requires that Write operations which include a byte mask anywhere in the burst sequence must use the Masked Write command. This allows the DRAM to implement efficient data protection schemes based on larger data blocks. The Masked Write-1 command is used to begin the operation, followed by a CAS-2 command. A Masked Write command to the same bank cannot be issued until  $t_{CCDMW}$  is met, to allow the LPDDR4-SDRAM to finish the

internal Read-Modify-Write. One Data Mask-Invert (DMI) pin is provided per byte lane, and the Data Mask-Invert timings match data bit (DQ) timing. See the section on "Data Mask Invert" for more information on the use of the DMI signal.

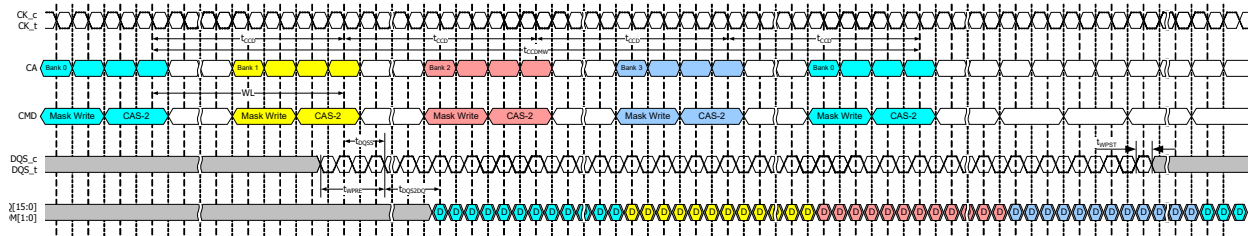
**Figure - Masked Write Command - Same Bank (Shown with BL16, 2tCK Preamble)**



**Notes:**

1. Masked Write supports only BL16 operations. For BL32 configuration, the system needs to insert only 16 bit wide data for masked write operation.

**Figure - Masked Write Command - Different Bank (shown with BL16, 2tCK Preamble)**



**Notes:**

1. Masked Write supports only BL16 operations. For BL32 configuration, the system needs to insert only 16 bit wide data for masked write operation.

### 3.11.1. Masked Write Timing constraints

**Table - Masked Write Timing constraints - Same bank**

Next CMD Current CMD	Activate	Read (BL16 or 32)	Write (BL16 or 32)	Masked Write	Precharge
Activate	Illegal	RU(tRCD/tCK)	RU(tRCD/tCK)	RU(tRCD/tCK)	RU(tRAS/tCK)
Read (BL16)	Illegal	8 <sup>1)</sup>	RL+RU(tDQSCCK(max)/tCK) +BL/2- WL+tWPRE+tRPST	RL+RU(tDQSCCK(max)/tCK) +BL/2- WL+tWPRE+tRPST	BL/2+max{(8,RU(tRTP/tCK))-8}
Read (BL32)	Illegal	16 <sup>2)</sup>	RL+RU(tDQSCCK(max)/tCK) +BL/2- WL+tWPRE+tRPST	RL+RU(tDQSCCK(max)/tCK) +BL/2- WL+tWPRE+tRPST	BL/2+max{(8,RU(tRTP/tCK))-8}
Write (BL16)	Illegal	WL+1+BL/2 +RU(tWTR/tCK)	8 <sup>1)</sup>	tCCDMW <sup>3)</sup>	WL+ 1 + BL/2 +RU(tWR/tCK)
Write (BL32)	Illegal	WL+1+BL/2 +RU(tWTR/tCK)	16 <sup>2)</sup>	tCCDMW + 8 <sup>4)</sup>	WL+ 1 + BL/2 +RU(tWR/tCK)
Masked Write	Illegal	WL+1+BL/2 +RU(tWTR/tCK)	tCCD	tCCDMW <sup>3)</sup>	WL+ 1 + BL/2 +RU(tWR/tCK)
Precharge	RU(tRP/tCK), RU(tRPab/tCK)	Illegal	Illegal	Illegal	4

Notes:

- 1) In the case of BL = 16, tCCD is 8\*tCK.
- 2) In the case of BL = 32, tCCD is 16\*tCK.
- 3) tCCDMW = 32\*tCK (4\*tCCD at BL=16)
- 4) Write with BL=32 operation has 8\*tCK longer than BL =16.
- 5) Units : tCK

**Table - Masked Write Timing constraints - Different bank**

Next CMD Current CMD	Activate	Read (BL16 or 32)	Write (BL16 or 32)	Masked Write (BL16)	Precharge
Activate	RU(tRRD/tCK)	4	4	4	2
Read (BL16)	4	8 <sup>1)</sup>	RL+RU(tDQSCCK(max)/tCK) +BL/2- WL+tWPRE+tRPST	RL+RU(tDQSCCK(max)/tCK) +BL/2- WL+tWPRE+tRPST	2
Read (BL32)	4	16 <sup>1)</sup>	RL+RU(tDQSCCK(max)/tCK) +BL/2- WL+tWPRE+tRPST	RL+RU(tDQSCCK(max)/tCK) +BL/2- WL+tWPRE+tRPST	2
Write (BL16)	4	WL+1+BL/2 +RU(tWTR/tCK)	8 <sup>1)</sup>	8 <sup>1)</sup>	2
Write (BL32)	4	WL+1+BL/2 +RU(tWTR/tCK)	16 <sup>1)</sup>	16 <sup>1)</sup>	2
Masked Write	4	WL+1+BL/2 +RU(tWTR/tCK)	8 <sup>1)</sup>	8 <sup>1)</sup>	2
Precharge	4	4	4	4	4

Notes:

- 1) In the case of BL = 16, tCCD is 8\*tCK.
- 2) In the case of BL = 32, tCCD is 16\*tCK.
- 3) Units : tCK

### 3.12. LPDDR4 Data Mask (DM) and Data Bus Inversion (DBI<sub>dc</sub>) Function

LPDDR4 SDRAM supports the function of Data Mask and Data Bus inversion. Its details are shown below.

- LPDDR4 device supports Data Mask (DM) function for Write operation.
- LPDDR4 device supports Data Bus Inversion (DBI<sub>dc</sub>) function for Write and Read operation.
- LPDDR4 supports DM and DBI<sub>dc</sub> function with a byte granularity.
- DBI<sub>dc</sub> function during Write or Masked Write can be enabled or disabled through MR3 OP[7].
- DBI<sub>dc</sub> function during Read can be enabled or disabled through MR3 OP[6].
- DM function during Masked Write can be enabled or disabled through MR13 OP[5].
- LPDDR4 device has one Data Mask Inversion (DMI) signal pin per byte; total of 2 DMI signals per channel.
- DMI signal is a bi-directional DDR signal and is sampled along with the DQ signals for Read and Write or Masked Write operation.

There are eight possible combinations for LPDDR4 device with DM and DBI<sub>dc</sub> function. Table below describes the functional behavior for all combinations.

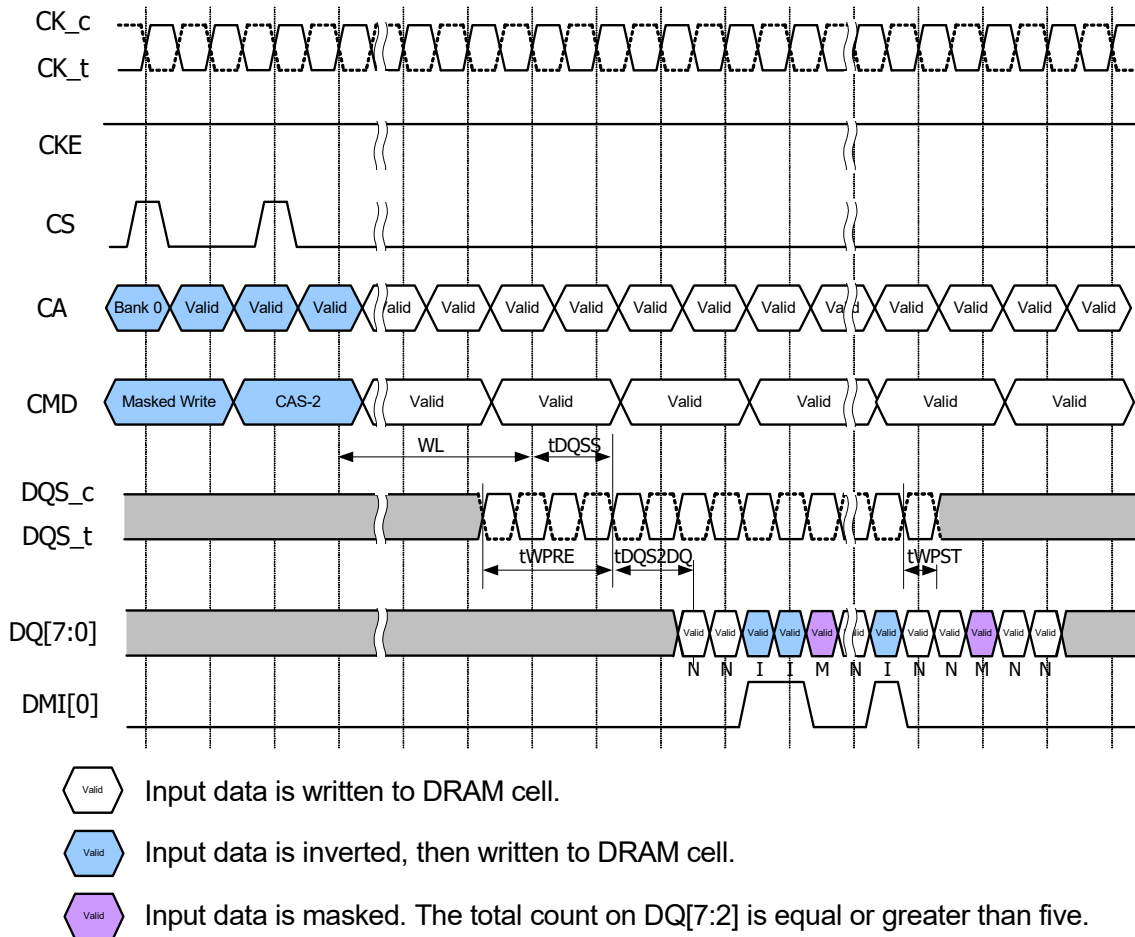
**Table - Function Behaviour of DMI Signal During Write, Masked Write and Read Operation**

DM Fuction	Write DBI <sub>dc</sub> Fuction	Read DBI <sub>dc</sub> Fuction	DMI Signal during Write Command	DMI Signal during Masked Write Command	DMI Signal during Read	DMI Signal during MPC [WR FIFO]	DMI Signal during MPC [RD FIFO]	DMI Signal during MPC [DQ Read calibration]	DMI Signal during MRR Command
Disable	Disable	Disable	Note: 1	Note: 1, 3	Note: 2	Note: 1	Note: 2	Note: 2	Note: 2
Disable	Enable	Disable	Note: 4	Note: 3	Note: 2	Note: 9	Note: 10	Note: 11	Note: 2
Disable	Disable	Enable	Note: 1	Note: 3	Note: 5	Note: 9	Note: 10	Note: 11	Note: 12
Disable	Enable	Enable	Note: 4	Note: 3	Note: 5	Note: 9	Note: 10	Note: 11	Note: 12
Enable	Disable	Disable	Note: 6	Note: 7	Note: 2	Note: 9	Note: 10	Note: 11	Note: 2
Enable	Enable	Disable	Note: 4	Note: 8	Note: 2	Note: 9	Note: 10	Note: 11	Note: 2
Enable	Disable	Enable	Note: 6	Note: 7	Note: 5	Note: 9	Note: 10	Note: 11	Note: 12
Enable	Enable	Enable	Note: 4	Note: 8	Note: 5	Note: 9	Note: 10	Note: 11	Note: 12

1. DMI input signal is a don't care. DMI input receivers are turned OFF.
2. DMI output drivers are turned OFF.
3. Masked Write Command is not allowed and is considered an illegal command as DM function is disabled.
4. DMI signal is treated as DBI signal and it indicates whether DRAM needs to invert the Write data received on DQs within a byte. The LPDDR4 device inverts Write data received on the DQ inputs in case DMI was sampled HIGH, or leaves the Write data non-inverted in case DMI was sampled LOW.
5. The LPDDR4 DRAM inverts Read data on its DQ outputs associated within a byte and drives DMI signal HIGH when the number of '1' data bits within a given byte lane is greater than four; otherwise the DRAM does not invert the read data and drives DMI signal LOW.
6. The LPDDR4 DRAM does not perform any mask operation when it receives Write command. During the Write burst associated with Write command, DMI signal must be driven LOW.
7. The LPDDR4 DRAM requires an explicit Masked Write command for all masked write operations. DMI signal is treated as DM signal and it indicates which bit time within the burst is to be masked. When DMI signal is HIGH, DRAM masks that bit time across all DQs associated within a byte. All DQ input signals within a byte are don't care (either HIGH or LOW) when DMI signal is HIGH. When DMI signal is LOW, the LPDDR4 DRAM does not perform mask operation and data received on DQ input is written to the array.
8. The LPDDR4 DRAM requires an explicit Masked Write command for all masked write operations. The LPDDR4 device masks the Write data received on the DQ inputs if the total count of '1' data bits on DQ[2:7] or DQ[10:15] (for Lower Byte or Upper Byte respectively) is equal to or greater than five and DMI signal is LOW. Otherwise the LPDDR4 DRAM does not perform mask operation and treats it as a legal DBI pattern; DMI signal is treated as DBI signal and data received on DQ input is written to the array.
9. DMI signal is treated as a training pattern. The LPDDR4 SDRAM does not perform any mask operation and does not invert Write data received on the DQ inputs.
10. DMI signal is treated as a training pattern. The LPDDR4 SDRAM returns DMI pattern written in WR-FIFO.

11. DMI signal is treated as a training pattern. For more details, see MPC RD DQ Calibration session.
12. DBI may apply or may not apply during normal MRR. It's vendor specific. If read DBI is enable with MRS and vendor cannot support the DBI during MRR, DBI pin status should be low.  
If read DBI is enable with MRS and vendor can support the DBI during MRR, the LPDDR4 DRAM inverts Mode Register Read data on its DQ outputs associated within a byte and drives DMI signal HIGH when the number of '1' data bits within a given byte lane is greater than four; otherwise the DRAM does not invert the read data and drives DMI signal LOW.

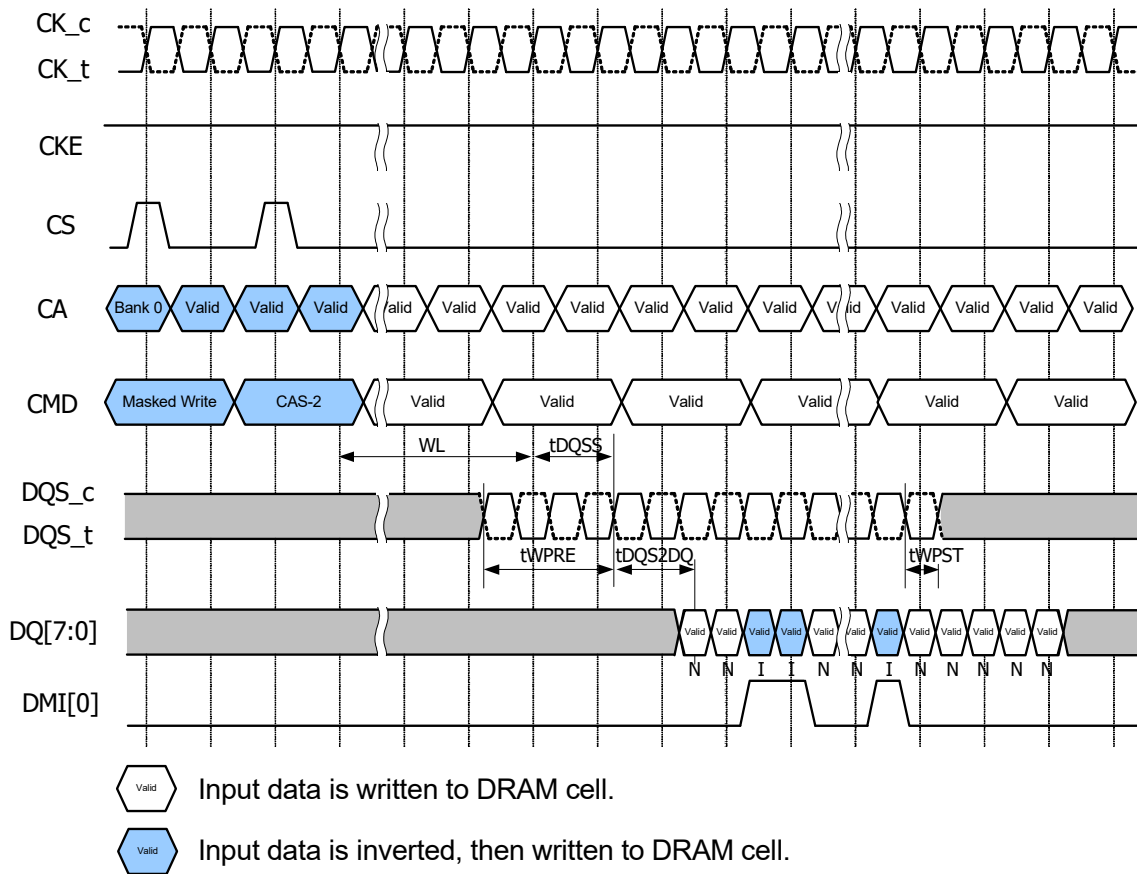
**Figure - Masked Write Operation w/ Write DBI Enabled; DM Enabled**



**Notes:**

1. Data Mask (DM) is Enabled; MR13 OP[5]=1, Data Bus Inversion (DBI) Write is Enabled; MR3 OP[7]=1.

**Figure - Write Command w/ Write DBI Enabled; DM Disabled**



**Notes:**

1. Data Mask (DM) is Disabled; MR13 OP[5]=0, Data Bus Inversion (DBI) Write is Enabled; MR3 OP[7]=1.

### 3.13. Precharge Operation

The PRECHARGE command is used to precharge or close a bank that has been activated. The PRECHARGE command is initiated with CS, and CA[5:0] in the proper state as defined by the Command Truth Table. The PRECHARGE command can be used to precharge each bank independently or all banks simultaneously. The AB flag and the bank address bit are used to determine which bank(s) to precharge. The precharged bank(s) will be available for subsequent row access tRPaB after an all-bank PRECHARGE command is issued, or tRPpB after a single-bank PRECHARGE command is issued.

To ensure that LPDDR4 devices can meet the instantaneous current demands, the row-precharge time for an all-bank PRECHARGE (tRPaB) is longer than the perbank precharge time (tRPpB).

**Table - Precharge Bank Selection**

AB (CA[5], R1)	BA2 (CA[2], R2)	BA1 (CA[1], R2)	BA0 (CA[0], R2)	Precharged Bank(s)
0	0	0	0	Bank 0 Only

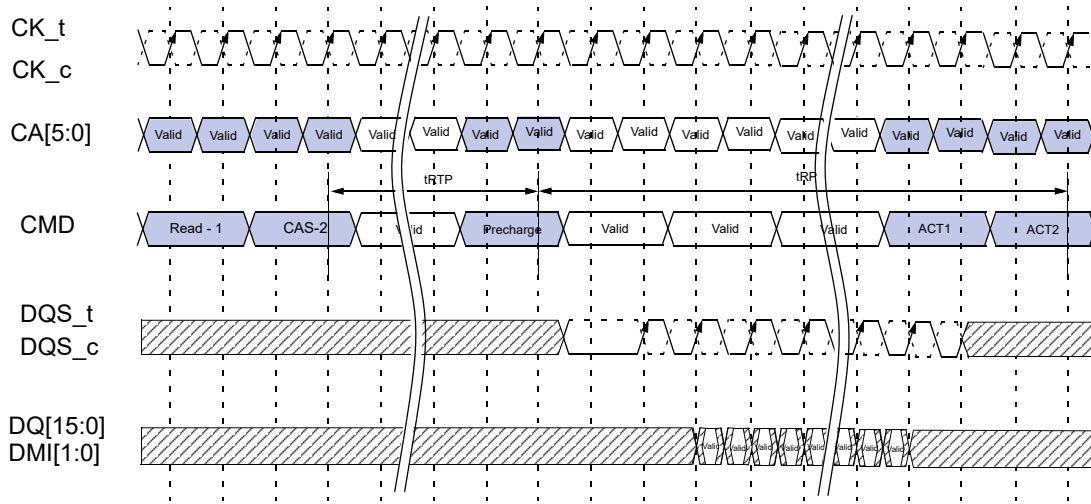


<b>AB (CA[5], R1)</b>	<b>BA2 (CA[2], R2)</b>	<b>BA1 (CA[1], R2)</b>	<b>BA0 (CA[0], R2)</b>	<b>Precharged Bank(s)</b>
0	0	0	1	Bank 1 Only
0	0	1	0	Bank 2 Only
0	0	1	1	Bank 3 Only
0	1	0	0	Bank 4 Only
0	1	0	1	Bank 5 Only
0	1	1	0	Bank 6 Only
0	1	1	1	Bank 7 Only
1	Valid	Valid	Valid	All banks

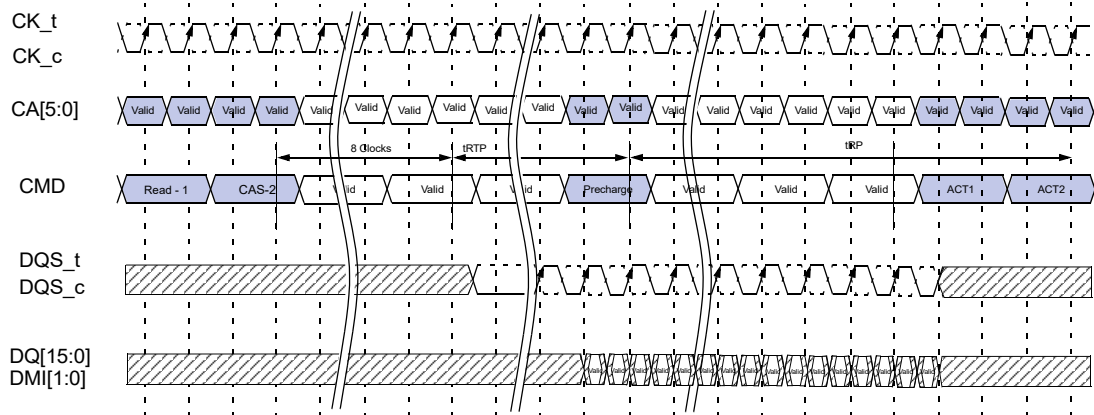
### 3.13.1. Burst Read Operation followed by Precharge

The PRECHARGE command can be issued as early as BL/2 clock cycles after a READ command, but PRECHARGE cannot be issued until after t<sub>RAS</sub> is satisfied. A new bank ACTIVATE command can be issued to the same bank after the row PRECHARGE time (t<sub>RP</sub>) has elapsed. The minimum READ-to-PRECHARGE time must also satisfy a minimum analog time from the 2nd rising clock edge of the CAS-2 command. t<sub>RTP</sub> begins BL/2 - 8 clock cycles after the READ command. For LPDDR4 READ-to-PRECHARGE timings see Table "Timing Between Commands (Precharge and Auto-Precharge)".

**Figure - Burst Read followed by Precharge (BL16, toggling pre-amble)**



**Figure - Burst Read followed by Precharge (BL32, Toggling Preamble)**

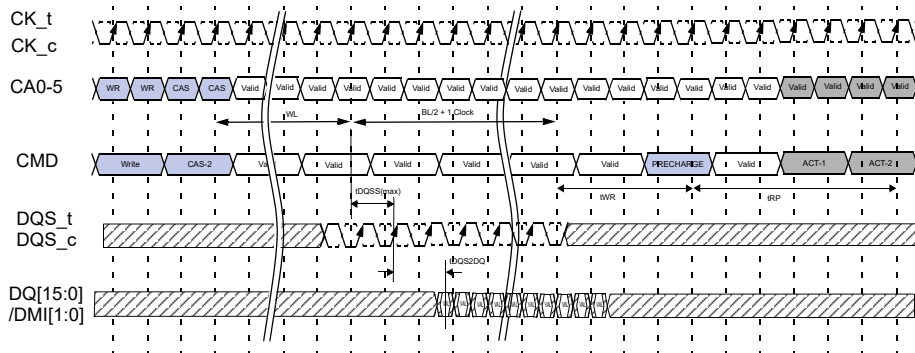


### 3.13.2. Burst Write followed by Precharge

A Write Recovery time ( $t_{WR}$ ) must be provided before a PRECHARGE command may be issued. This delay is referenced from the next rising edge of  $CK_t$  after the last latching DQS clock of the burst.

LPDDR4-SDRAM devices write data to the memory array in prefetch multiples (prefetch=16). An internal WRITE operation can only begin after a prefetch group has been clocked, so  $t_{WR}$  starts at the prefetch boundaries. The minimum WRITE-to-PRECHARGE time for commands to the same bank is  $WL + BL/2 + 1 + RU(t_{WR}/t_{CK})$  clock cycles.

**Figure - Burst Write followed by Precharge (BL16, 2tCK preamble)**



### 3.13.3. Auto Precharge operation

Before a new row can be opened in an active bank, the active bank must be precharged using either the PRECHARGE command or the Auto-PRECHARGE function. When a READ, WRITE or Masked Write command is issued to the device, the AP bit (CA5) can be set to enable the active bank to automatically begin precharge at the earliest possible moment during the burst READ, WRITE or Masked Write cycle.

If AP is LOW when the READ, WRITE or Masked Write command is issued, then the normal READ, WRITE or Masked Write burst operation is executed and the bank remains active at the completion of the burst.

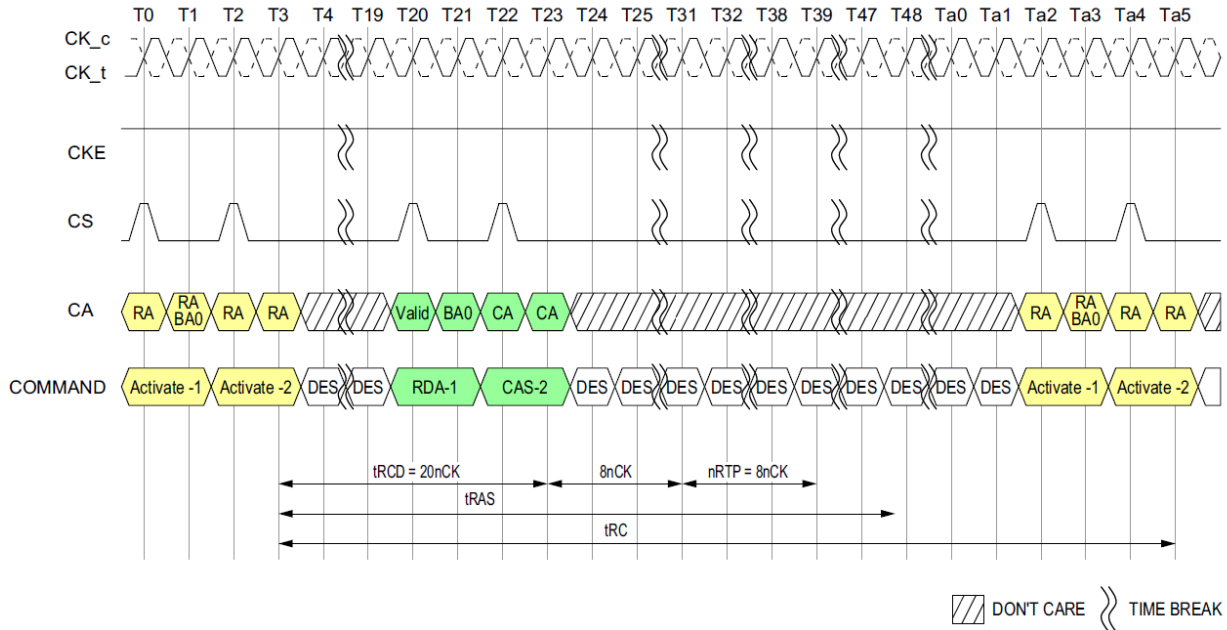
If AP is HIGH when the READ, WRITE or Masked Write command is issued, the Auto-PRECHARGE function is engaged. This feature enables the PRECHARGE operation to be partially or completely hidden during burst READ cycles (dependent upon READ or WRITE latency), thus improving system performance for random data access.

Read with Auto Precharge or Write/Mask Write with Auto Precharge commands may be issued after  $t_{RCD}$  has been satisfied. The LPDDR4 SDRAM RAS Lockout feature will schedule the internal precharge to assure that  $t_{RAS}$  is satisfied.

$t_{RC}$  needs to be satisfied prior to issuing subsequent Activate commands to the same bank.

The figure below shows example of RAS lock function.

**Figure - Command Input Timing with RAS lock**



**Note**

1.  $t_{CK(AVG)} = 0.938ns$ , Data Rate = 2133Mbps,  $t_{RCD(Min)} = \text{Max}(18ns, 4nCK)$ ,  $t_{RAS(Min)} = \text{Max}(42ns, 3nCK)$ ,  $nRTP = 8nCK$ ,  $BL = 32$
2.  $t_{RCD} = 20nCK$  comes from Roundup( $18ns/0.938ns$ )
3. DES commands are shown for ease of illustration; other commands may be valid at these times.

**3.13.3.1. Burst Read with Auto-Precharge**

If AP is HIGH when a READ command is issued, the READ with Auto-PRECHARGE function is engaged. An internal pre-charge procedure starts a following delay time after the READ command. And this delay time depends on BL setting.

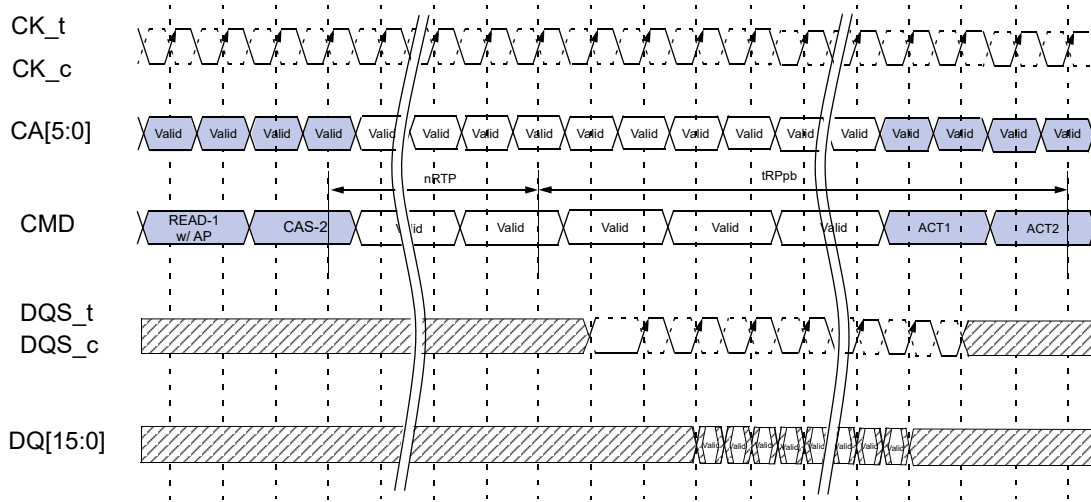
BL = 16:  $t_{RTP}$

BL = 32:  $8t_{CK} + t_{RTP}$

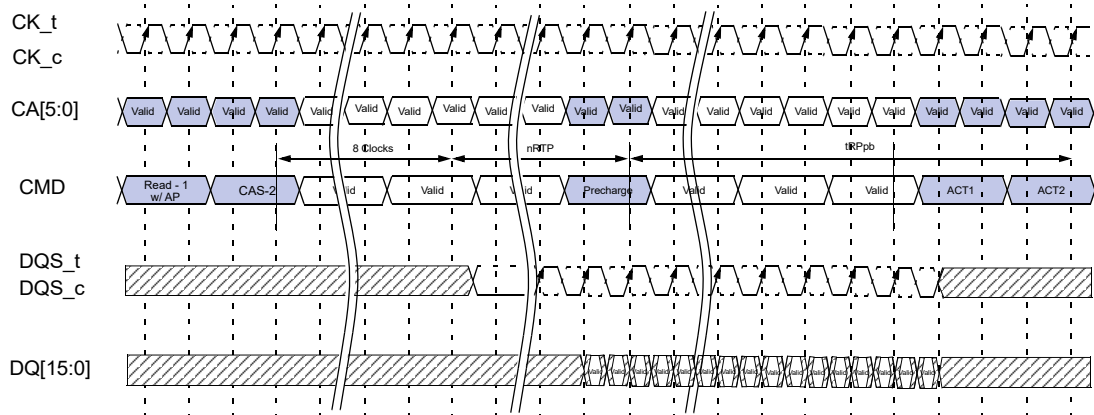
For LPDDR4 Auto-PRECHARGE calculations, see Table 2. Following an Auto-PRECHARGE operation, an ACTIVATE command can be issued to the same bank if the following two conditions are both satisfied:

- a. The RAS precharge time ( $t_{RP}$ ) has been satisfied from the clock at which the Auto-PRECHARGE began, or
- b. The RAS cycle time ( $t_{RC}$ ) from the previous bank activation has been satisfied.

**Figure - Burst Read with Auto-Precharge (BL16, Toggling preamble)**



**Figure - Burst Read with Auto-Precharge (BL32, Toggling preamble)**

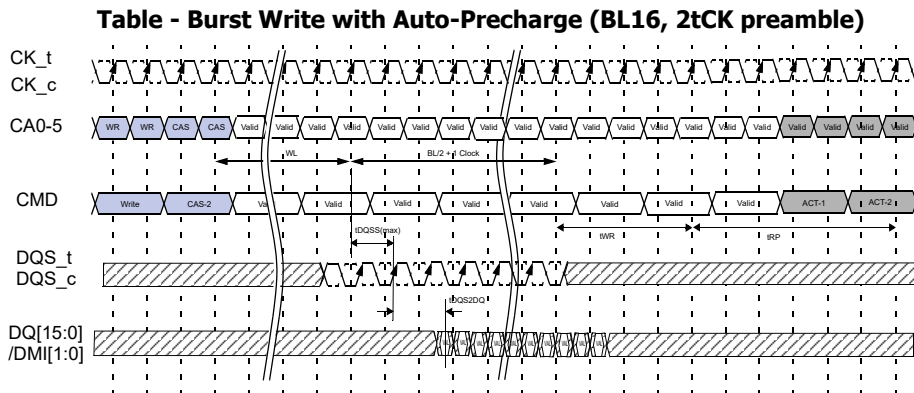


### 3.13.3.2. Burst Write with Auto-Precharge

If AP is HIGH when a WRITE command is issued, the WRITE with Auto-PRECHARGE function is engaged. The device starts an Auto-PRECHARGE on the rising edge tWR cycles after the completion of the Burst WRITE.

Following a WRITE with Auto-PRECHARGE, an ACTIVATE command can be issued to the same bank if the following conditions are met:

- a. The RAS precharge time (tRP) has been satisfied from the clock at which the Auto-PRECHARGE began, and
- b. The RAS cycle time (tRC) from the previous bank activation has been satisfied.



**Table - Timing Between Commands (Precharge and Auto-Precharge) - DQ ODT is Disabled**

From Command	To Command	Minimum Delay between "From Command" and "To Command"	Unit	Notes
Read (BL16)	Precharge (to same bank as Read)	tRTP	tCK	1,6
	Precharge All	tRTP	tCK	1,6
Read (BL32)	Precharge (to same bank as Read)	8*tCK + tRTP	tCK	1,6
	Precharge All	8*tCK + tRTP	tCK	1,6
Read w/ AP (BL16)	Precharge (to same bank as Read w/ AP)	nRTP	tCK	1,10
	Precharge All	nRTP	tCK	1,10
	Activate (to same bank as Read w/ AP)	nRTP + tRPpb	tCK	1,8,10
	Write or Write w/ AP (same bank)	Illegal	-	3
	Masked Write or Masked Write w/ AP (same bank)	Illegal	-	
	Write or Write w/ AP (different bank)	RL+RU(tDQSCK(max)/tCK)+BL/2+RD(trpST)-WL+tWPRE	tCK	3,4,5
Masked Write or Masked Write w/ AP (different bank)	RL+RU(tDQSCK(max)/tCK)+BL/2+RD(trpST)-WL+tWPRE	tCK	3,4,5	

From Command	To Command	Minimum Delay between "From Command" and "To Command"	Unit	Notes
Read w/ AP (BL16)	Read or Read w/ AP (same bank)	Illegal	-	
	Read or Read w/ AP (different bank)	BL/2	tCK	3
Read w/ AP (BL32)	Precharge (to same bank as Read w/ AP)	8*tCK + nRTP	tCK	1,10
	Precharge All	8*tCK + nRTP	tCK	1,10
	Activate (to same bank as Read w/ AP)	8*tCK + nRTP + tRPpb	tCK	1,8,10
	Write or Write w/ AP (same bank)	Illegal	-	
	Masked Write or Masked Write w/ AP (same bank)	Illegal	-	
	Write or Write w/ AP (different bank)	RL+RU(tDQSCK(max)/tCK)+BL/2+RD(tRPST)-WL+tWPRE	tCK	3,4,5
	Masked Write or Masked Write w/ AP (different bank)	RL+RU(tDQSCK(max)/tCK)+BL/2+RD(tRPST)-WL+tWPRE	tCK	3,4,5
	Read or Read w/ AP (same bank)	Illegal	-	
Write (BL16 & BL32)	Precharge (to same bank as Masked Write)	WL + BL/2 + tWR + 1	tCK	1,7
	Precharge All	WL + BL/2 + tWR + 1	tCK	1,7
Masked Write	Precharge (to same bank as Masked Write)	WL + BL/2 + tWR + 1	tCK	1,7
	Precharge All	WL + BL/2 + tWR + 1	tCK	1,7
Write w/ AP	Precharge (to same bank as Write w/ AP)	WL + BL/2 + nWR + 1	tCK	1,11
	Precharge All	WL + BL/2 + nWR + 1	tCK	1,11
	Activate (to same bank as Write w/ AP)	WL + BL/2 + nWR + 1 + tRPpb	tCK	1,8,11
	Write or Write w/ AP (same bank)	Illegal	-	
	Write or Write w/ AP (different bank)	BL/2	tCK	3
	Masked-Write or Masked-Write w/ AP (different bank)	BL/2	tCK	3
	Read or Read w/ AP (same bank)	Illegal	-	
	Read or Read w/ AP (different bank)	WL + BL/2 + tWTR + 1	tCK	3,9

From Command	To Command	Minimum Delay between "From Command" and "To Command"	Unit	Notes
Masked Write w/ AP	Precharge (to same bank as Masked Write w/ AP)	$WL + BL/2 + nWR + 1$	tCK	1,11
	Precharge all	$WL + BL/2 + nWR + 1$	tCK	1,11
	Activate (to same bank as Masked Write w/ AP)	$WL + BL/2 + nWR + 1 + tRPpb$	tCK	1,8,11
	Write or Write w/ AP (same bank)	Illegal	-	
	Masked Write or Masked Write w/ AP (same bank)	Illegal	-	
	Write or Write w/ AP (different bank)	BL/2	tCK	3
	Masked Write or Masked Write w/ AP (different bank)	BL/2	tCK	3
	Read or Read w/ AP (same bank)	Illegal	-	
	Read or Read w/ AP (different bank)	$WL + BL/2 + tWTR + 1$	tCK	3,9
Precharge	Precharge (to same bank as Precharge)	4	tCK	1
	Precharge All	4	tCK	1
Precharge All	Precharge	4	tCK	1
	Precharge All	4	tCK	1

**Notes**

- For a given bank, the precharge period should be counted from the latest precharge command, whether per-bank or all-bank, issued to that bank. The precharge period is satisfied tRP after that latest precharge command.
- Any command issued during the minimum delay time as specified in the table above is illegal.
- After READ w/AP, seamless read operations to different banks are supported. After WRITE w/AP or Masked Write w/AP, seamless write operations to different banks are supported. READ, WRITE, and Masked Write operations may not be truncated or interrupted.
- tRPST values depend on MR1 OP[7] respectively
- tWPST values depend on MR1 OP[2] respectively
- Minimum Delay between "From Command" and "To Command" in clock cycle is calculated by dividing tRTP(in ns) by tCK(in ns) and rounding up to the next integer:  $\text{Minimum Delay}[\text{cycles}] = \text{Roundup}(tRTP[\text{ns}] / tCK[\text{ns}])$
- Minimum Delay between "From Command" and "To Command" in clock cycle is calculated by dividing tWR(in ns) by tCK(in ns) and rounding up to the next integer:  $\text{Minimum Delay}[\text{cycles}] = \text{Roundup}(tWR[\text{ns}] / tCK[\text{ns}])$
- Minimum Delay between "From Command" and "To Command" in clock cycle is calculated by dividing tRPpb(in ns) by tCK(in ns) and rounding up to the next integer:  $\text{Minimum Delay}[\text{cycles}] = \text{Roundup}(tRPpb[\text{ns}] / tCK[\text{ns}])$
- Minimum Delay between "From Command" and "To Command" in clock cycle is calculated by dividing tWTR(in ns) by tCK(in ns) and rounding up to the next integer:  $\text{Minimum Delay}[\text{cycles}] = \text{Roundup}(tWTR[\text{ns}] / tCK[\text{ns}])$
- For Read w/AP the value is nRTP which is defined in Mode Register 2.
- For Write w/AP the value is nWR which is defined in Mode Register 1.

**Table - Timing Between Commands (Precharge and Auto-Precharge) - DQ ODT is Enabled**

From Command	To Command	Minimum Delay between "From Command" and "To Command"	Unit	Notes
Read w/ AP (BL16)	Write or Write w/ AP (different bank)	$RL + RU(tDQSCK(\text{max})/tCK) + BL/2 + RD(tRPST) - ODTLon - RD(tODTon, \text{min}/tCK) + 1$	tCK	2,3
	Masked Write or Masked Write w/ AP (different bank)	$RL + RU(tDQSCK(\text{max})/tCK) + BL/2 + RD(tRPST) - ODTLon - RD(tODTon, \text{min}/tCK) + 1$	tCK	2,3
Read w/ AP (BL32)	Write or Write w/ AP (different bank)	$RL + RU(tDQSCK(\text{max})/tCK) + BL/2 + RD(tRPST) - ODTLon - RD(tODTon, \text{min}/tCK) + 1$	tCK	2,3
	Masked Write or Masked Write w/ AP (different bank)	$RL + RU(tDQSCK(\text{max})/tCK) + BL/2 + RD(tRPST) - ODTLon - RD(tODTon, \text{min}/tCK) + 1$	tCK	2,3

**Notes**

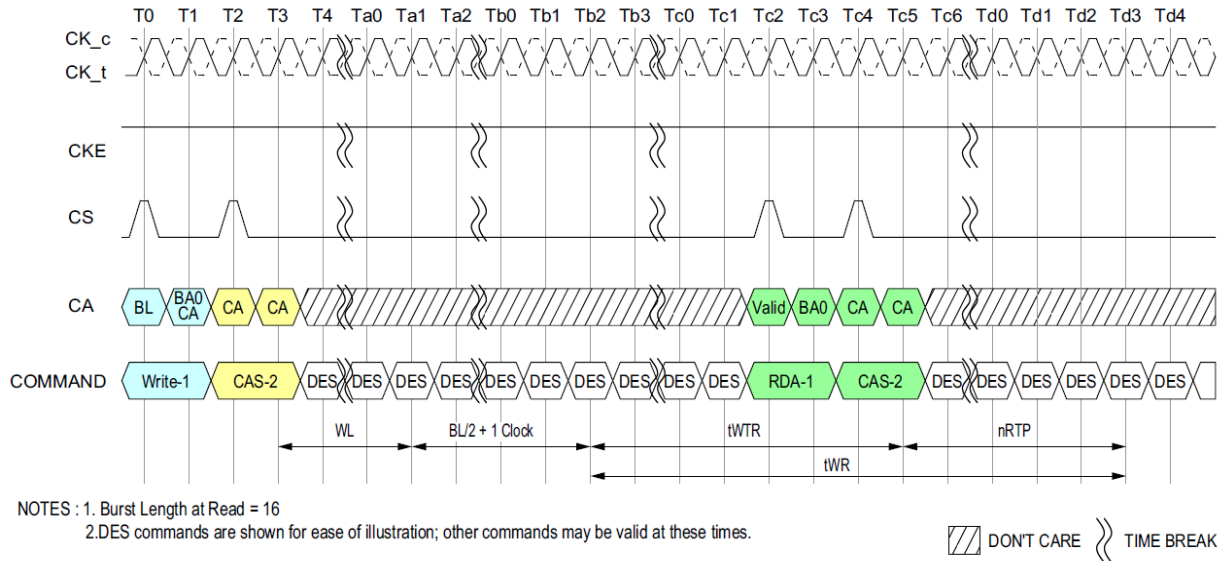
- The rest of Precharge and Auto-Precharge timings are as same as DQ ODT disabled case.
- After READ w/AP, seamless read operations to different banks are supported. READ, WRITE, and Masked Write operations may



- not be truncated or interrupted.
- 3. tRPST values depend on MR1 OP[7] respectively.

### 3.13.3.3. Delay Time from Write to Read with Auto Precharge

In the case of write command followed by read with auto-precharge, controller must satisfy tWR for the write command before initiating the DRAM internal auto-precharge. It means that (tWTR + nRTP) should be equal or longer than (tWR) when BL setting is 16, as well as (tWTR + nRTP + 8nCK) should be equal or longer than (tWR) when BL setting is 32. Refer to the following figure for details.



### 3.14. Refresh command

The REFRESH command is initiated with CS HIGH, CA0 LOW, CA1 LOW, CA2 LOW, CA3 HIGH and CA4 LOW at the first rising edge of the clock. Per-bank REFRESH is initiated with CA5 LOW at the first rising edge of the clock. All-bank REFRESH is initiated with CA5 HIGH at the first rising edge of the clock.

A per-bank REFRESH command (REFpb) is performed to the bank address as transferred on CA0, CA1 and CA2 at the second rising edge of the clock. Bank address BA0 is transferred on CA0, bank address BA1 is transferred on CA1 and bank address BA2 is transferred on CA2. A per-bank REFRESH command (REFpb) to the eight banks can be issued in any order. e.g. REFpb commands are issued in the following order: 1-3-0-2-4-7-5-6. After the eight banks have been refreshed using the per-bank REFRESH command the controller can send another set of per-bank REFRESH commands in the same order or a different order. e.g. REFpb commands are issued in the following order that is different from the previous order: 7-1-3-5-0-4-2-6. One of the possible order can also be a sequential round robin: 0-1-2-3-4-5-6-7. It is illegal to send a per-bank REFRESH command to the same bank unless all eight banks have been refreshed using the per-bank REFRESH command. The count of eight REFpb commands starts with the first REFpb command after a synchronization event.

The bank count is synchronized between the controller and the SDRAM by resetting the bank count to zero. Synchronization can occur upon asserting RESET\_n or at every exit from self refresh. REFab command also synchronizes the

counter between the controller and SDRAM to zero. The SDRAM device can be placed in self-refresh or a REFab command can be issued at any time without cycling through all eight banks using per-bank REFRESH command. After the bank count is synchronized to zero the controller can issue per-bank REFRESH commands in any order as described in the previous paragraph.

A REFab command issued when the bank counter is not zero will reset the bank counter to zero and the DRAM will perform refreshes to all banks as indicated by the row counter. If another refresh command (REFab or REFpb) is issued after the REFab command then it uses an incremented value of the row counter.

The table below shows examples of both bank and refresh counter increment behavior.

**Table - Bank and Refresh counter increment behavior**

#	Sub #	Command	BA2	BA1	BA0	Refresh Bank#	Bank Counter #	Ref Counter # (Row Address #)	
0	0	Reset, SRX or REFab						To 0	-
1	1	REFpb	0	0	0	0	0 to 1	n	
2	2	REFpb	0	0	1	1	1 to 2		
3	3	REFpb	0	1	0	2	2 to 3		
4	4	REFpb	0	1	1	3	3 to 4		
5	5	REFpb	1	0	0	4	4 to 5		
6	6	REFpb	1	0	1	5	5 to 6		
7	7	REFpb	1	1	0	6	6 to 7		
8	8	REFpb	1	1	1	7	7 to 0		
9	1	REFpb	1	1	0	6	0 to 1	n + 1	
10	2	REFpb	1	1	1	7	1 to 2		
11	3	REFpb	0	0	1	1	2 to 3		
12	4	REFpb	0	1	1	3	3 to 4		
13	5	REFpb	1	0	1	5	4 to 5		
14	6	REFpb	0	1	0	2	5 to 6		
15	7	REFpb	0	0	0	0	6 to 7		
16	8	REFpb	1	0	0	4	7 to 0		
17	1	REFpb	0	0	0	0	0 to 1	n + 2	
18	2	REFpb	0	0	1	1	1 to 2		
19	3	REFpb	0	1	0	2	2 to 3		
<b>24</b>	<b>0</b>	<b>REFab</b>	<b>V</b>	<b>V</b>	<b>V</b>	<b>0~7</b>	<b>To 0</b>	<b>n + 2</b>	
25	1	REFpb	1	1	0	6	0 to 1	n + 3	
26	2	REFpb	1	1	1	7	1 to 2		
Snip									

A bank must be idle before it can be refreshed. The controller must track the bank being refreshed by the per-bank REFRESH command.

The REFpb command must not be issued to the device until the following conditions are met:

- tRFCab has been satisfied after the prior REFab command
- tRFCpb has been satisfied after the prior REFpb command

- tRP has been satisfied after the prior PRECHARGE command to that bank
- tRRD has been satisfied after the prior ACTIVATE command (if applicable, for example after activating a row in a different bank than the one affected by the REFpb command).

The target bank is inaccessible during per-bank REFRESH cycle time (tRFCpb), however, other banks within the device are accessible and can be addressed during the cycle. During the REFpb operation, any of the banks other than the one being refreshed can be maintained in an active state or accessed by a READ or a WRITE command. When the per-bank REFRESH cycle has completed, the affected bank will be in the idle state.

After issuing REFpb, these conditions must be met:

- tRFCpb must be satisfied before issuing a REFab command
- tRFCpb must be satisfied before issuing an ACTIVATE command to the same bank
- tRRD must be satisfied before issuing an ACTIVATE command to a different bank
- tRFCpb must be satisfied before issuing another REFpb command.

An all-bank REFRESH command (REFab) issues a REFRESH command to all banks. All banks must be idle when REFab is issued (for instance, by issuing a PRECHARGE-all command prior to issuing an all-bank REFRESH command). REFab also synchronizes the bank count between the controller and the SDRAM to zero. The REFab command must not be issued to the device until the following conditions have been met:

- tRFCab has been satisfied following the prior REFab command
- tRFCpb has been satisfied following the prior REFpb command
- tRP has been satisfied following the prior PRECHARGE commands.

When an all-bank refresh cycle has completed, all banks will be idle. After issuing REFab:

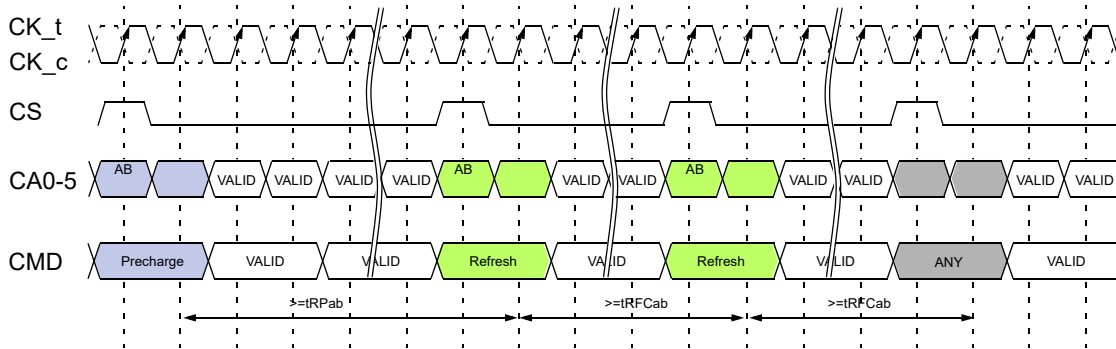
- tRFCab latency must be satisfied before issuing an ACTIVATE command
- tRFCab latency must be satisfied before issuing a REFab or REFpb command.

**Table - REFRESH Command Scheduling Separation requirements**

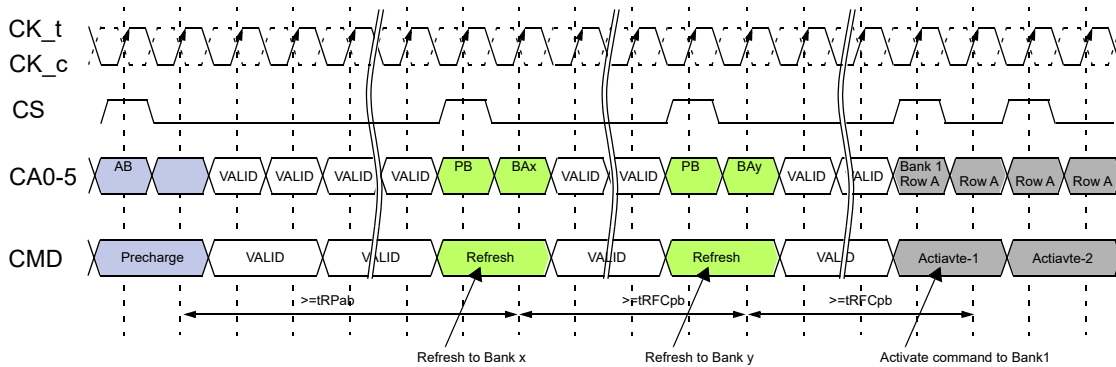
Symbol	minimum delay from	to	Notes
tRFCab	REFab	REFab	
		Activate command to any bank	
		REFpb	
tRFCpb	REFpb	REFab	
		Activate command to same bank as REFpb	
		REFpb	
tRRD	REFpb	Activate command to different bank than REFpb	
	Activate	REFpb	1
		Activate command to different bank than prior Activate command	

Note:  
1. A bank must be in the idle state before it is refreshed, so following an ACTIVATE command REFab is prohibited; REFpb is supported only if it affects a bank that is in the idle state.

**Figure - All-Bank REFRESH Operation**



**Figure - Per-Bank REFRESH Operation**



1. Operations to banks other than the bank being refreshed are supported during the tRFCpb period.

In general, a Refresh command needs to be issued to the LPDDR4 SDRAM regularly every tREFI interval. To allow for improved efficiency in scheduling and switching between tasks, some flexibility in the absolute refresh interval is provided. A maximum of 8 Refresh commands can be postponed during operation of the LPDDR4 SDRAM, meaning that at no point in time more than a total of 8 Refresh commands are allowed to be postponed and maximum number of pulled-in or postponed REF command is dependent on refresh rate. It is described in the table below. In case that 8 Refresh commands are postponed in a row, the resulting maximum interval between the surrounding Refresh commands is limited to  $9 \times tREFI$ . A maximum of 8 additional Refresh commands can be issued in advance ("pulled in"), with each one reducing the number of regular Refresh commands required later by one. Note that pulling in more than 8 Refresh commands in advance does not further reduce the number of regular Refresh commands required later, so that the resulting maximum interval between two surrounding Refresh commands is limited to  $9 \times tREFI$ . At any given time, a maximum of 16 REF commands can be issued within  $2 \times tREFI$ .

Self-Refresh Mode may be entered with a maximum of eight Refresh commands being postponed. After exiting Self-Refresh Mode with one or more Refresh commands postponed, additional Refresh commands may be postponed to the extent that the total number of postponed Refresh commands (before and after the Self-Refresh) will never exceed eight. During Self-Refresh Mode, the number of postponed or pulled-in REF commands does not change.

And for per bank refresh, a maximum 8 x 8 per bank refresh commands can be postponed or pulled in for scheduling efficiency. At any given time, a maximum of 2 x 8 x 8 per bank refresh commands can be issued within 2 x tREFI.

**Table - Legacy Refresh Command Timing Constraints**

MR4 OP[2:0]	Refresh rate	Max. No. of pulled in or postponed REFab	Max. interval between two REFab	Max. No. of REFab within max(2*tREFI*Refresh rate multiplier, 16*tRFC)	Per-bank Refresh
000B	Low Temp. Limit	N/A	N/A	N/A	N/A
001B	4 x tREFI	8	9 x 4 x tREFI	16	1/8 of REFab
010B	2 x tREFI	8	9 x 2 x tREFI	16	1/8 of REFab
011B	1 x tREFI	8	9 x tREFI	16	1/8 of REFab
100B	0.5 x tREFI	8	9 x 0.5 x tREFI	16	1/8 of REFab
101B	0.25 x tREFI	8	9 x 0.25 x tREFI	16	1/8 of REFab
110B	0.25 x tREFI	8	9 x 0.25 x tREFI	16	1/8 of REFab
111B	High Temp. Limit	N/A	N/A	N/A	N/A

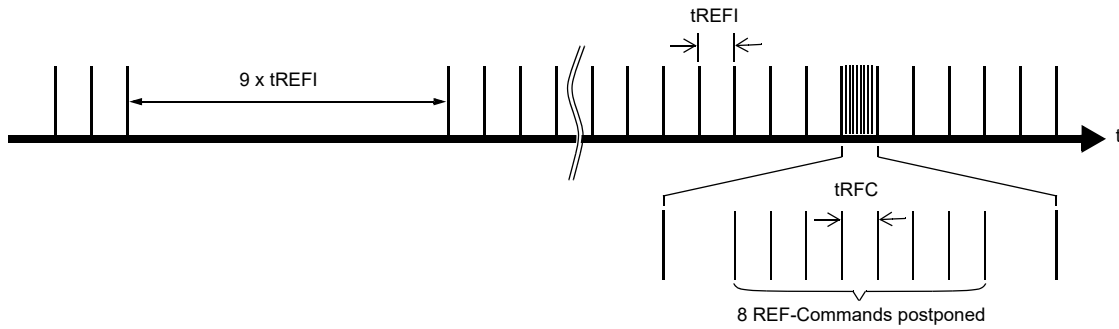
**Table - Modified Refresh Command Timing Constraints**

MR4 OP[2:0]	Refresh rate	Max. No. of pulled in or postponed REFab	Max. interval between two REFab	Max. No. of REFab within max(2*tREFI*Refresh rate multiplier, 16*tRFC)	Per-bank Refresh
000B	Low Temp. Limit	N/A	N/A	N/A	N/A
001B	4 x tREFI	2	3 x 4 x tREFI	4	1/8 of REFab
010B	2 x tREFI	4	5 x 2 x tREFI	8	1/8 of REFab
011B	1 x tREFI	8	9 x tREFI	16	1/8 of REFab
100B	0.5 x tREFI	8	9 x 0.5 x tREFI	16	1/8 of REFab
101B	0.25 x tREFI	8	9 x 0.25 x tREFI	16	1/8 of REFab
110B	0.25 x tREFI	8	9 x 0.25 x tREFI	16	1/8 of REFab
111B	High Temp. Limit	N/A	N/A	N/A	N/A

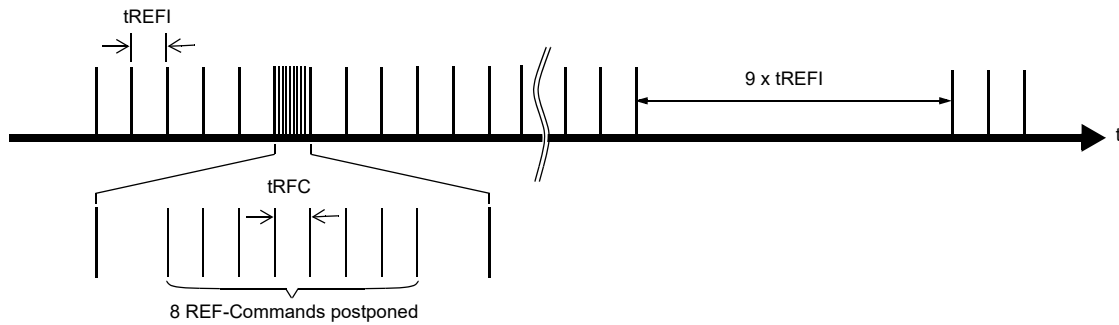
Notes:

1. For any thermal transition phase where Refresh mode is transitioned to either 2x tREFI or 4x tREFI, DRAM will support the previous postponed refresh requirement provided the number of postponed refreshes is monotonically reduced to meet the new requirement. However, the pulled-in refresh commands in previous thermal phase are not applied in new thermal phase. Entering new thermal phase the controller must count the number of pulled-in refresh commands as zero, regardless of remaining pulled-in refresh commands in previous thermal phase.
2. LPDDR4 devices are refreshed properly if memory controller issues refresh commands with same or shorter refresh period than reported by MR4 OP[2:0]. If shorter refresh period is applied, the corresponding requirements from Table apply. For example, when MR4 OP[2:0]=001B, controller can be in any refresh rate from 4xtREFI to 0.25x tREFI. When MR4 OP[2:0]=010B, the only prohibited refresh rate is 4x tREFI.

**Figure - Postponing Refresh Commands (Example)**



**Figure - Pulling-in Refresh Commands (Example)**



### 3.15. LPDDR4 Refresh Requirements by Device Density

Between SRX command and SRE command, at least one extra refresh command is required. After the DRAM Self Refresh Exit command, in addition to the normal Refresh command at tREFI interval, the LPDDR4 DRAM requires minimum of one extra Refresh command prior to Self Refresh Entry command.

**Table - Refresh Requirement Parameters per die**

Density	Symbol	4Gb	6Gb	8Gb	12Gb	16Gb	Unit
Density per channel		2Gb	3Gb	4Gb	6Gb	8Gb	-
Number of Banks		8					-
Refresh Window 1 x tREFI	tREFW	32					ms
Refresh Window 0.5 x tREFI	tREFW	16					ms
Refresh Window 0.25 x tREFI	tREFW	8					ms
Required number of REFRESH commands	R	8,192					-
Average Refresh Interval 1 x tREFI	REFab	tREFI					us
	REFpb	tREFIpb					ns
Average Refresh Interval 0.5 x tREFI	REFab	tREFI					us
	REFpb	tREFIpb					ns
Average Refresh Interval 0.25 x tREFI	REFab	tREFI					us
	REFpb	tREFIpb					ns
Refresh Cycle Time (All Banks)	tRFCab	130	180	180	280		ns
Refresh Cycle Time (per Bank)	tRFCpb	60	90	90	140		ns
Per-bank Refresh to Per-bank Refresh different bank Tim	tp-bR2pbR	60	90				ns

Notes:

1. Refresh for each channel is independent of the other channel on the die, or other channels in a package. Power delivery in the user's system should be verified to make sure the DC operating conditions are maintained when multiple channels are refreshed simultaneously.
2. Self refresh abort feature is available for higher density devices starting with 12 Gb device and tXSR\_abort(min) is defined as tRFCpb + 17.5ns.

### 3.16. Self Refresh Operation

#### 3.16.1. Self Refresh Entry and Exit

The Self Refresh command can be used to retain data in the LPDDR4 SDRAM, the SDRAM retains data without external Refresh command. The device has a built-in timer to accommodate Self Refresh operation. The Self Refresh is entered by Self Refresh Entry Command defined by having CKE High, CS High, CA0 Low, CA1 Low, CA2 Low; CA3 High; CA4 High, CA5 Valid (Valid that means it is Logic Level, High or Low) for the first rising edge and CKE High, CS Low, CA0 Valid, CA1 Valid, CA2 Valid, CA3 Valid, CA4 Valid, CA5 Valid at the second rising edge of the clock. Self Refresh command is only allowed when SDRAM is idle state.

During Self Refresh mode, external clock input is needed and all input pin of SDRAM are activated. SDRAM can accept the following commands, MRR-1, CAS-2, SRX, MPC, MRW-1, and MRW-2 except PASR Bank/Segment setting.

LPDDR4 SDRAM can operate in Self Refresh in both the standard or elevated temperature ranges. SDRAM will also manage Self Refresh power consumption when the operating temperature changes, lower at low temperature and higher at high temperatures.

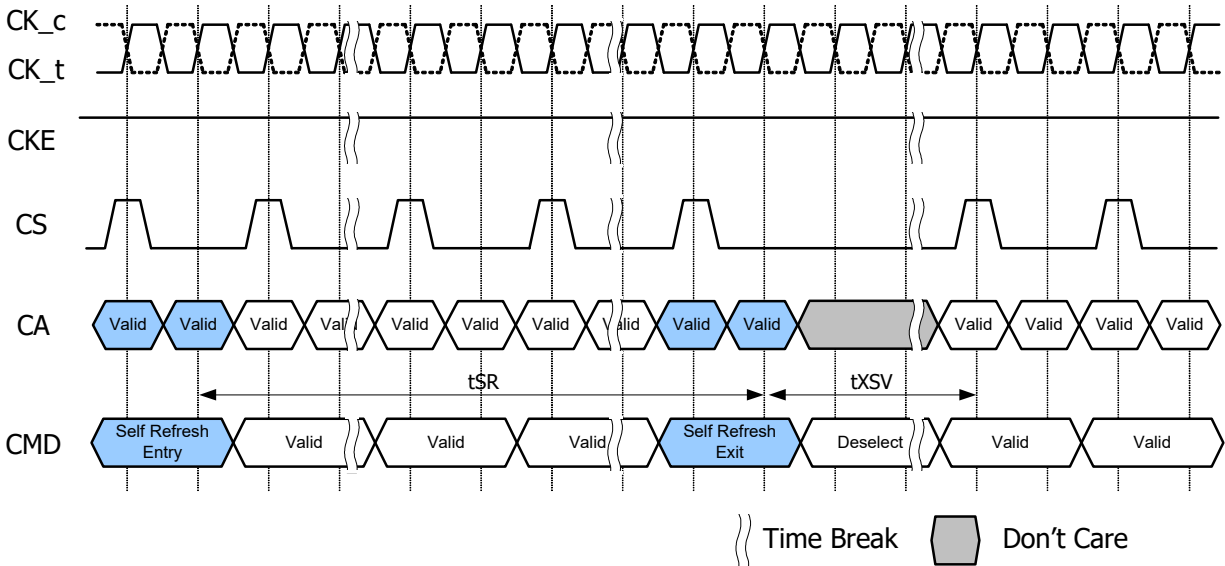
For proper Self Refresh operation, power supply pins (VDD1 and VDD2) must be at valid levels. VDDQ may be turned off during Self-Refresh after tESCKE is satisfied (Refer to Figure-Self Refresh Entry/Exit Timing with Power Down Entry/Exit for tESCKE).

Prior to exiting Self-Refresh VDDQ must be within specified limits. The minimum time that the SDRAM must remain in Self Refresh model is tSR,min.

The use of Self Refresh mode introduces the possibility that an internally timed refresh event can be missed when Self Refresh Exit is registered. Upon exit from Self Refresh, it is required that at least one REFRESH command (8 per-bank or 1 all-bank) is issued before entry into a subsequent Self Refresh.



**Figure - Self Refresh Entry/Exit Timing**

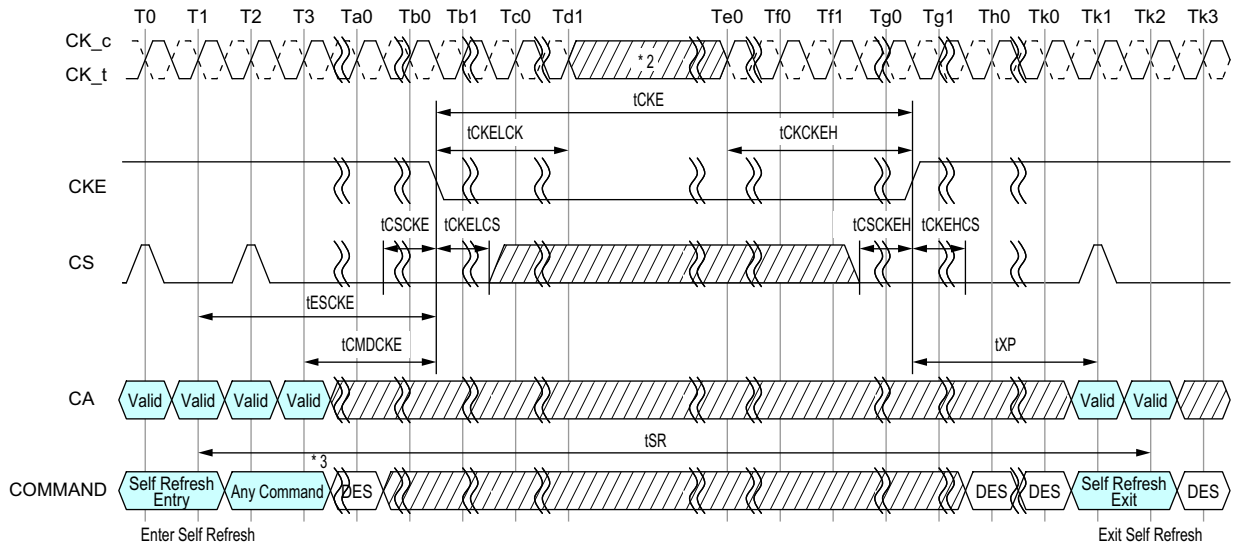


1. MRR-1, CAS-2, SRX, MPC, MRW-1 and MRW-2 except PASR Bank/Segment setting is allowed during Self Refresh.
2. Address input may be don't care when input command is Deselect.

### 3.16.2. Power Down Entry and Exit during Self Refresh



Entering/Exiting Power Down Mode is allowed during Self Refresh mode in LPDDR4 SDRAM. The related timing parameters between Self Refresh Entry/Exit and Power Down Entry/Exit are shown in Figure-Self Refresh Entry/Exit Timing with Power Down Entry/Exit.

**Figure - Self Refresh Entry/Exit Timing with Power Down Entry/Exit**



**NOTES:**

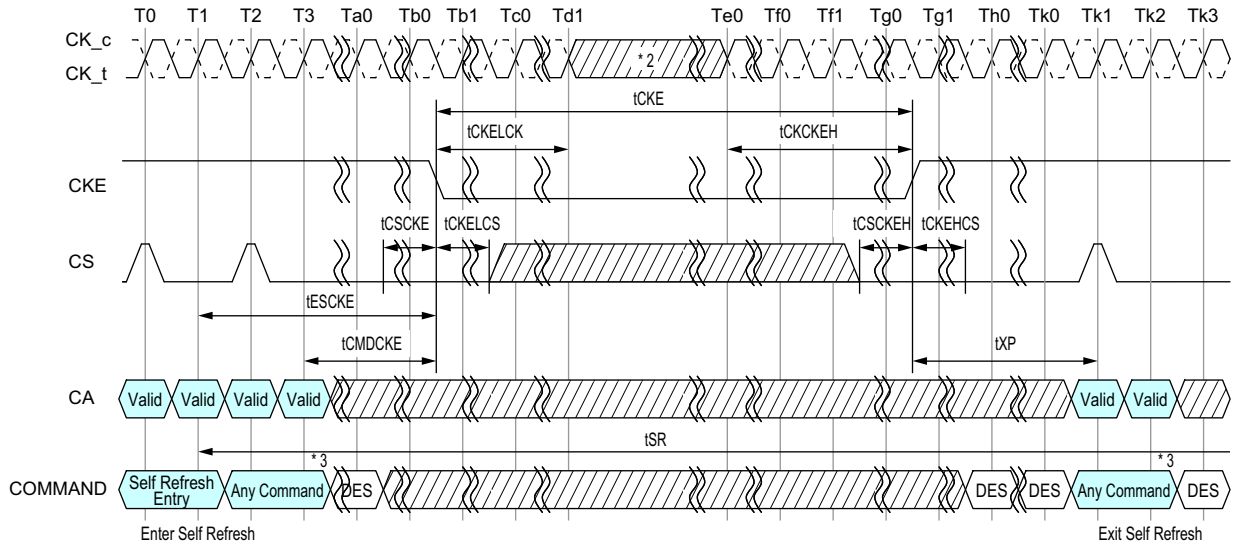
1. MRR-1, CAS-2, DES, SRX, MPC, MRW-1 and MRW-2 except PASR Bank/Segment setting is allowed during Self Refresh.
2. Input clock frequency can be changed or the input clock can be stopped or floated after tCKELCK satisfied and during power-down, provided that upon exiting power-down, the clock is stable and within specified limits for a minimum of tCKCKEH of stable clock prior to power-down exit and the clock frequency is between the minimum and maximum specified frequency for the speed grade in use.
3. 2 Clock command for example.

 DONT CARE
  TIME BREAK

### 3.16.3. Command Input Timing after Power Down Exit

Command input timings after Power Down Exit during Self Refresh mode are shown in Figure-Command input timings after Power Down Exit during Self Refresh.

**Figure - Command input timings after Power Down Exit during Self Refresh**



**NOTES:**

1. MRR-1, CAS-2, DES, SRX, MPC, MRW-1 and MRW-2 except PASR Bank/Segment setting is allowed during Self Refresh.
2. Input clock frequency can be changed or the input clock can be stopped or floated after tCKELCK satisfied and during power-down, provided that upon exiting power-down, the clock is stable and within specified limits for a minimum of tCKCKEH of stable clock prior to power-down exit and the clock frequency is between the minimum and maximum specified frequency for the speed grade in use.
3. 2 Clock command for example.

 DONT CARE  TIME BREAK

### 3.16.4. Self Refresh Abort

If MR4 OP[3] is enabled then DRAM aborts any ongoing refresh during Self Refresh exit and does not increment the internal refresh counter. Controller can issue a valid command after a delay of tXSR\_abort instead of tXSR.

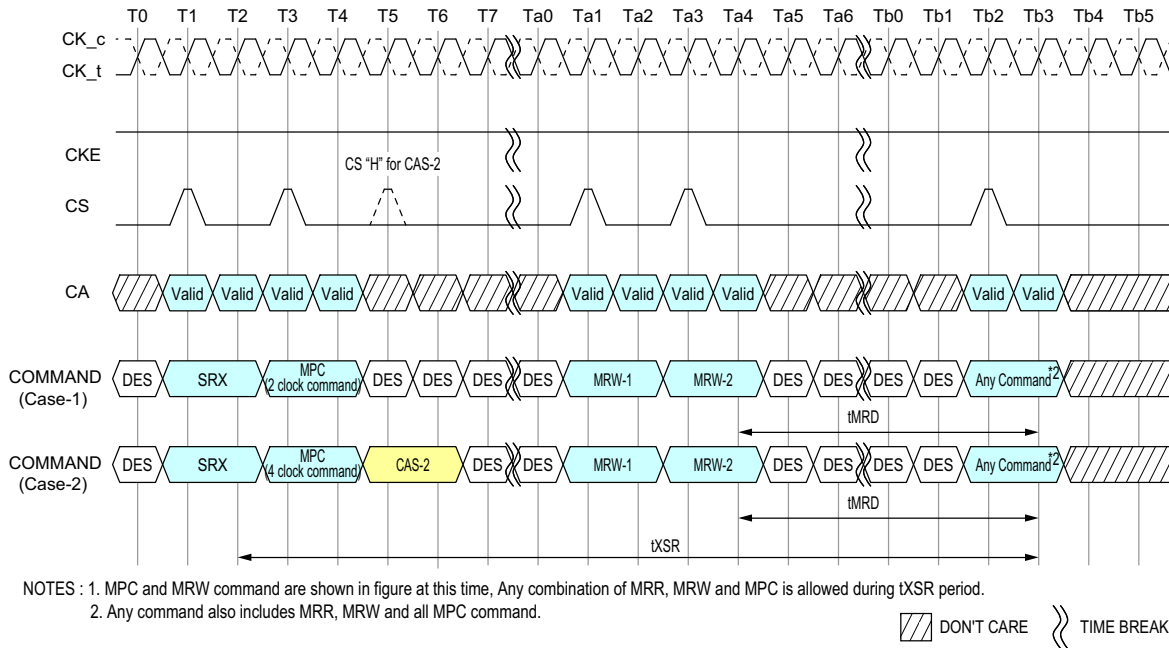
The value of tXSR\_abort(min) is defined as tRFCpb + 17.5 ns.

Upon exit from Self Refresh mode, the LPDDR4 SDRAM requires a minimum of one extra refresh (8 per bank or 1 all bank) before entry into a subsequent Self Refresh mode. This requirement remains the same irrespective of the setting of the MR bit for self refresh abort.

Self refresh abort feature is available for higher density devices starting with 12 Gb device.

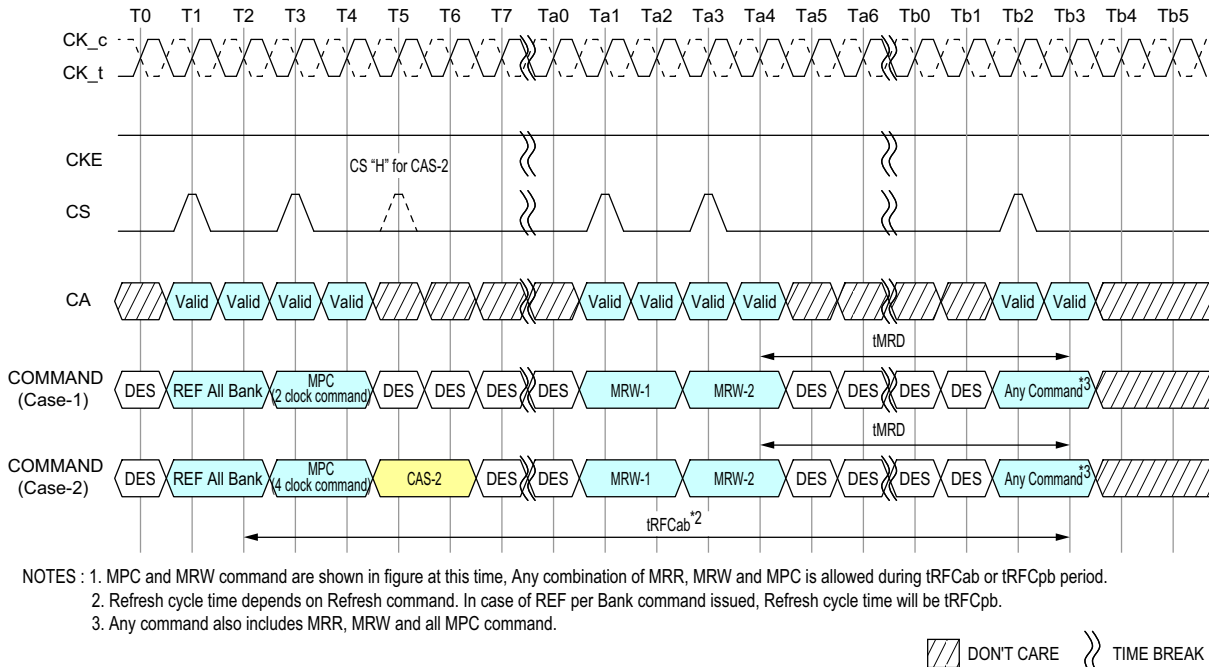
### 3.17. MRR, MRW, MPC Command during tXSR, tRFC

Mode Register Read (MRR), Mode Register Write (MRW) and Multi Purpose Command (MPC) can be issued during tXSR period.



**Figure - MRR, MRW and MPC Commands Issuing Timing during tXSR**

Mode Register Read (MRR), Mode Register Write (MRW) and Multi Purpose Command (MPC) can be issued during tRFC period.



**Figure - MRR, MRW and MPC Commands Issuing Timing during tRFC**

### 3.18. Mode Register Read (MRR) command

The Mode Register Read (MRR) command is used to read configuration and status data from the LPDDR4-SDRAM reg-

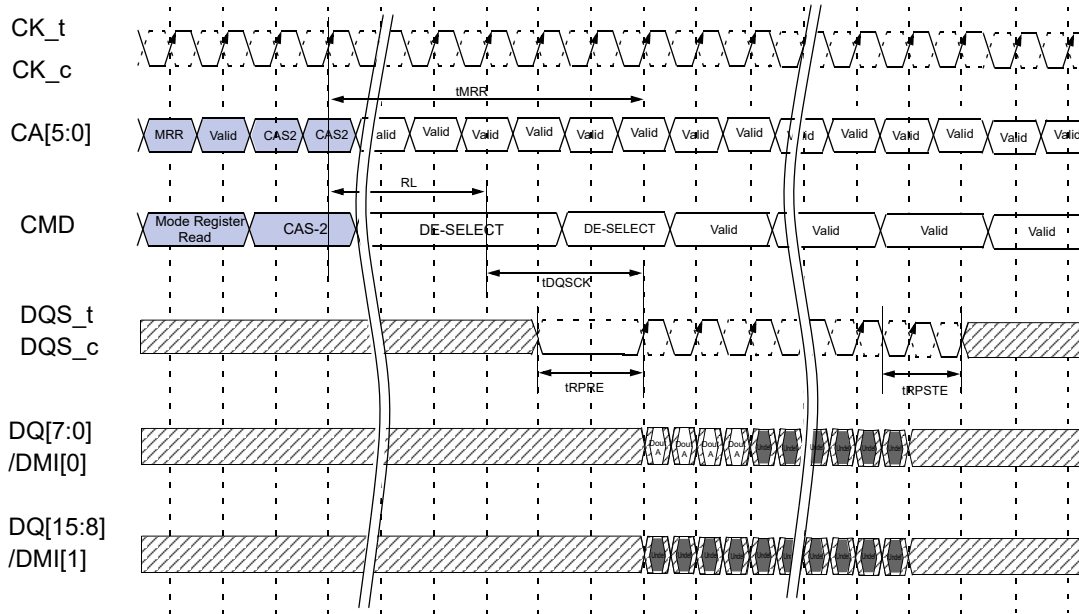
isters. The MRR command is initiated with CKE, CS and CA[5:0] in the proper state as defined by the Command Truth Table. The mode register address operands (MA[5:0]) allow the user to select one of 64 registers. The mode register contents are available on the first 4UI's data bits of DQ[7:0] after  $RL \times tCK + tDQSK + tDQSQ$  following the MRR command. Subsequent data bits contain valid but undefined content. DQS is toggled for the duration of the Mode Register READ burst. The MRR has a command burst length 16. MRR operation must not be interrupted.

BL	0	1	2	3	4	5	6	7	8	9	10	11	12	13	14	15
DQ0		OP0									V					
DQ1		OP1									V					
DQ2		OP2									V					
DQ3		OP3									V					
DQ4		OP4									V					
DQ5		OP5									V					
DQ6		OP6									V					
DQ7		OP7									V					
DMI									V							

Notes:

1. MRR data are extended to first 4 UI's for DRAM controller to sample data easily.
2. DBI may apply or may not apply during normal MRR. It's vendor specific. If read DBI is enable with MRS and vendor cannot support the DBI during MRR, DBI pin status should be low.
3. The read pre-amble and post-amble of MRR are same as normal read.

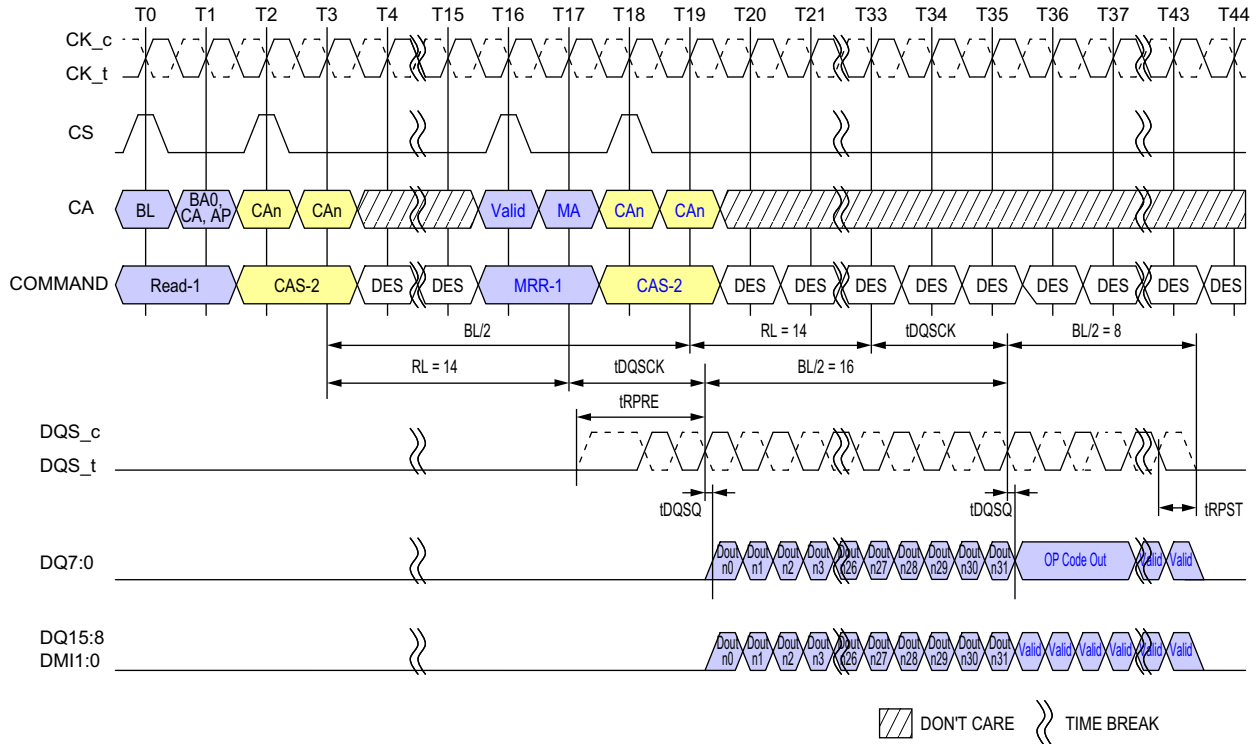
**Figure - Mode Register Read Operation**



1. Only BL=16 is supported.
2. Only De-Select is allowed during t<sub>MRR</sub> period.

### 3.18.1. MRR after Read and Write command

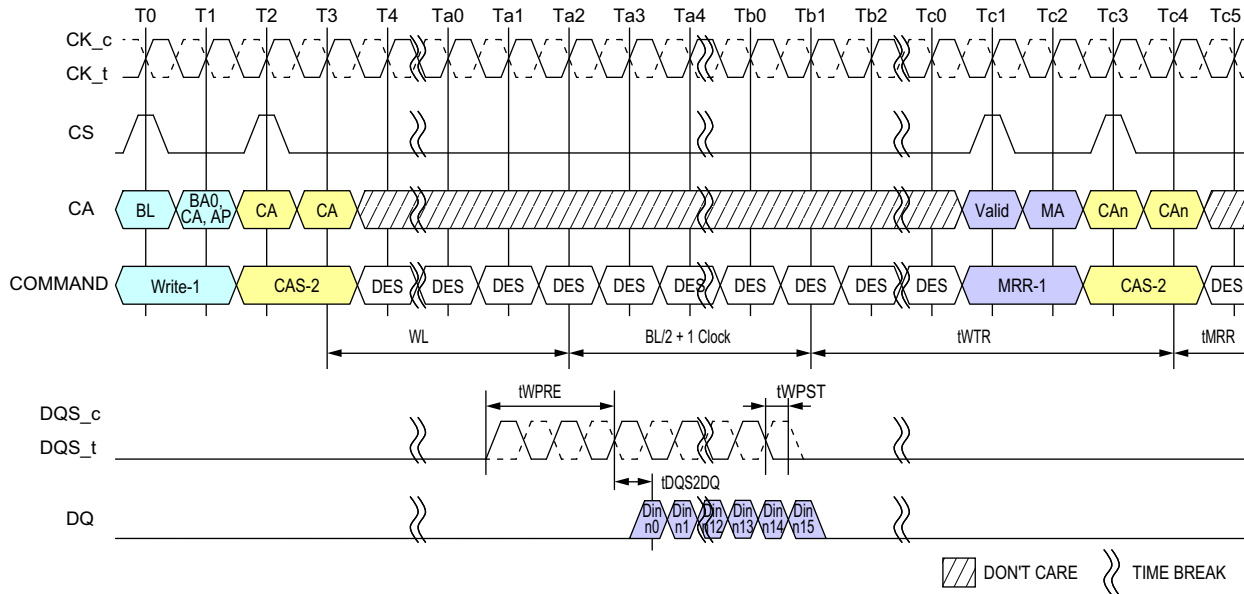
After a prior READ command, the MRR command must not be issued earlier than  $BL/2$  clock cycles, in a similar way  $WL + BL/2 + 1 + RU(tWTR/tCK)$  clock cycles after a prior Write, Write with AP, Mask Write, Mask Write with AP and MPC Write FIFO command in order to avoid the collision of Read and Write burst data on SDRAM's internal Data bus.



**Note**

1. The minimum number of clock cycles from the burst READ command to the MRR command is  $BL/2$ .
2. Read BL = 32, MRR BL = 16, RL = 14, Preamble = Toggle, Postamble =  $0.5nCK$ , DBI = Disable, DQ/DQS: VSSQ termination
3. DES commands except tMRR period are shown for ease of illustration; other commands may be valid at these times.

**Figure - Read to MRR Timing**



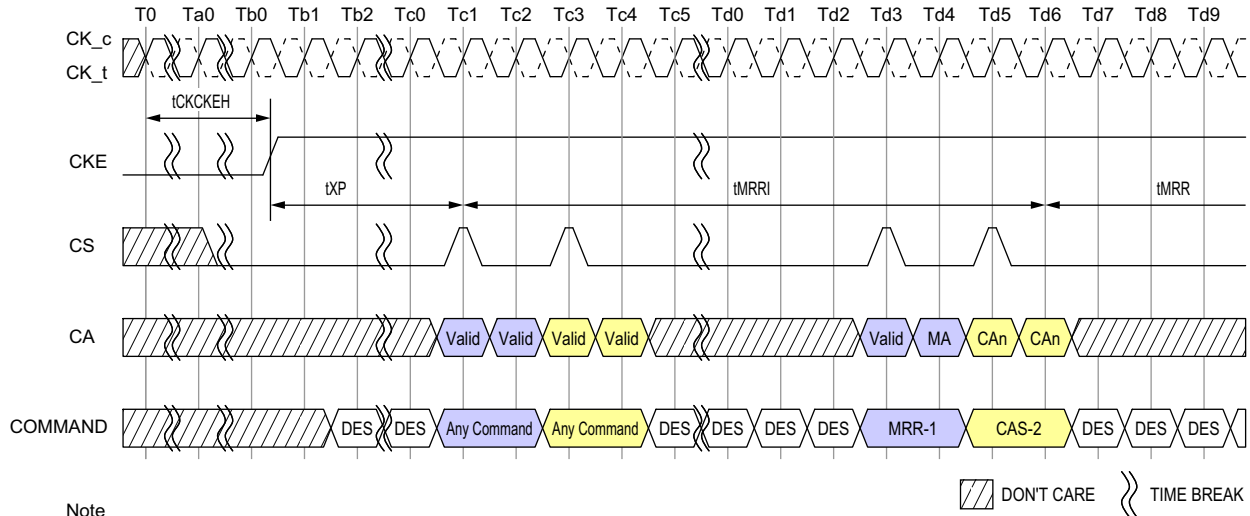
**Note**

1. Write BL=16, Write Postamble = 0.5nCK, DQ/DQS: VSSQ termination.
2. Only DES is allowed during tMRR period.
2. Din n = data-in to columnm.n.
3. The minimum number of clock cycles from the burst write command to MRR command is  $WL + BL/2 + 1 + RU(tWTR/tCK)$ .
4. tWTR starts at the rising edge of CK after the last latching edge of DQS.
5. DES commands except tMRR period are shown for ease of illustration; other commands may be valid at these times.

**Figure - Write to MRR Timing**

### 3.18.2. MRR after Power-Down Exit

Following the power-down state, an additional time,  $t_{MRRI}$ , is required prior to issuing the mode register read (MRR) command. This additional time (equivalent to  $t_{RCD}$ ) is required in order to be able to maximize power-down current savings by allowing more power-up time for the MRR data path after exit from power-down mode.



**Note**

1. Only DES is allowed during  $t_{MRR}$  period.
2. DES commands except  $t_{MRR}$  period are shown for ease of illustration; other commands may be valid at these times.

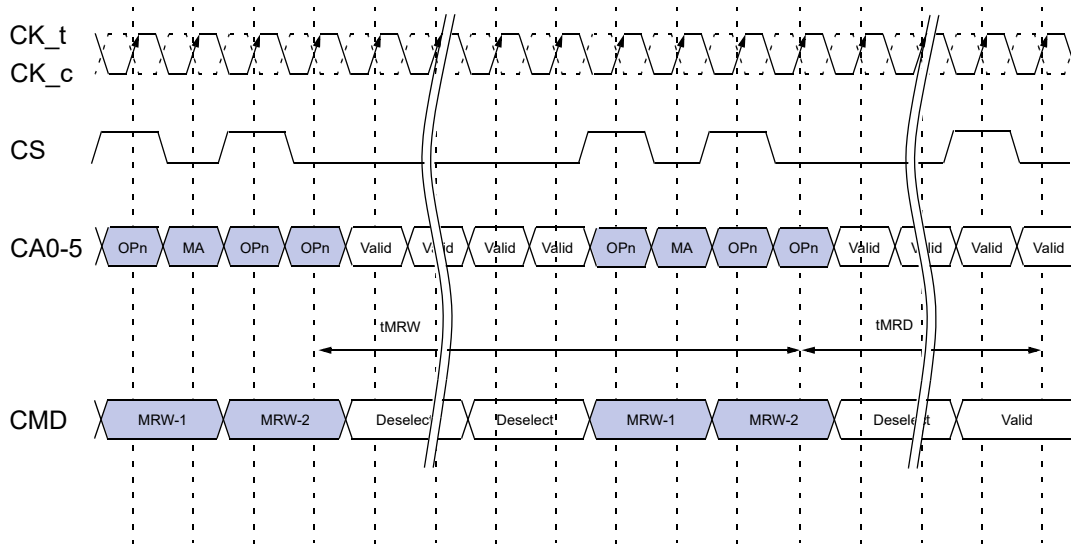
**Figure - MRR Following Power-Down**

### 3.19. Mode Register Write (MRW) command

The Mode Register Write (MRW) command is used to write configuration data to the mode registers. The MRW command is initiated by setting CKE, CS, and CA[5:0] to valid levels at a rising edge of the clock (see Command Truth Table). The mode register address and the data written to the mode registers is contained in CA[5:0] according to the Command Truth Table. The MRW command period is defined by  $t_{MRW}$ . Mode register Writes to read-only registers have no impact on the functionality of the device.



**Figure - Mode Register Write Timing**



1. Only De-select command is allowed during tMRW and tMRD periods

### 3.19.1. Mode Register Write

MRW can be issued from either a Bank-Idle or Bank-Active state. Certain restrictions may apply for MRW from an Active state.

**Table - Truth Table for Mode Register Read (MRR) and Mode Register Write (MRW)**

Current State	Command	Intermediate State	Next State
SDRAM		SDRAM	SDRAM
All Banks Idle	MRR	Mode Register Reading (All Banks Idle)	All Banks Idle
	MRW	Mode Register Writing (All Banks Idle)	All Banks Idle
Bank(s) Active	MRR	Mode Register Reading	Bank(s) Active
	MRW	Mode Register Writing	Bank(s) Active

**Table - MRR/MRW Timing Constraints : DQ ODT Disabled**

From Command	To Command	Minimum Delay between "From Command" and "To Command"	Unit	Notes
MRR	MRR	tMRR	-	
	RD/RDA	tMRR	-	
	WR/WRA/ MWR/MWRA	$RL+RU(tDQSCK(max)/tCK)+BL/2+3-WL$	nCK	
	MRW	$RL+RU(tDQSCK(max)/tCK)+BL/2+3$	nCK	

From Command	To Command	Minimum Delay between "From Command" and "To Command"	Unit	Notes
RD/RDA	MRR	BL/2	nCK	
WR/WRA/ MWR/MWRA		$WL+1+BL/2+RU(tWTR/tCK)$	nCK	
MRW		tMRD	-	
Power Down Exit		$tXP+tMRR1$	-	
MRW	RD/RDA	tMRD	-	
	WR/WRA/ MWR/MWRA	tMRD	-	
	MRW	tMRW	-	
RD/ RD FIFO/ RD DQ CAL	MRW	$RL+BL/2+RU(tDQSCkmax/tCK) +RD(tRPST) +max(RU(7.5ns/tCK),8nCK)$	nCK	
RD with Auto-Precharge		$RL+BL/2+RU(tDQSCkmax/tCK) +RD(tRPST) +max(RU(7.5ns/tCK),8nCK)+nRTP-8$	nCK	
WR/ MWR/ WR FIFO		$WL+1+BL/2+max(RU(7.5ns/tCK),8nCK)$	nCK	
WR/MWR with Auto-Precharge		$WL+1+BL/2+max(RU(7.5ns/tCK),8nCK)+nWR$	nCK	

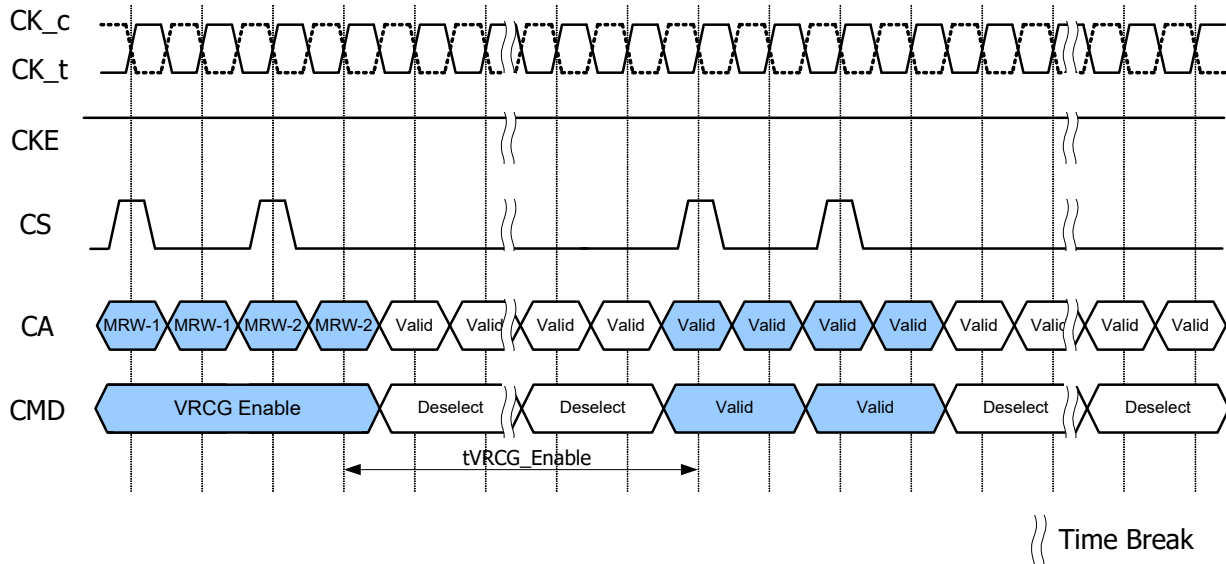
**Table - MRR/MRW Timing Constraints : DQ ODT Enabled**

From Command	To Command	Minimum Delay between "From Command" and "To Command"	Unit	Notes
MRR	MRR	Same as ODT Disable Case	-	
	RD/RDA			
	WR/WRA/ MWR/MWRA	$RL+RU(tDQSCK(max)/tCK)+BL/2+3$ $-ODT_{Lon}-RD(tODT_{on}(min)/tCK)$	nCK	
	MRW	Same as ODT Disable Case	-	
RD/RDA	MRR	Same as ODT Disable Case	-	
WR/WRA/ MWR/MWRA				
MRW				
Power Down Exit				
MRW	RD/RDA	Same as ODT Disable Case	-	
	WR/WRA/ MWR/ MWRA			
	MRW			
RD/ RD FIFO/ RD DQ CAL	MRW	Same as ODT Disable Case	-	
RD with Auto-Precharge				
WR/ MWR/ WR FIFO				
WR/MWR with Auto-Precharge				

### 3.20. Vref Current Generator (VRCG)

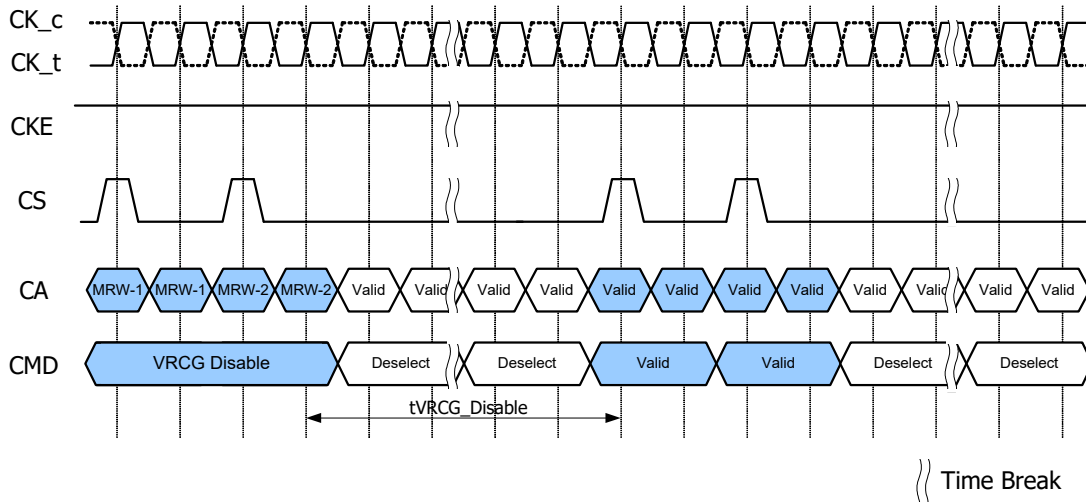
LPDDR4 SDRAM Vref current generators (VRCG) incorporate a high current mode to reduce the settling time of the internal Vref(DQ) and Vref(CA) levels during training and when changing frequency set points during operation. The high current mode is enabled by setting MR13[OP3] = 1. Only Deselect commands may be issued until tVRCG\_ENABLE is satisfied. tVRCG\_ENABLE timing is shown in figure below.

**Figure - VRCG Enable timing**



VRCG high current mode is disabled by setting MR13[OP3] = 0. Only Deselect commands may be issued until  $t_{VRCG\_DISABLE}$  is satisfied.  $t_{VRCG\_DISABLE}$  timing is shown in figure below.

**Figure - VRCG Disable timing**



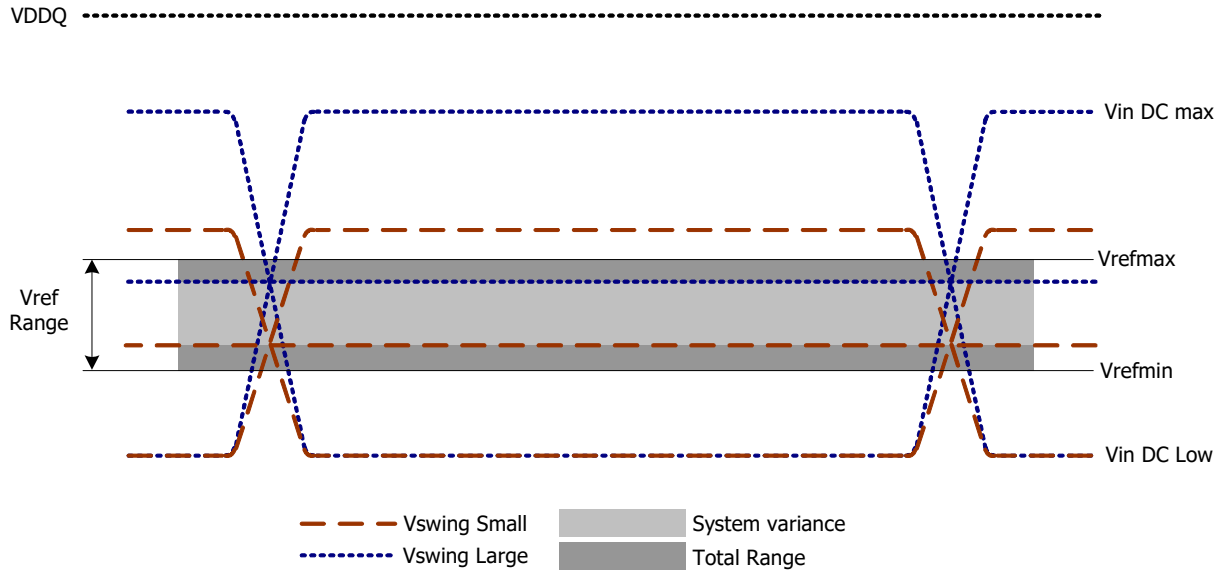
Note that LPDDR4 SDRAM devices support  $V_{ref}(CA)$  and  $V_{ref}(DQ)$  range and value changes without enabling VRCG high current mode.

### 3.21. CA Vref Training

The DRAM internal CA Vref specification parameters are voltage operating range, stepsize, Vref set tolerance, Vref step time and Vref valid level.

The voltage operating range specifies the minimum required Vref setting range for LPDDR4 DRAM devices. The minimum range is defined by Vrefmax and Vrefmin as depicted in Figure - Vref operating range (Vref.min, Vref.max).

**Figure - Vref operating range (Vref.min, Vref.max)**

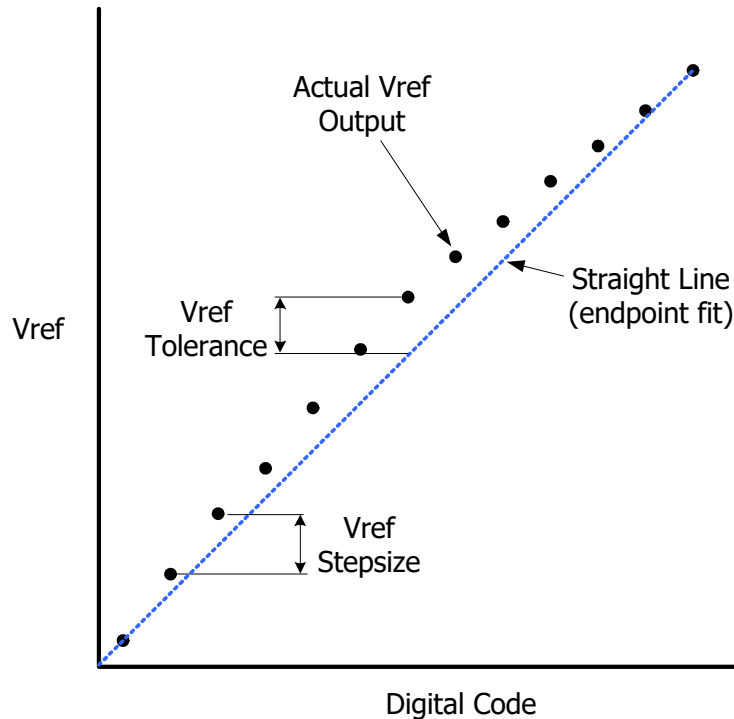


The Vref stepsize is defined as the stepsize between adjacent steps. Vref stepsize ranges from 0.5% VDDQ to 0.7% VDDQ. However, for a given design, DRAM has one value for Vref step size that falls within the range.

The Vref set tolerance is the variation in the Vref voltage from the ideal setting. This accounts for accumulated error over multiple steps. There are two ranges for Vref set tolerance uncertainty. The range of Vref set tolerance uncertainty is a function of number of steps n.

The Vref set tolerance is measured with respect to the ideal line which is based on the two endpoints. Where the endpoints are at the min and max Vref values for a specified range. An illustration depicting an example of the stepsize and Vref set tolerance is below.

**Figure - Example of Vref set tolerance (max case only shown) and stepsize**



The Vref increment/decrement step times are defined by Vref\_time-short, middle and long. The Vref\_time-short, Vref\_time-middle and Vref\_time-long is defined from TS to TE as shown in the Figure - Vref\_time for short, middle and long timing diagram below where TE is referenced to when the vref voltage is at the final DC level within the Vref valid tolerance (Vref\_val\_tol).

The Vref valid level is defined by Vref\_val tolerance to qualify the step time TE as shown in Figure - Vref\_time for short, middle and long timing diagram. This parameter is used to insure an adequate RC time constant behavior of the voltage level change after any Vref increment/decrement adjustment. This parameter is only applicable for DRAM component level validation/characterization.

Vref\_time-Short is for a single stepsize increment/decrement change in Vref voltage.

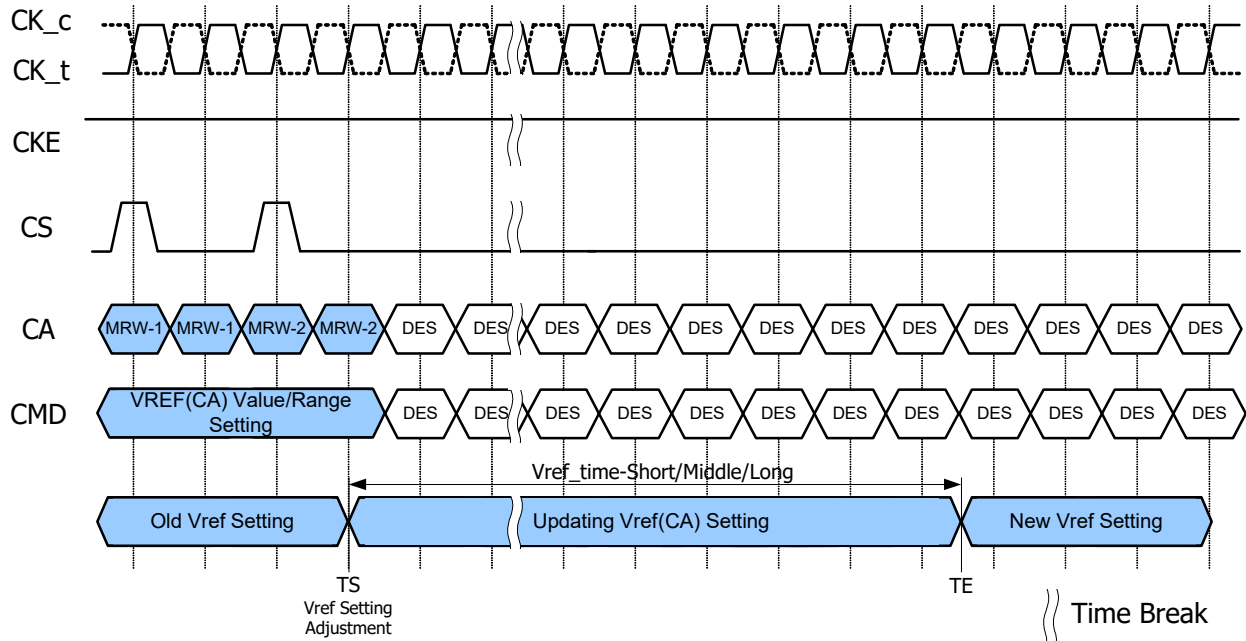
Vref\_time-Middle is at least 2 stepsizes increment/decrement change within the same VrefCA range in Vref voltage.

Vref\_time-Long is the time including up to Vrefmin to Vrefmax or Vrefmax to Vrefmin change across the VrefCA Range in Vref voltage.

TS - is referenced to MRS command clock

TE - is referenced to the Vref\_val\_tol

**Figure - Vref\_time for short, middle and long timing diagram**

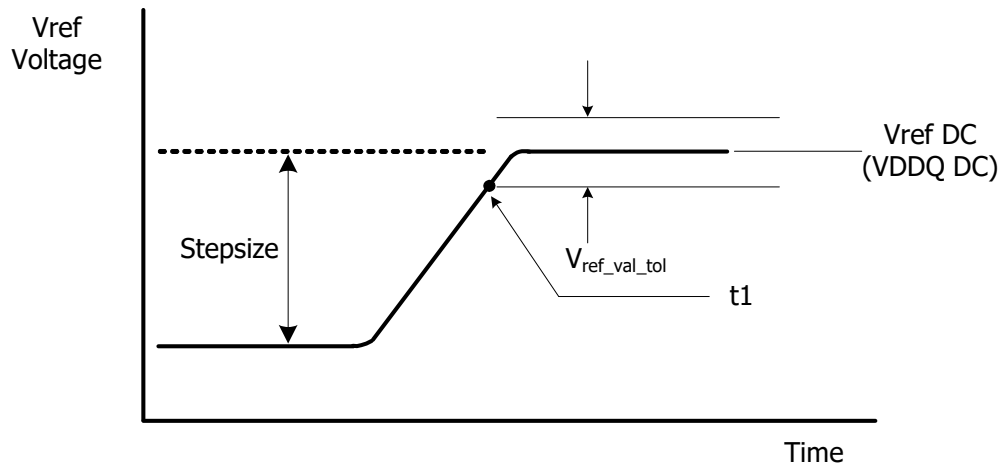


The MRW command to the mode register bits are as follows.

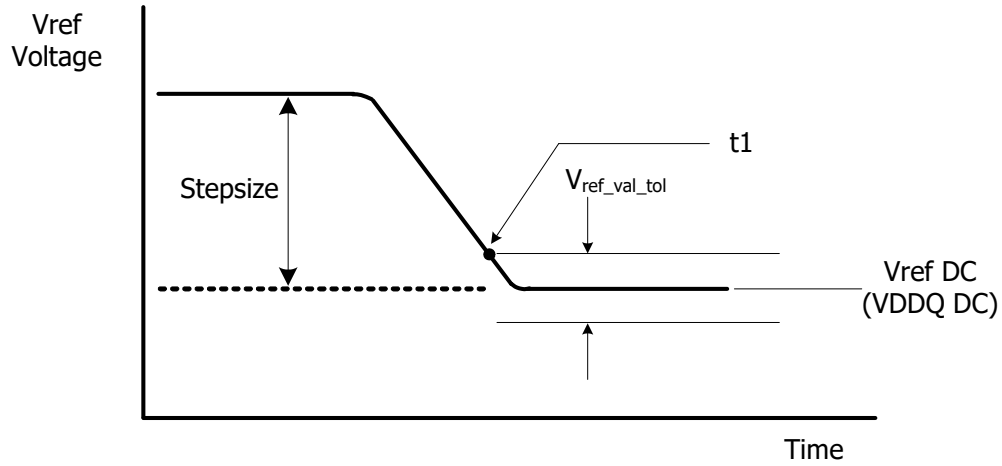
- MR12 OP[5:0] : VREF(CA) Setting
- MR12 OP[6] : VREF(CA) Range

The minimum time required between two Vref MRS commands is Vref\_time-short for single step and Vref\_time-Middle for a full voltage range step.

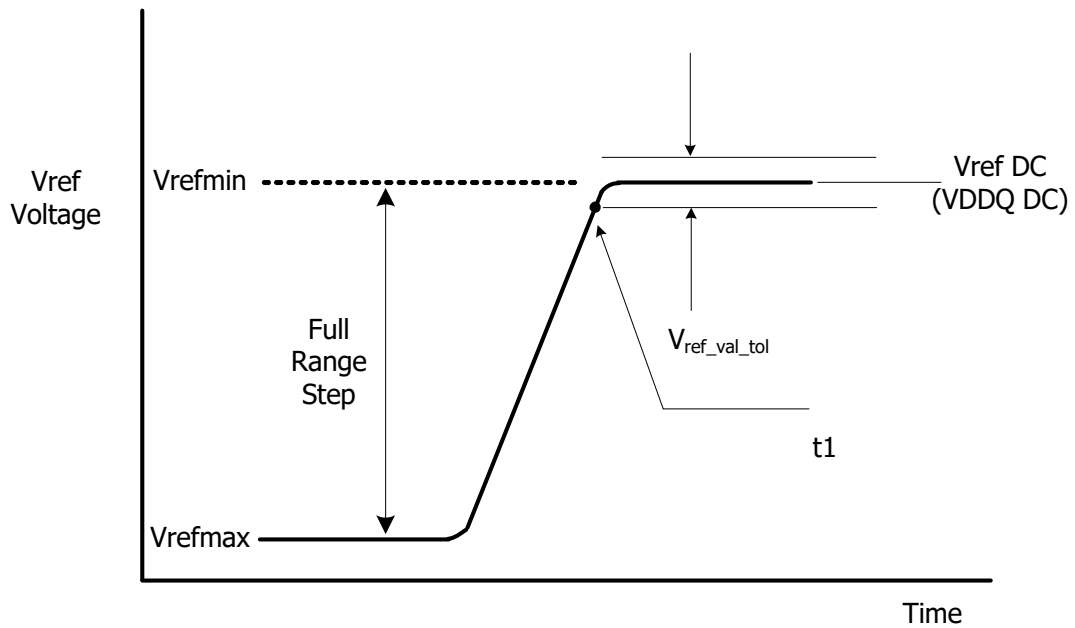
**Figure - Vref step single stepsize increment case**



**Figure - Vref step single stepsize decrement case**

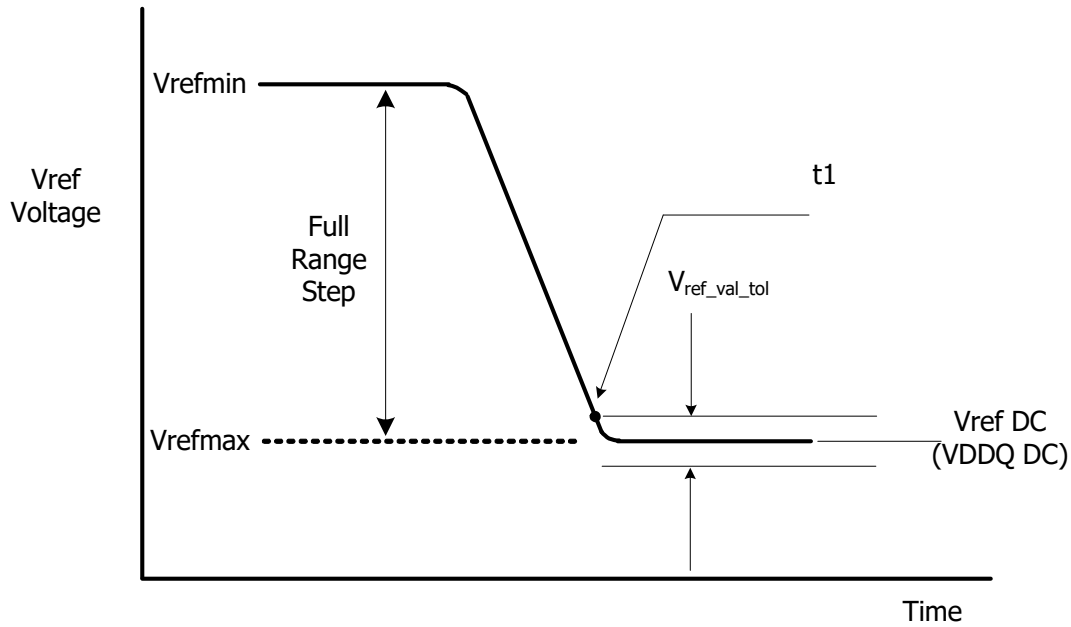


**Figure - Vref full step from Vrefmin to Vrefmax case**





**Figure - Vref full step from Vrefmax to Vrefmin case**



The table below contains the CA internal vref specifications that will be characterized at the component level for compliance. The component level characterization method is tbd.

**Table - CA Internal Vref Specifications**

Parameter	Symbol	Min.	Typ.	Max.	Unit	Notes
Vref Max operating point Range[0]	Vref_max_R0	-	-	44.9%	VDDQ	1,11
Vref Min operating point Range[0]	Vref_min_R0	15%	-	-	VDDQ	1,11
Vref Max operating point Range[1]	Vref_max_R1	-	-	62.9%	VDDQ	1,11
Vref Min operating point Range[1]	Vref_min_R1	32.9%	-	-	VDDQ	1,11
Vref Stepsize	Vref_step	0.50%	0.60%	0.70%	VDDQ	2
Vref Set Tolerance	Vref_set_tol	-11	0	11	mV	3,4,6
		-1.1	0	1.1	mV	3,5,7
Vref Step Time	Vref_time-short	-	-	100	ns	8
	Vref_time-middle	-	-	200	ns	12
	Vref_time-Long	-	-	250	ns	9
	Vref_time-weak	-	-	1	ms	13,14
Vref Valid tolerance	Vref_val_tol	-0.10%	0.00%	0.10%	VDDQ	10

Notes:

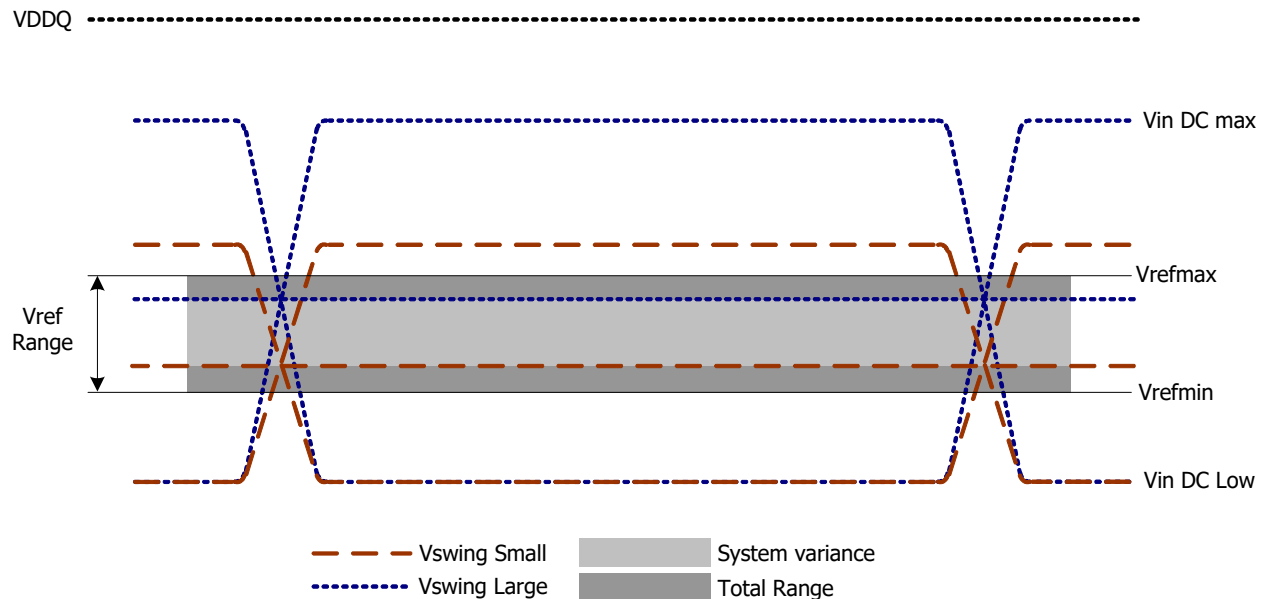
1. Vref DC voltage referenced to VDDQ\_DC.
2. Vref stepsize increment/decrement range. Vref at DC level.
3.  $Vref\_new = Vref\_old + n * Vref\_step$ ; n= number of steps; if increment use "+"; If decrement use "-".
4. The minimum value of Vref setting tolerance =  $Vref\_new - 11mV$ . The maximum value of Vref setting tolerance =  $Vref\_new + 11mV$ . For  $n > 4$
5. The minimum value of Vref setting tolerance =  $Vref\_new - 1.1mV$ . The maximum value of Vref setting tolerance =  $Vref\_new + 1.1mV$ . For  $n \leq 4$ .
6. Measured by recording the min and max values of the Vref output over the range, drawing a straight line between those points and comparing all other Vref output settings to that line.
7. Measured by recording the min and max values of the Vref output across 4 consecutive steps( $n=4$ ), drawing a straight line between those points and comparing all other Vref output settings to that line.
8. Time from MRS command to increment or decrement one step size for Vref.
9. Time from MRS command to increment or decrement Vrefmin to Vrefmax or Vrefmax to Vrefmin change across the VrefCA Range in Vref voltage.
10. Only applicable for DRAM component level test/characterization purpose. Not applicable for normal mode of operation. Vref valid is to qualify the step times which will be characterized at the component level.
11. DRAM range 0 or 1 set by MR12 OP[6].
12. Time from MRS command to increment or decrement more than one step size up a full range of Vref voltage within the same VrefCA range.
13. Applies when VRCG high current mode is not enabled, specified by MR13 OP[3] = 0.
14. Vref\_time\_weak covers all Vref(CA) Range and Value change conditions are applied to Vref\_time\_Short/Middle/Long.

### 3.22. DQ Vref Training

The DRAM internal DQ Vref specification parameters are voltage operating range, stepsize, Vref set tolerance, Vref step time and Vref valid level.

The voltage operating range specifies the minimum required Vref setting range for LPDDR4 DRAM devices. The minimum range is defined by Vrefmax and Vrefmin as depicted in Figure - Vref operating range (Vref.min, Vref.max).

**Figure - Vref operating range (Vref.min, Vref.max)**

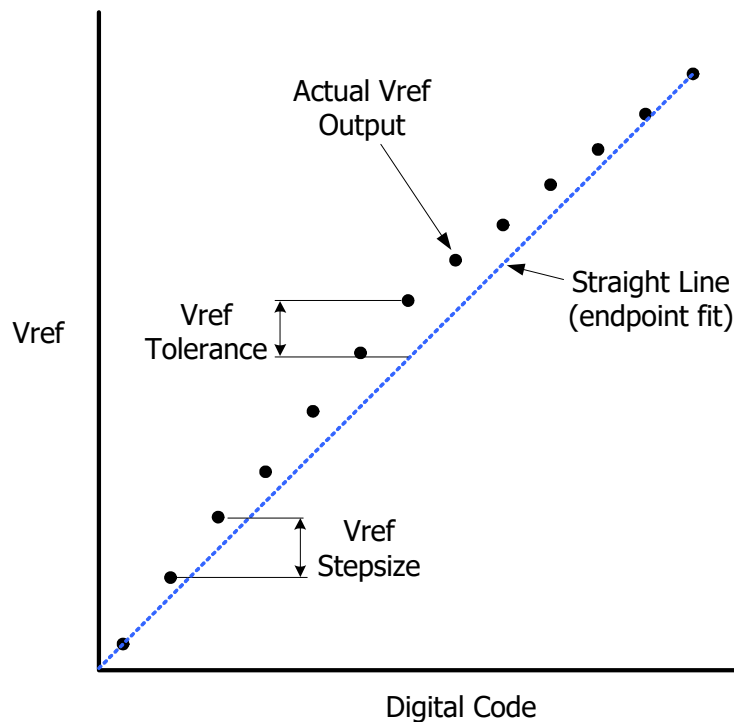


The Vref stepsize is defined as the stepsize between adjacent steps. However, for a given design, DRAM has one value for Vref step size that falls within the range.

The Vref set tolerance is the variation in the Vref voltage from the ideal setting. This accounts for accumulated error over multiple steps. There are two ranges for Vref set tolerance uncertainty. The range of Vref set tolerance uncertainty is a function of number of steps n.

The Vref set tolerance is measured with respect to the ideal line which is based on the two endpoints. Where the endpoints are at the min and max Vref values for a specified range. An illustration depicting an example of the stepsize and Vref set tolerance is below.

**Figure - Example of Vref set tolerance (max case only shown) and stepsize**



The Vref increment/decrement step times are defined by Vref\_time-short, middle and long. The Vref\_time-short, middle and Vref\_time-long is defined from TS to TE as shown in the Figure - Vref\_time for short and long timing diagram below where TE is referenced to when the vref voltage is at the final DC level within the Vref valid tolerance(Vref\_val\_tol).

The Vref valid level is defined by Vref\_val tolerance to qualify the step time TE as shown in Figure - Vref\_time for short and long timing diagram. This parameter is used to insure an adequate RC time constant behavior of the voltage level change after any Vref increment/decrement adjustment. This parameter is only applicable for DRAM component level validation/characterization.

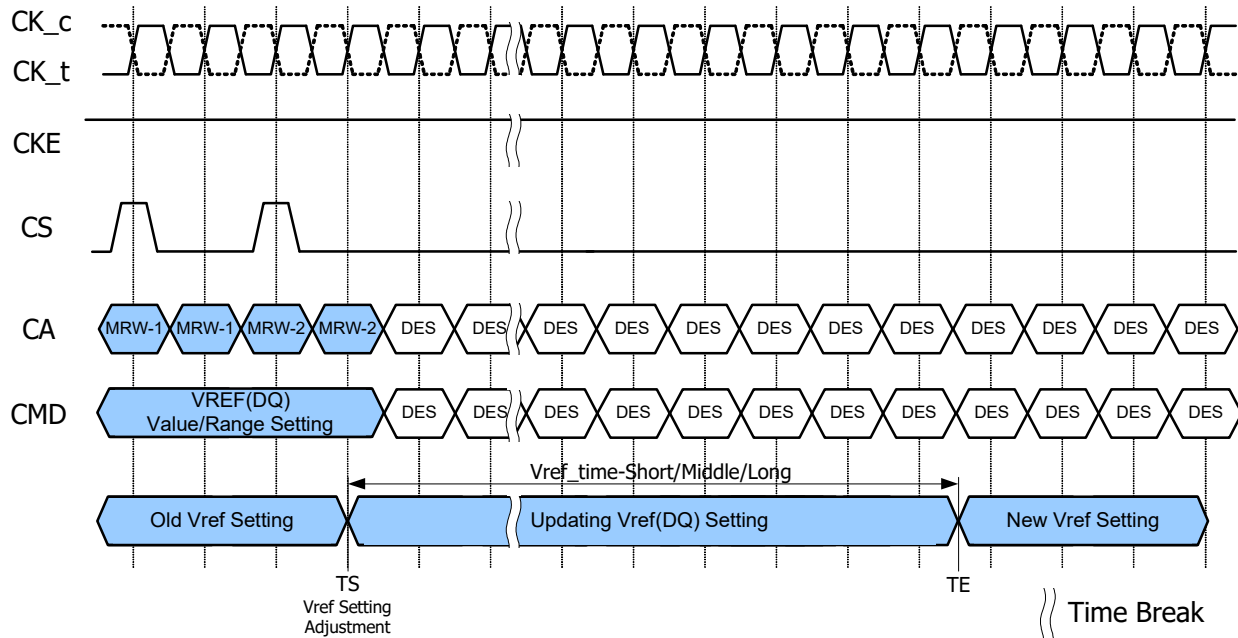
Vref\_time-Short is for a single stepsize increment/decrement change in Vref voltage.

Vref\_time-Middle is at least 2 stepsizes increment/decrement change within the same VrefDQ range in Vref voltage.  
 Vref\_time-Long is the time including up to Vrefmin to Vrefmax or Vrefmax to Vrefmin change across the VrefDQ Range in Vref voltage.

TS - is referenced to MRS command clock

TE - is referenced to the Vref\_val\_tol

**Figure - Vref\_time for short and long timing diagram**



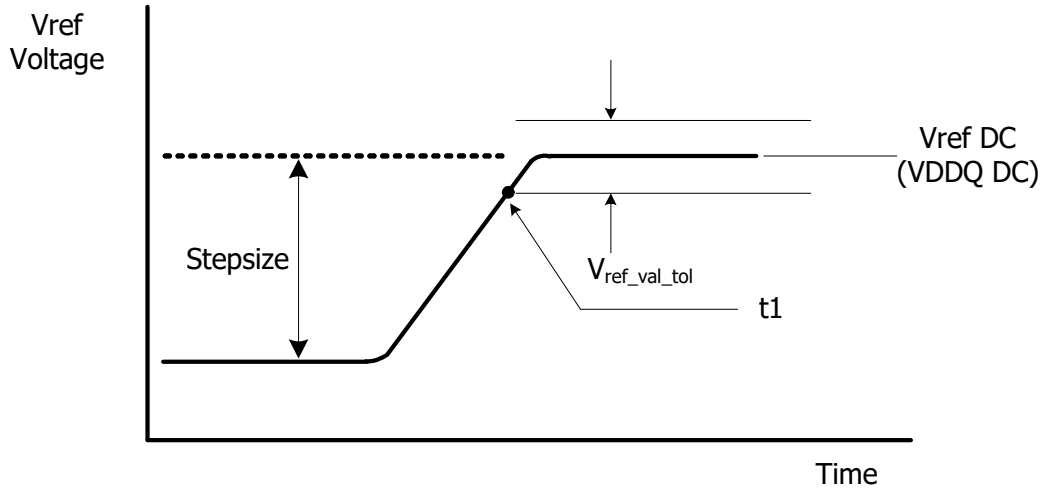
The MRW command to the mode register bits are as follows.

MR14 OP[5:0] : VREF(DQ) Setting

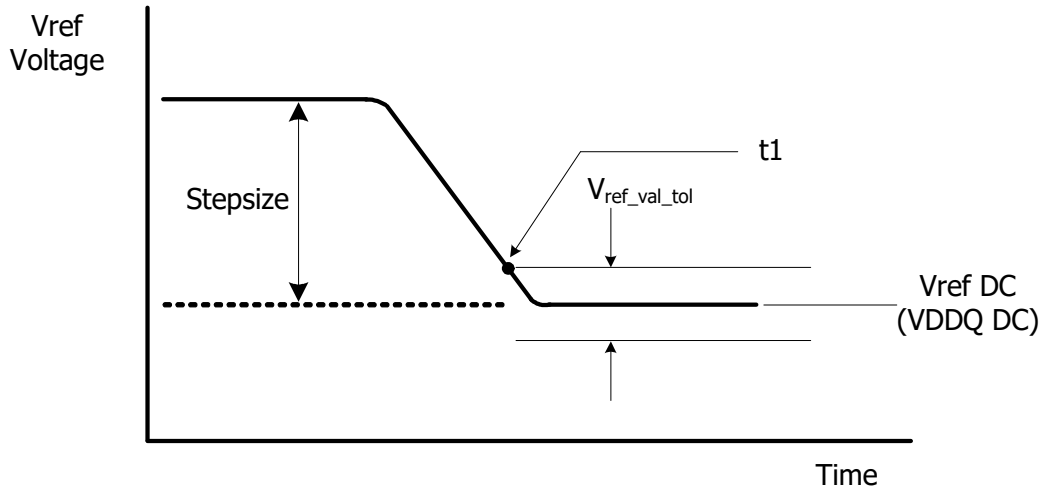
MR14 OP[6] : VREF(DQ) Range

The minimum time required between two Vref MRS commands is Vref\_time-short for single step and Vref\_time-Middle for a full voltage range step

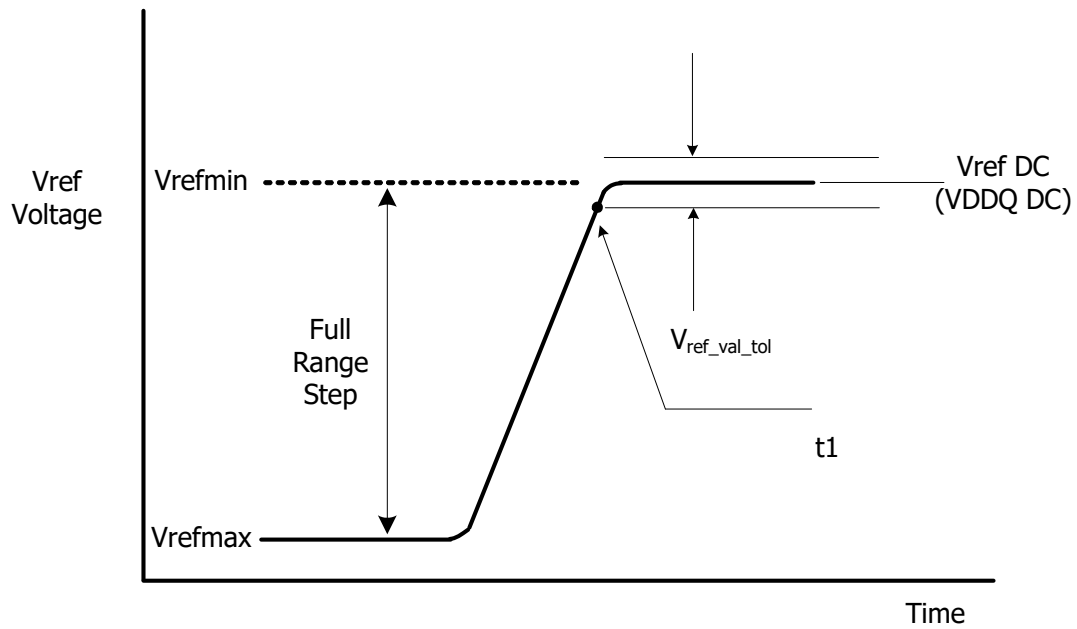
**Figure - Vref step single stepsize increment case**



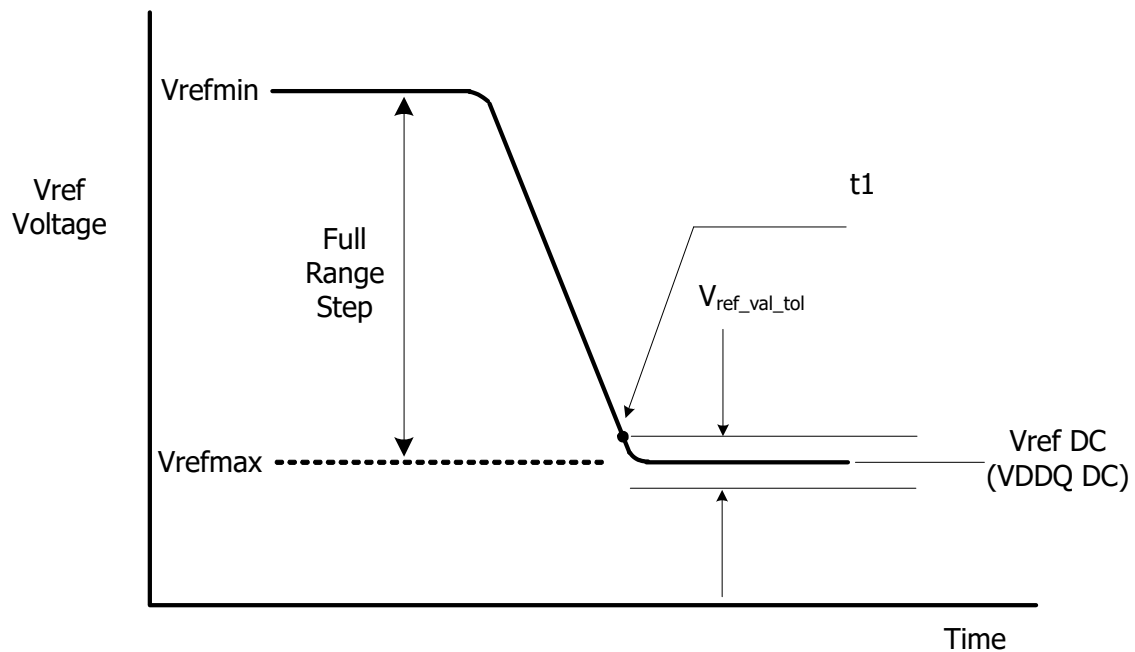
**Figure - Vref step single stepsize decrement case**



**Figure - Vref full step from Vrefmin to Vrefmax case**



**Figure - Vref full step from Vrefmax to Vrefmin case**



The table below contains the DQ internal vref specifications that will be characterized at the component level for compliance. The component level characterization method is tbd.

**Table - DQ Internal Vref Specifications**

Parameter	Symbol	Min.	Typ.	Max.	Unit	Notes
Vref Max operating point Range[0]	Vref_max_R0	-	-	44.9%	VDDQ	1,11
Vref Min operating point Range[0]	Vref_min_R0	15%	-	-	VDDQ	1,11
Vref Max operating point Range[1]	Vref_max_R1	-	-	62.9%	VDDQ	1,11
Vref Min operating point Range[1]	Vref_min_R1	32.9%	-	-	VDDQ	1,11
Vref Stepsize	Vref_step	0.50%	0.60%	0.70%	VDDQ	2
Vref Set Tolerance	Vref_set_tol	-11	0	11	mV	3,4,6
		-1.1	0	1.1	mV	3,5,7
Vref Step Time	Vref_time-short	-	-	100	ns	8
	Vref_time-Middle	-	-	200	ns	12
	Vref_time-Long	-	-	250	ns	9
	Vref_time-weak	-	-	1	ms	13,14
Vref Valid tolerance	Vref_val_tol	-0.10%	0.00%	0.10%	VDDQ	10

**Notes:**

- Vref DC voltage referenced to VDDQ\_DC.
- Vref stepsize increment/decrement range. Vref at DC level.
- $Vref_{new} = Vref_{old} + n * Vref_{step}$ ; n= number of steps; if increment use "+"; If decrement use "-".
- The minimum value of Vref setting tolerance =  $Vref_{new} - 11mV$ . The maximum value of Vref setting tolerance =  $Vref_{new} + 11mV$ . For  $n > 4$ .
- The minimum value of Vref setting tolerance =  $Vref_{new} - 1.1mV$ . The maximum value of Vref setting tolerance =  $Vref_{new} + 1.1mV$ . For  $n \leq 4$ .
- Measured by recording the min and max values of the Vref output over the range, drawing a straight line between those points and comparing all other Vref output settings to that line.
- Measured by recording the min and max values of the Vref output across 4 consecutive steps( $n=4$ ), drawing a straight line between those points and comparing all other Vref output settings to that line.
- Time from MRS command to increment or decrement one step size for Vref.
- Time from MRS command to increment or decrement Vrefmin to Vrefmax or Vrefmax to Vrefmin change across the VrefDQ Range in Vref voltage.
- Only applicable for DRAM component level test/characterization purpose. Not applicable for normal mode of operation. Vref valid is to qualify the step times which will be characterized at the component level.
- DRAM range 0 or 1 set by MR14 OP[6].
- Time from MRS command to increment or decrement more than one step size up to a full range of Vref voltage within the same VrefDQ range.
- Applies when VRCG high current mode is not enabled, specified by MR13[OP3] = 0.
- Vref\_time\_weak covers all Vref(DQ) Range and Value change conditions are applied to Vref\_time\_Short/Middle/Long.

### 3.23. Command Bus Training

The LPDDR4-SDRAM command bus must be trained before enabling termination for high-frequency operation. LPDDR4 provides an internal VREF(ca) that defaults to a level suitable for un-terminated, low-frequency operation, but the VREF(ca) must be trained to achieve suitable receiver voltage margin for terminated, high-frequency operation. The training mode described here centers the internal VREF(ca) in the CA data eye and at the same time allows for timing adjustments of the CS and CA signals to meet setup/hold requirements. Because it can be difficult to capture commands prior to training the CA inputs, the training mode described here uses a minimum of external commands to enter, train, and exit the Command Bus Training mode.

Note: it is up to the system designer to determine what constitutes "low-frequency" and "high-frequency" based on the

capabilities of the system. Low-frequency should then be defined as an operating frequency in which the system can reliably communicate with the SDRAM before Command Bus Training is executed.

The LPDDR4-SDRAM die has a bond-pad (ODT-CA) for multi-rank operation. In a multi-rank system, the terminating rank should be trained first, followed by the non-terminating rank(s). See the ODT section for more information.

The LPDDR4-SDRAM uses Frequency Set-Points to enable multiple operating settings for the die. The LPDDR4-SDRAM defaults to FSP-OP[0] at power-up, which has the default settings to operate in un-terminated, low-frequency environments. Prior to training, the mode register settings should be configured by setting MR13 OP[6]=1B (FSP-WR[1]) and setting all other mode register bits for FSP-OP[1] to the desired settings for high-frequency operation. Prior to entering Command Bus Training, the SDRAM will be operating from FSP-OP[x]. Upon Command Bus Training entry when CKE is driven LOW, the LPDDR4-SDRAM will automatically switch to the alternate FSP register set (FSP-OP[y]) and use the alternate register settings during training (See note 6 in Figure - Entering Command Bus Training Mode and CA Training Pattern Input and Output with VrefCA Value Update for more information on FSP-OP register sets). Upon training exit when CKE is driven HIGH, the LPDDR4-SDRAM will automatically switch back to the original FSP register set (FSP-OP[x]), returning to the “known-good” state that was operating prior to training. The training values for VREF(ca) are not retained by the DRAM in FSP-OP[y] registers, and must be written to the registers after training exit.

1. To enter Command Bus Training mode, issue a MRW-1 command followed by a MRW-2 command to set MR13 OP[0]=1B (Command Bus Training Mode Enabled).

2. After time tMRD, CKE may be set LOW, causing the LPDDR4-SDRAM to switch from FSP-OP[x] to FSP-OP[y], and completing the entry into Command Bus Training mode.

A status of DQS\_t, DQS\_c, DQ and DMI are as follows, and DQ ODT state will be followed Frequency Set Point function except output pins.

- DQS\_t[0], DQS\_c[0] become input pins for capturing DQ[6:0] levels by its toggling.
- DQ[5:0] become input pins for setting VREF(ca) Level.
- DQ[6] becomes a input pin for setting VREF(ca) Range.
- DQ[7] and DMI[0] become input pins and their input level is Valid level or floating, either way is fine.
- DQ[13:8] become output pins to feedback its capturing value via command bus by CS signal.
- DQS\_t[1], DQS\_c[1], DMI[1] and DQ[15:14] become output pins or disable, it means that SDRAM may drive to a valid level or left floating.

3. At time tCAENT later, LPDDR4 SDRAM can accept to change its VREF(ca) Range and Value using input signals of DQS\_t[0], DQS\_c[0] and DQ[6:0] from existing value that’s setting via MR12 OP[6:0]. The mapping between MR12 OP code and DQ signals is shown in the table below. At least one Vref CA setting is required before proceed to next training steps.

**Table - Mapping of MR12 OP Code and DQ Numbers**

	Mapping						
MR12 OP code	OP6	OP5	OP4	OP3	OP2	OP1	OP0
DQ Number	DQ6	DQ5	DQ4	DQ3	DQ2	DQ1	DQ0

4. The new VREF(ca) value must “settle” for time tVREF\_LONG before attempting to latch CA information.

5. To verify that the receiver has the correct VREF(ca) setting and to further train the CA eye relative to clock (CK),



values latched at the receiver on the CA bus are asynchronously output to the DQ bus.

6. To exit Command Bus Training mode, drive CKE HIGH, and after time  $t_{VREF\_LONG}$  issue the MRW-1 command followed by the MRW-2 command to set MR13 OP[0]=0B. After time  $t_{MRW}$  the LPDDR4-SDRAM is ready for normal operation. After training exit the LPDDR4-SDRAM will automatically switch back to the FSP-OP registers that were in use prior to training.

Command Bus Training may be executed from IDLE, or Self Refresh states. When executing CBT within the Self Refresh state, the SDRAM must not be a power down state (i.e. CKE must be HIGH prior to training entry). Command Bus Training entry and exit is the same, regardless of the SDRAM state from which CBT is initiated.

### 3.23.0.1. Training Sequence for single-rank systems:

Note that an example shown here is assuming an initial low-frequency, no-terminating operating point, training a high-frequency, terminating operating point. The **green text is low-frequency**, **magenta text is high-frequency**. Any operating point may be trained from any known good operating point.

1. Set MR13 OP[6]=1B to enable writing to Frequency Set Point 'y' (FSP-WR[y]) (or FSP-OP[x], See note).
2. Write FSP-WR[y] (or FSP-WR[x]) registers for all channels to set up high-frequency operating parameters.
3. Issue MRW-1 and MRW-2 commands to enter Command Bus Training mode.
4. Drive CKE LOW, **and change CK frequency to the high-frequency operating point.**
5. **Perform Command Bus Training (VREFca, CS, and CA).**
6. **Exit training by driving CKE HIGH**, a change CK frequency to the low-frequency operating point prior to driving CKE HIGH, then issue MRW-1 and MRW-2 commands. When CKE is driven HIGH, the SDRAM will automatically switch back to the FSP-OP registers that were in use prior to training (i.e. trained values are not retained by the SDRAM).
7. Write the trained values to FSP-WR[y] (or FSP-WR[x]) by issuing MRW-1 and MRW-2 commands to the SDRAM and setting all applicable mode register parameters.
8. Issue MRW-1 and MRW-2 commands to switch to FSP-OP[y] (or FSP-OP[x]), to turn on termination, **and change CK frequency to the high-frequency operating point. At this point the Command Bus is trained and you may proceed to other training or normal operation.**

### 3.23.0.2. Training Sequence for multi-rank systems:

(Example shown here is assuming an initial low-frequency operating point, training a high-frequency operating point. The **green text is low-frequency**, **magenta text is high-frequency**. Any operating point may be trained from any known good operating point)

1. Set MR13 OP[6]=1B to enable writing to Frequency Set Point 'y' (FSP-WR[y]) (or FSP-WR[x], See Note).
2. Write FSP-WR[y] (or FSP-WR[x]) registers for all channels and ranks to set up high-frequency operating parameters.
3. Read MR0 OP[7] on all channels and ranks to determine which die are terminating, signified by MR0 OP[7]=1B.
4. Issue MRW-1 and MRW-2 commands to enter Command Bus Training mode on the terminating rank.
5. Drive CKE LOW on the terminating rank (or all ranks), **and change CK frequency to the high-frequency operating point.**
6. **Perform Command Bus Training on the terminating rank (VREFca, CS, and CA).**
7. **Exit training by driving CKE HIGH**, change CK frequency to the low-frequency operating point, and issue MRW-1 and MRW-2 commands to write the trained values to FSP-WR[y] (or FSP-WR[x]). When CKE is driven HIGH, the SDRAM will automatically switch back to the FSP-OP registers that were in use prior to training (i.e. trained values are not retained by the SDRAM).

8. Issue MRW-1 and MRW-2 command to enter training mode on the non-terminating rank (but keep CKE HIGH)
9. Issue MRW-1 and MRW-2 commands to switch the terminating rank to FSP-OP[y] (or FSP-OP[x]), to turn on termination, and change CK frequency to the highfrequency operating point.
10. Drive CKE LOW on the non-terminating (or all) ranks. The non-terminating rank(s) will now be using FSP-OP[y] (or FSP-OP[x]).
11. Perform Command Bus Training on the non-terminating rank (VREFca, CS, and CA).
12. Issue MRW-1 and MRW-2 commands to switch the terminating rank to FSP-OP[x] (or FSP-OP[y]) to turn off termination.
13. Exit training by driving CKE HIGH on the non-terminating rank, change CK frequency to the low-frequency operating point, and issue MRW-1 and MRW-2 commands. When CKE is driven HIGH, the SDRAM will automatically switch back to the FSP-OP registers that were in use prior to training (i.e. trained values are not retained by the SDRAM).
14. Write the trained values to FSP-WR[y] (or FSP-WR[x]) by issuing MRW-1 and MRW-2 commands to the SDRAM and setting all applicable mode register parameters.
15. Issue MRW-1 and MRW-2 commands to switch the terminating rank to FSP-OP[y] (or FSP-OP[x]), to turn on termination, and change CK frequency to the highfrequency operating point. At this point the Command Bus is trained for both ranks and you may proceed to other training or normal operation.

### 3.23.0.3. Relation between CA input pin and DQ output pin

The relation between CA input pin and DQ out pin is shown in the following table.

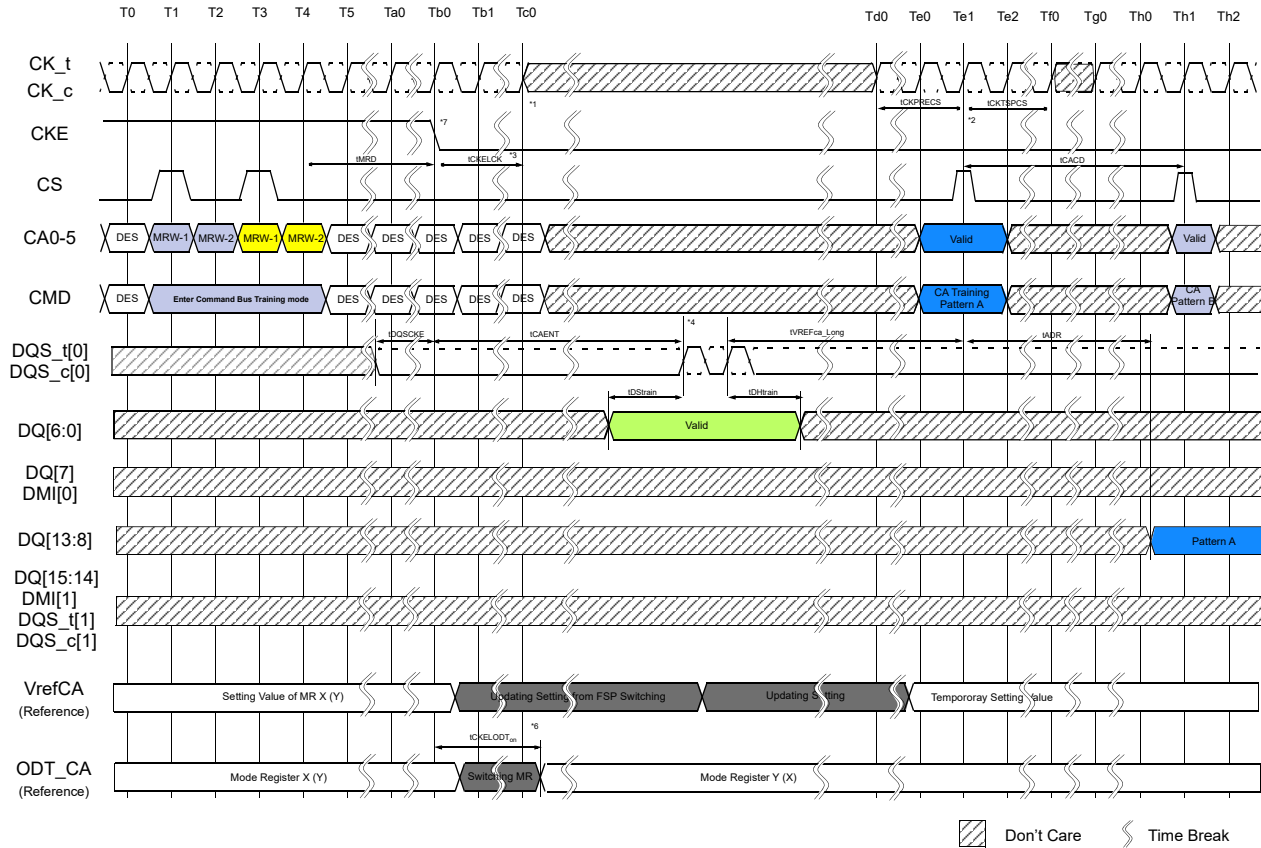
**Table - Mapping of CA input pin to DQ ouput pin**

	Mapping					
CA Numbe.	CA5	CA4	CA3	CA2	CA1	CA0
DQ Number	DQ13	DQ12	DQ11	DQ10	DQ9	DQ8

### 3.23.0.4. Timing Diagram

The basic timing diagrams of Command Bus Training are shown in following figures.

**Figure - Entering Command Bus Training Mode and CA Training Pattern Input and Output with VrefCA Value Update**



**Notes:**

1. After tCKELCK clock can be stopped or frequency changed any time.
2. The input clock condition should be satisfied tCKPRECS and tCKPSTCS.
3. Continue to Drive CK and Hold CA & CS pins low until tCKELCK after CKE is low (which disables command decoding).
4. DRAM may or may not capture first rising/falling edge of DQS\_t/c due to an unstable first rising edge. Hence provide at least consecutive 2 pulses of DQS signal input is required in every DQS input signal at capturing DQ[6:0] signals.  
The captured value of DQ[6:0] signal level by each DQS edges are overwritten at any time and the DRAM updates its VREFca setting of MR12 temporary after time tVREFca\_Long.
5. tVREF\_LONG may be reduced to tVREF\_SHORT if the following conditions are met: 1) The new Vref setting is a single step above or below the old Vref setting, and 2) The DQS pulses a single time, or the new Vref setting value on DQ[6:0] is static and meets tDSTRain/tDHTRain for every DQS pulse applied.
6. When CKE is driven LOW, the SDRAM will switch its FSP-OP registers to use the alternate (i.e. non-active) set. Example: If the SDRAM is currently using FSP-OP[0], then it will switch to FSP-OP[1] when CKE is driven LOW. All operating parameters should be written to the alternate mode registers before entering Command Bus Training to ensure that ODT settings, RL/WL/nWR setting, etc., are set to the correct values. If the alternate FSP-OP has ODT\_CA disabled then termination will not enable in CA Bus Training mode. If the ODT\_CA pad is bonded to Vss or floating, ODT\_CA termination will never enable for that die.
7. When CKE is low in Command Bus Training mode, the LPDDR4-SDRAM will change operation to the alternate FSP, i.e. the inverse of the FSP programmed in the FSP-OP mode register.

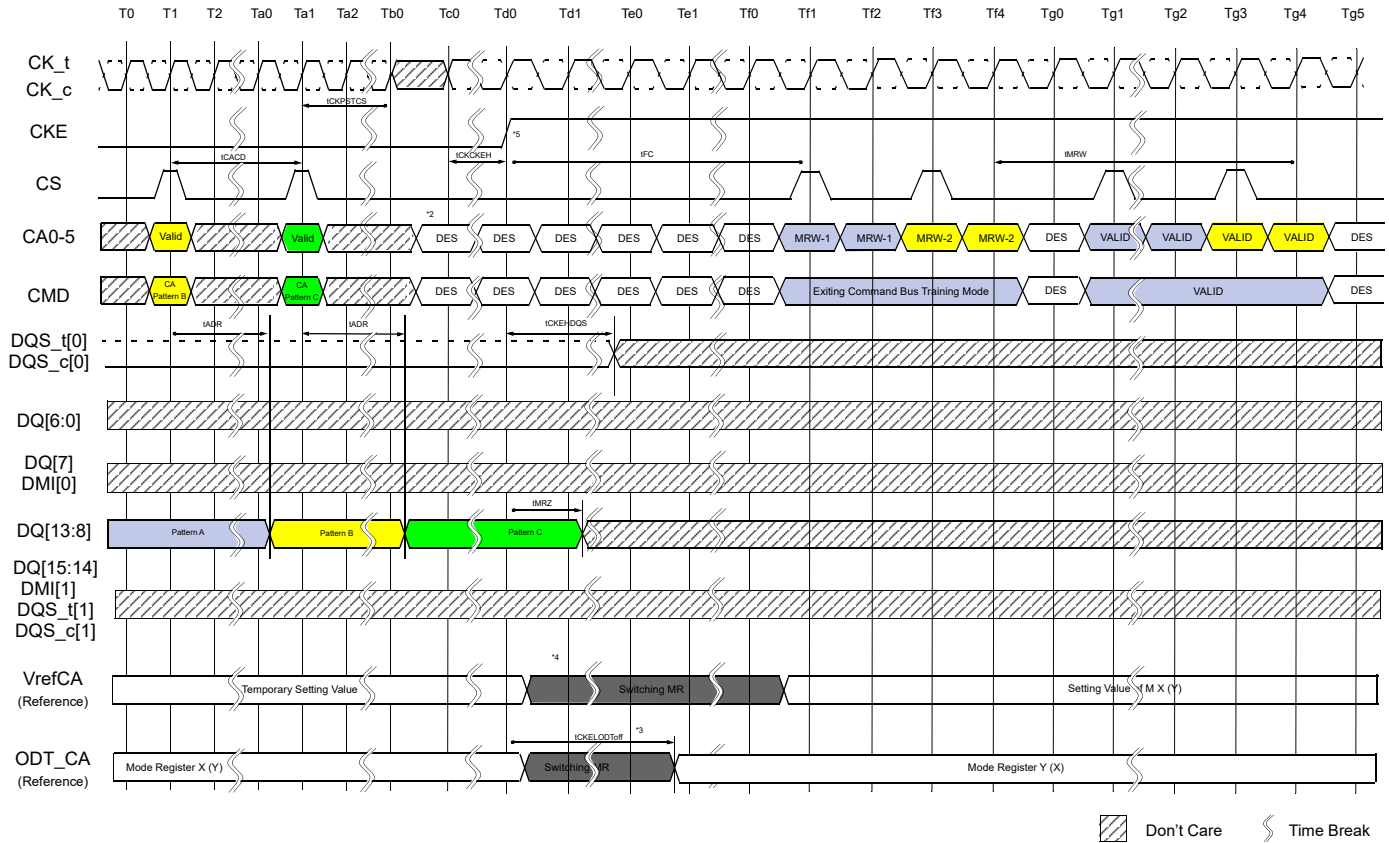
**Figure - Consecutive VrefCA Value Update**



**Notes:**

1. After tCKELCK clock can be stopped or frequency changed any time.
2. The input clock condition should be satisfied tCKPRECS.
3. Continue to Drive CK and Hold CA & CS pins low until tCKELCK after CKE is low (which disables command decoding).
4. DRAM may or may not capture first rising/falling edge of DQS\_t/c due to an unstable first rising edge. Hence provide at least consecutive 2 pulses of DQS signal input is required in every DQS input signal at capturing DQ6:0 signals.  
The captured value of DQ[6:0] signal level by each DQS edges are overwritten at any time and the DRAM updates its VREFca setting of MR12 temporary after time tVREFca\_Long.
5. tVREF\_LONG may be reduced to tVREF\_SHORT if the following conditions are met: 1) The new Vref setting is a single step above or below the old Vref setting, and 2) The DQS pulses a single time, or the new Vref setting value on DQ[6:0] is static and meets tDSTRAIN/tDHTRAIN for every DQS pulse applied.
6. When CKE is driven LOW, the SDRAM will switch its FSP-OP registers to use the alternate (i.e. non-active) set. Example: If the SDRAM is currently using FSP-OP[0], then it will switch to FSP-OP[1] when CKE is driven LOW. All operating parameters should be written to the alternate mode registers before entering Command Bus Training to ensure that ODT settings, RL/WL/nWR setting, etc., are set to the correct values. If the alternate FSP-OP has ODT\_CA disabled then termination will not enable in CA Bus Training mode. If the ODT\_CA pad is bonded to Vss or floating, ODT\_CA termination will never enable for that die.
7. When CKE is driven low in Command Bus Training mode, the LPDDR4-SDRAM will change operation to the alternate FSP, i.e. the inverse of the FSP programmed in the FSP-OP mode register.

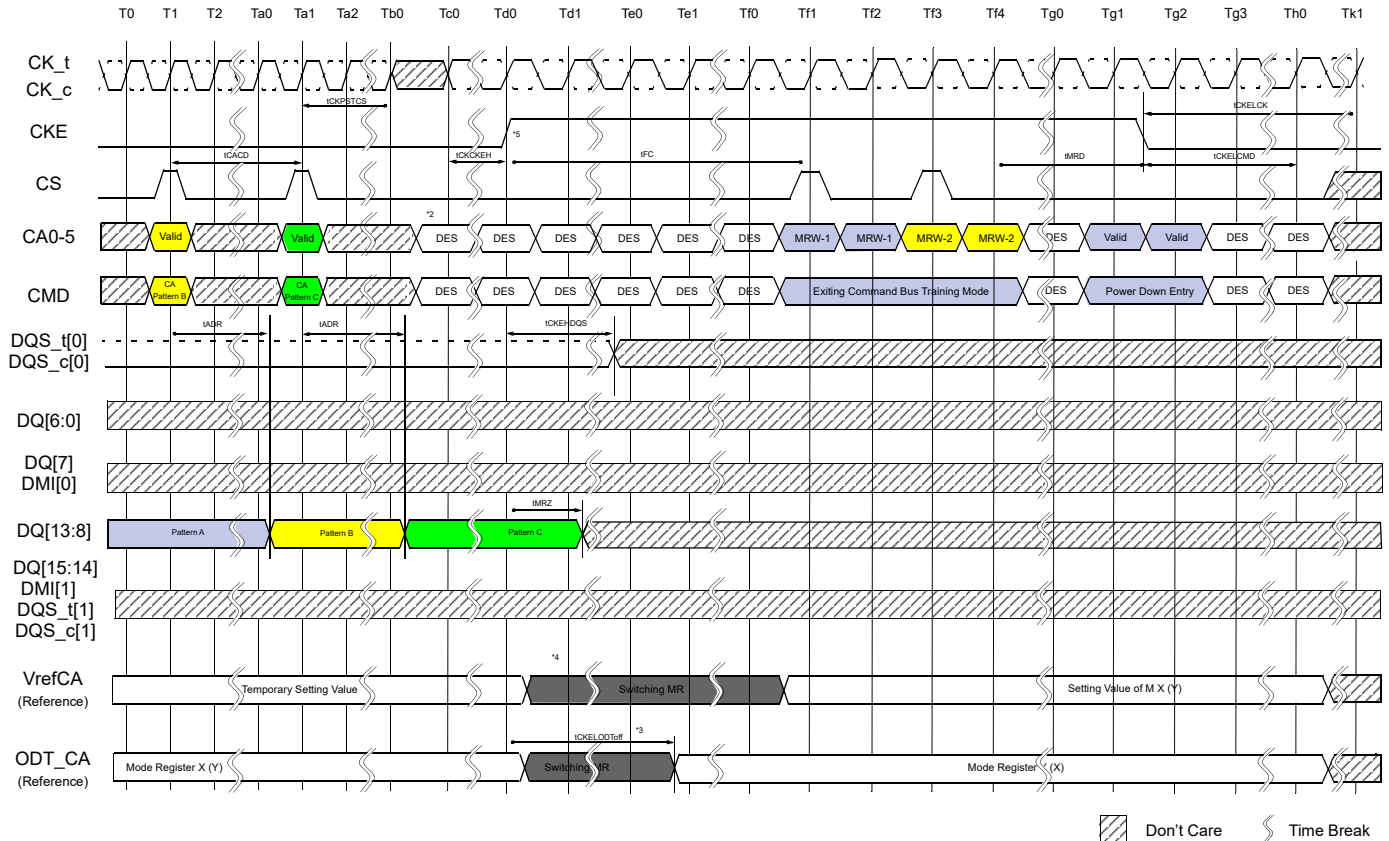
**Figure - Exiting Command Bus Training Mode with Valid Command**



**Notes:**

1. Clock can be stopped or frequency changed any time before  $t_{CKCKEH}$ . CK must meet  $t_{CKCKEH}$  before CKE is driven high. When CKE is driven high the clock frequency must be returned to the original frequency (the frequency corresponding to the FSP at which Command Bus Training mode was entered)
2. CS and CA[5:0] must be Deselect (all low)  $t_{CKCKEH}$  before CKE is driven high.
3. When CKE is driven high, the SDRAM's ODT\_CA will revert to the state/value defined by FSP-OP prior to Command Bus Training mode entry, i.e. the original frequency set point (FSP-OP, MR13-OP[7]).  
Example: If the SDRAM was using FSP-OP[1] for training, then it will switch to FSP-OP[0] when CKE is driven HIGH.
4. Training values are not retained by the SDRAM, and must be written to the FSP-OP register set before returning to operation at the trained frequency.  
Example: VREF(ca) will return to the value programmed in the original set point.
5. When CKE is driven high the LPDDR4-SDRAM will revert to the FSP in operation when Command Bus Training mode was entered.

**Figure - Exiting Command Bus Training Mode with Power Down Entry**



**Notes:**

1. Clock can be stopped or frequency changed any time before tCKCKEH. CK must meet tCKCKEH before CKE is driven high. When CKE is driven high the clock frequency must be returned to the original frequency (the frequency corresponding to the FSP at which Command Bus Training mode was entered)
2. CS and CA[5:0] must be Deselect (all low) tCKCKEH before CKE is driven high.
3. When CKE is driven high, the SDRAM's ODT\_CA will revert to the state/value defined by FSP-OP prior to Command Bus Training mode entry, i.e. the original frequency set point (FSP-OP, MR13-OP[7]).  
Example: If the SDRAM was using FSP-OP[1] for training, then it will switch to FSP-OP[0] when CKE is driven HIGH.
4. Training values are not retained by the SDRAM, and must be written to the FSP-OP register set before returning to operation at the trained frequency.  
Example: VREF(ca) will return to the value programmed in the original set point.
5. When CKE is driven high the LPDDR4-SDRAM will revert to the FSP in operation when Command Bus Training mode was entered.

### 3.24. Frequency Set Point (FSP)

Frequency Set-Points allow the LPDDR4-SDRAM CA Bus to be switched between two differing operating frequencies, with changes in voltage swings and termination values, without ever being in an un-trained state which could result in a loss of communication to the DRAM. This is accomplished by duplicating all CA Bus mode register parameters, as well as other mode register parameters commonly changed with operating frequency. These duplicated registers form two sets that use the same mode register addresses, with read/write access controlled by MR bit FSP-WR (Frequency Set-Point Write/Read) and the DRAM operating point controlled by another MR bit FSP-OP (Frequency Set-Point Operation). Changing the FSP-WR bit allows MR parameters to be changed for an alternate Frequency Set-Point without affecting

the LPDDR4-SDRAM's current operation. Once all necessary parameters have been written to the alternate Set-Point, changing the FSP-OP bit will switch operation to use all of the new parameters simultaneously (within tFC), eliminating the possibility of a loss of communication that could be caused by a partial configuration change.

Parameters which have two physical registers controlled by FSP-WR and FSP-OP include:

**Table - Mode Register Function with two physical registers**

MR#	Operand	Function	Note
MR1	OP[3]	RD-PRE (RD Pre-amble Type)	
	OP[6:4]	nWR (Write-Recovery for Auto-Pre-charge commands)	
	OP[7]	RPST (RD Post-Ambles Length)	
MR2	OP[2:0]	RL (Read Latency)	
	OP[5:3]	WL (Write Latency)	
	OP[6]	WLS (Write Latency Set)	
MR3	OP[0]	PU-Cal (Pull-up Calibration Point)	1
	OP[1]	WR PST (WR Post-Ambles Length)	
	OP[5:3]	PDDS (Pull-down Drive Strength)	
	OP[6]	DBI-RD (DBI Read Enable)	
	OP[7]	DBI-WR (DBI Write Enable)	
MR11	OP[2:0]	DQ ODT (DQ Bus Receiver On-Die-Termination)	
	OP[6:4]	CA ODT (CA Bus Receiver On-Die-Termination)	
MR12	OP[5:0]	VREF(ca) (Vref(ca) Setting)	
	OP[6]	VR-CA (Vref(ca) Range)	
MR14	OP[5:0]	Vref(dq) (Vref(dq) Setting)	
	OP[6]	VR-DQ (Vref(dq) Range)	
MR22	OP[2:0]	SoC ODT (Controller ODT Value for VOH calibration)	
	OP[3]	ODTE-CK (CK ODT Enabled for nonterminating rank)	
	OP[4]	ODTE-CS (CS ODT enable for non terminating rank)	
	OP[5]	ODTD-CA (CA ODT termination disable)	

Note:

1. The synchronization MR3 OP[0] setting between Ch.0 and Ch.1 then the ZQ calibration is required in order to achieve a Driver strength and ODT tolerance to change MR3 OP[0] PU-CAL is changed through FSP.

See Mode Register Definition for more details.

Following table shows how the two mode registers for each of the parameters above can be modified by setting the appropriate FSP-WR value, and how device operation can be switched between operating points by setting the appropriate FSP-OP value. The FSP-WR and FSP-OP functions operate completely independently.

Function	MR# & Operand	Data	Operation	Note
FSP-WR	MR13 OP[6]	0 (Default)	Data write to Mode Register N for FSP-OP[0] by MRW command.	1
		1	Data write to Mode Register N for FSP-OP[1] by MRW command.	
FSP-OP	MR13 OP[7]	0 (Default)	DRAM operates with Mode Register N for FSP-OP[0] setting.	2
		1	DRAM operates with Mode Register N for FSP-OP[1] setting.	

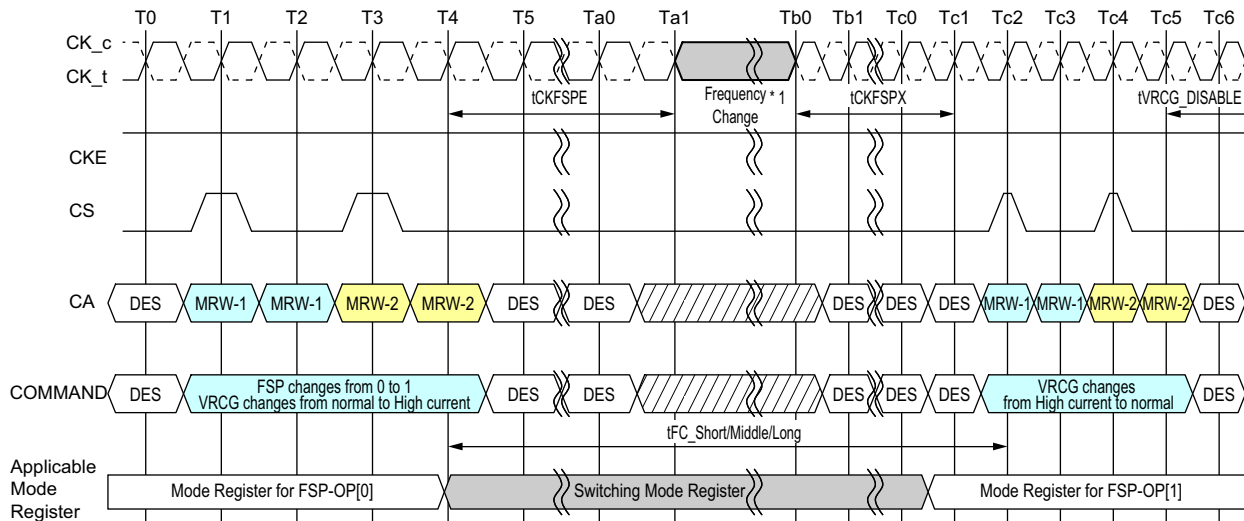
Notes:



1. FSP-WR stands for Frequency Set Point Write/Read.
2. FSP-OP stands for Frequency Set Point Operating Point.

### 3.24.0.1. Frequency Set Point update timing

The Frequency set point update timing is shown in the timing diagram below. When changing the frequency set point via MR13 OP[7], the VRCG setting: MR13 OP[3] have to be changed into VREF Fast Response (high current) mode at the same time. After Frequency change time( $t_{FC}$ ) is satisfied. VRCG can be changed into Normal Operation mode via MR13 OP[3].

**Figure - Frequency Set Point Switching Timing**



NOTES : 1. The definition that is Clock frequency change during CKE HIGH should be followed at the frequency change operation. For more information, refer to Section 4.42 Input Clock Stop and Frequency Change. 
 DONT CARE  TIME BREAK

**Note.**

1. The definition that is Clock frequency change during CKE HIGH should be followed at the frequency change operation. For more information, refer to 3.40. Input clock stop and frequency change.



**Table - tFC value mapping**

Application	Step size		Range	
	From FSP-OP0	To FSP-OP1	From FSP-OP0	To FSP-OP1
tFC_Short	Base	A single step increment/decrement	Base	No Change
tFC_Middle	Base	Two or more steps increment/decrement	Base	No Change
tFC_Long	-	-	Base	Change

Notes:

1. As well as from FSP-OP1 to FSP-OP0

**Table - tFC value mapping example**

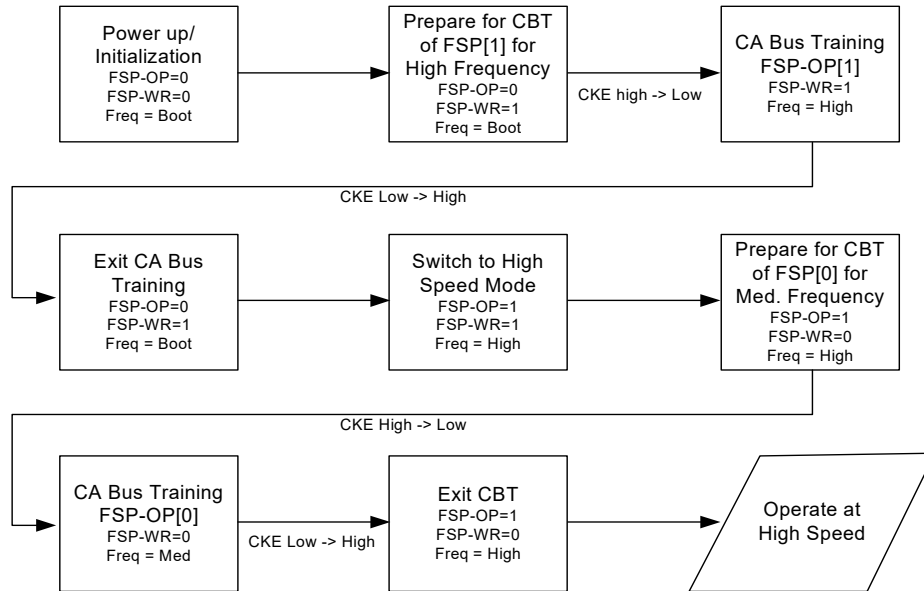
Case	From/To	FSP-OP MR13 OP[7]	Vref(ca) set- ting: MR12: OP[5:0]	Vref(ca) Range: MR12 OP[6]	Application	Note
1	From	0	001100	0	tFC_Short	1
	To	1	001101	0		
2	From	0	001100	0	tFC_Middle	2
	To	1	001110	0		
3	From	0	Don't care	0	tFC_Long	3
	To	1	Don't care	1		

Notes:

1. A single step size increment/decrement for Vref(ca) Setting Value.
2. Two or more step size increment/decrement for Vref(ca) Setting Value.
3. VREF(ca) Range is changed. In tis case changing VREF(ca) Setting doesn't affect tFC value.

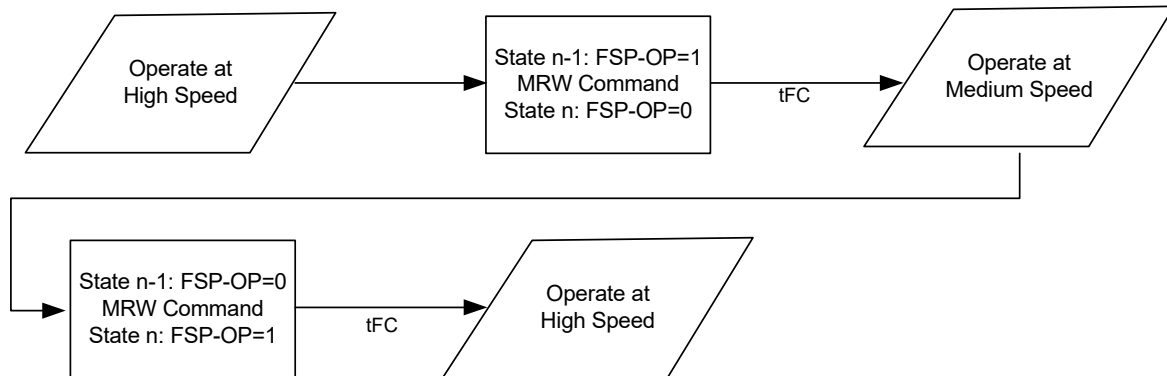
The LPDDR4-SDRAM defaults to FSP-OP[0] at power-up. Both Set-Points default to settings needed to operate in un-terminated, low-frequency environments. To enable the LPDDR4-SDRAM to operate at higher frequencies, Command Bus Training mode should be utilized to train the alternate Frequency Set-Point (Figure "Training Two Frequency Set Points"). See the section Command Bus Training for more details on this training mode.

**Figure - Training Two Frequency Set Points**



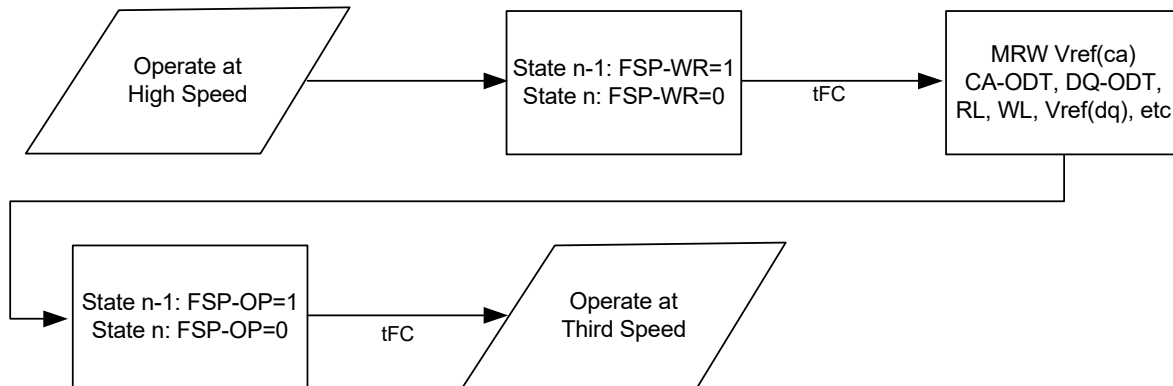
Once both Frequency Set Points have been trained, switching between points can be performed by a single MRW followed by waiting for tFC (figure below)

**Figure - Switching between two trained Frequency Set Points**



Switching to a third (or more) Set-Point can be accomplished if the memory controller has stored the previously-trained values (in particular the Vref-CA calibration value) and re-writes these to the alternate Set-Point before switching FSP-OP (Figure below).

**Figure - Switching to a third trained Frequency Set Point**



### 3.25. Write Leveling Mode

To improve signal-integrity performance, the LPDDR4 SDRAM provides a write-leveling feature to compensate CK-to-DQS timing skew affecting timing parameters such as  $t_{DQSS}$ ,  $t_{DSS}$ , and  $t_{DSH}$ . The DRAM samples the clock state with the rising edge of DQS signals, and asynchronously feeds back to the memory controller. The memory controller references this feedback to adjust the clock-to-data strobe signal relationship for each DQS<sub>t</sub>/DQS<sub>c</sub> signal pair.

All data bits (DQ[7:0] for DQS<sub>t</sub>/DQS<sub>c</sub>[0], and DQ[15:8] for DQS<sub>t</sub>/DQS<sub>c</sub>[1]) carry the training feedback to the controller. Both DQS signals in each channel must be leveled independently. Write-leveling entry/exit is independent between channels.

The LPDDR4 SDRAM enters into write-leveling mode when mode register MR2-OP[7] is set HIGH. When entering write-leveling mode, the state of the DQ pins is undefined. During write-leveling mode, only DESELECT commands are allowed, or a MRW command to exit the write-leveling operation. Depending on the absolute values of  $t_{QSL}$  and  $t_{QSH}$  in the application, the value of  $t_{DQSS}$  may have to be better than the limits provided in the chapter "AC Timing Parameters" in order to satisfy the  $t_{DSS}$  and  $t_{DSH}$  specification. Upon completion of the write-leveling operation, the DRAM exits from write-leveling mode when MR2-OP[7] is reset LOW.

Write Leveling should be performed before Write Training (DQS2DQ Training).

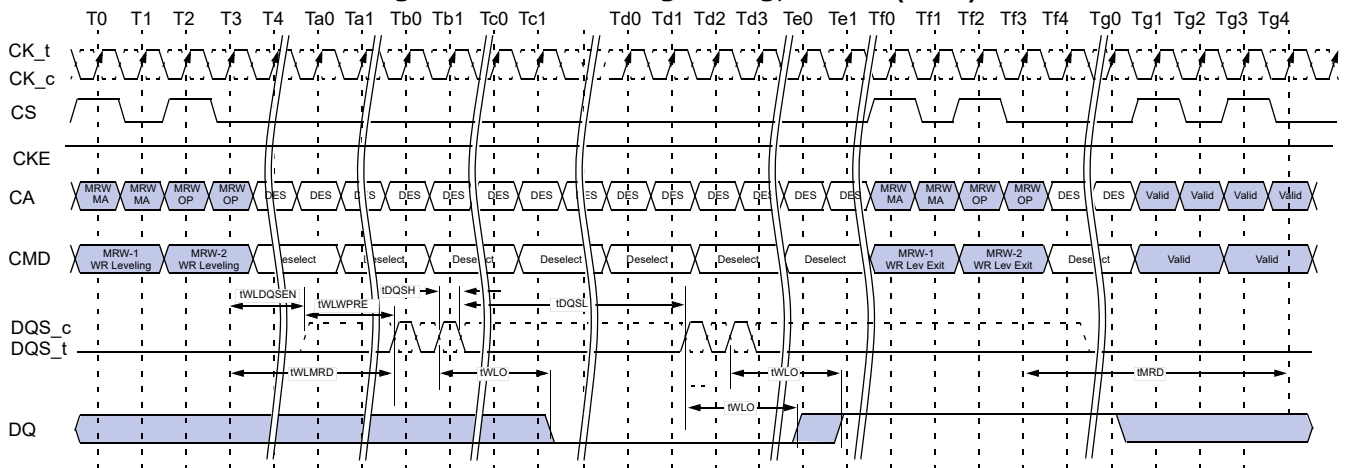
#### Write Leveling Procedure:

1. Enter into Write-leveling mode by setting MR2-OP[7]=1,
2. Once entered into Write-leveling mode, DQS<sub>t</sub> must be driven LOW and DQS<sub>c</sub> HIGH after a delay of  $t_{WLDQSEN}$ .
3. Wait for a time  $t_{WLMRD}$  before providing the first DQS signal input. The delay time  $t_{WLMRD}(MAX)$  is controller-dependent.
4. DRAM may or may not capture first rising edge of DQS<sub>t</sub> due to an unstable first risign edge. Hence provide at least consecutive 2 pulses of DQS signal input is required in every DQS input signal during Write Training Mode. The captured clock level by each DQS edges are overwritten at any time and the DRAM provides asynchronous feedback on all the DQ bits after time  $t_{WLO}$ .

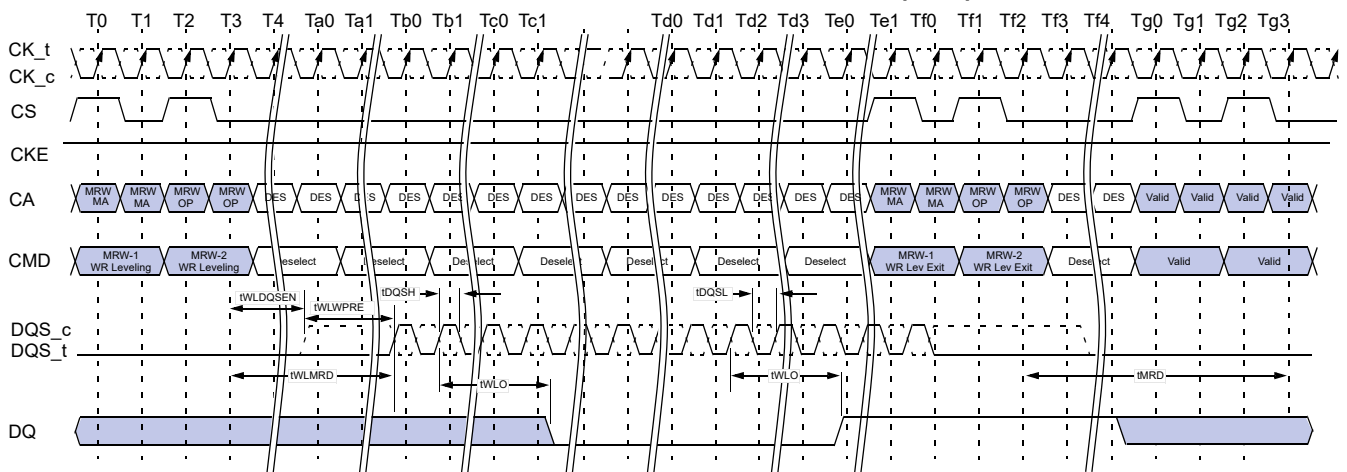
5. The feedback provided by the DRAM is referenced by the controller to increment or decrement the DQS\_t and/or DQS\_c delay settings.
6. Repeat step 4 through step 5 until the proper DQS\_t/DQS\_c delay is established.
7. Exit from Write-leveling mode by setting MR2-OP[7]=0.

A Write Leveling timing example is shown in figure below.

**Figure - Write Leveling Timing, tDQSL(max)**



**Figure - Write Leveling Timing, tDQSL(min)**

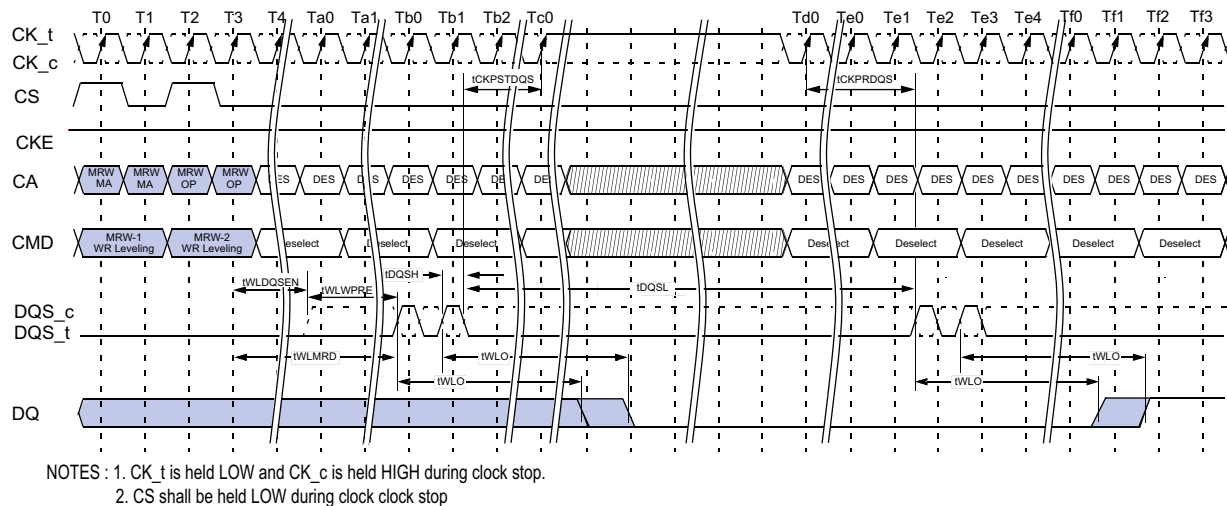


### 3.25.1. Input Clock Frequency Stop and Change

The input clock frequency can be stopped or changed from one stable clock rate to another stable clock rate during Write Leveling mode.

The Frequency stop or change timing is shown in Figure below

**Figure - Clock Stop and Timing during Write Leveling**



### 3.26. MPC [RD DQ Calibration] Command

LPDDR4 devices feature a RD DQ Calibration training function that outputs a 16-bit user-defined pattern on the DQ pins. RD DQ Calibration is initiated by issuing a MPC [RD DQ Calibration] command followed by a CAS-2 command, cause the LPDDR4-SDRAM to drive the contents of MR32 followed by the contents of MR40 on each of DQ[15:0] and DMI[1:0]. The pattern can be inverted on selected DQ pins according to user-defined invert masks written to MR15 and MR20.

#### RD DQ Calibration Training Procedure

The procedure for executing RD DQ Calibration is:

- Issue MRW commands to write MR32 (first eight bits), MR40 (second eight bits), MR15 (eight-bit invert mask for byte 0), and MR20 (eight-bit invert mask for byte 1)
  - o Optionally this step could be skipped to use the default patterns
    - MR32 default = 5Ah
    - MR40 default = 3Ch
    - MR15 default = 55h
    - MR20 default = 55h
- Issue an MPC [RD DQ Calibration] command followed immediately by a CAS-2 command
  - o Each time an MPC [RD DQ Calibration] command followed by a CAS-2 is received by the LPDDR4 SDRAM, a 16-bit data burst will, after the currently set RL, drive the eight bits programmed in MR32 followed by the eight bits programmed in MR40 on all I/O pins
  - o The data pattern will be inverted for I/O pins with a '1' programmed in the corresponding invert mask mode register bit (see Table - Invert Mask Assignments)
  - o Note that the pattern is driven on the DMI pins, but no data bus inversion function is enabled,

even if Read DBI is enabled in the DRAM mode register.

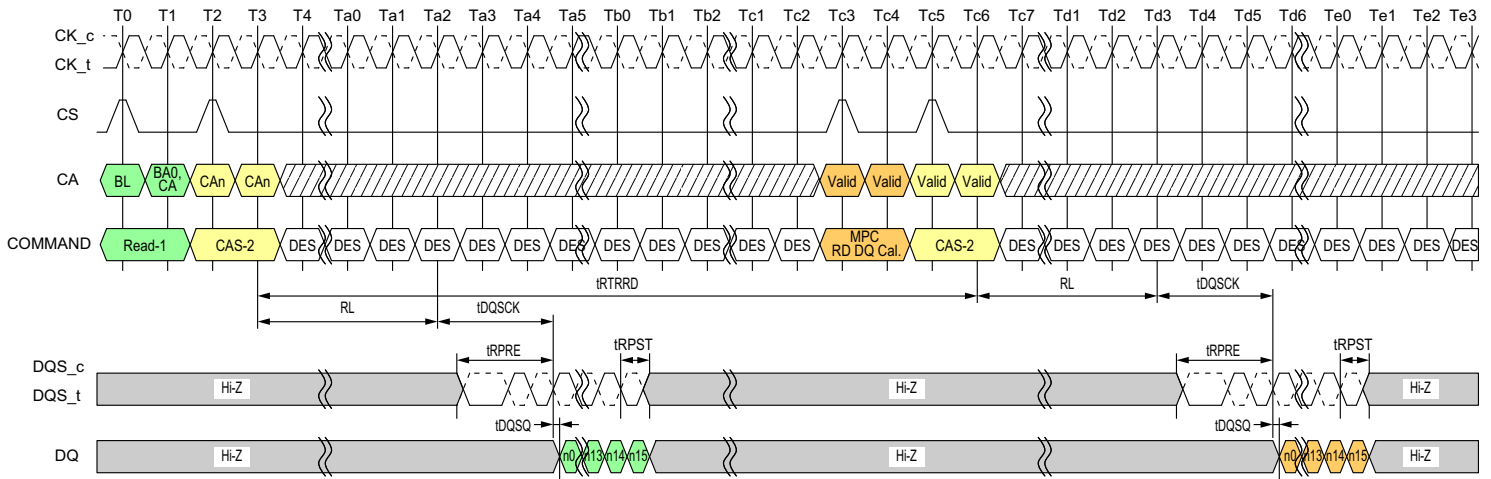
- o The MPC-1 [RD DQ Calibration] command can be issued every tCCD seamlessly, and tRTRRD delay is required between Array Read command and the MPC-1 [RD DQ Calibration] command as well the delay required between the MPC-1 [RD DQ Calibration] command and an array read.
- o The operands received with the CAS-2 command must be driven LOW

- DQ Read Training can be performed with any or no banks active, during Refresh, or during SREF with CKE high

**Table - Invert Mask Assignments**

Pin	DQ8	DQ9	DQ10	DQ11	DMI1	DQ12	DQ13	DQ14	DQ15
MR20	OP0	OP1	OP2	OP3	N/A	OP4	OP5	OP6	OP7
Pin	DQ0	DQ1	DQ2	DQ3	DMI0	DQ4	DQ5	DQ6	DQ7
MR15	OP0	OP1	OP2	OP3	N/A	OP4	OP5	OP6	OP7

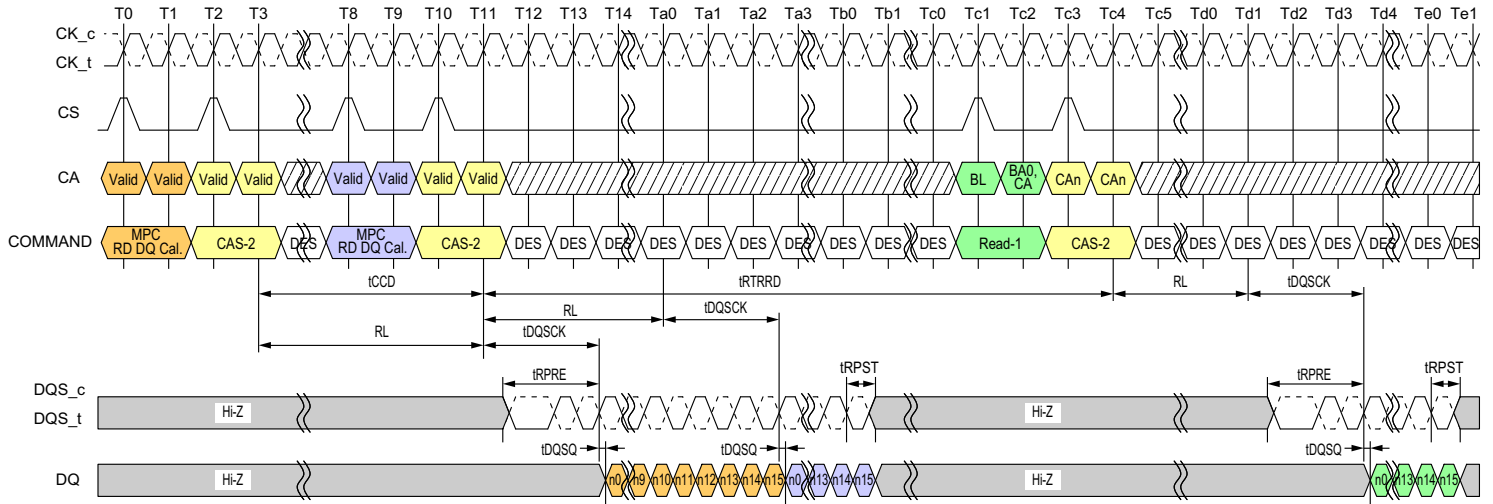
**Figure - DQ Read Training Timing: Read to Read DQ Calibration**



- NOTES :
1. Read-1 to MPC [RD DQ Calibration] Operation is shown as an example of command-to-command timing. Timing from Read-1 to MPC [RD DQ Calibration] command is tRTRRD.
  2. MPC [RD DQ Calibration] uses the same command-to-data timing relationship (RL, tDQSCCK, tDQSQ) as a Read-1 command.
  3. BL = 16, Read Preamble: Toggle, Read Postamble: 0.5nCK.
  4. DES commands are shown for ease of illustration; other commands may be valid at these times.

▨ DONT CARE    >>> TIME BREAK

**Figure - DQ Read Training Timing: Read DQ Cal. to Read DQ Cal. / Read**



- NOTES :
1. MPC [RD DQ Calibration] to MPC [RD DQ Calibration] Operation is shown as an example of command-to-command timing.
  2. MPC [RD DQ Calibration] to Read-1 Operation is shown as an example of command-to-command timing.
  3. MPC [RD DQ Calibration] uses the same command-to-data timing relationship (RL, tDQSQ, tDQSQ) as a Read-1 command.
  4. Seamless MPC [RD DQ Calibration] commands may be executed by repeating the command every tCCD time.
  5. Timing from MPC [RD DQ Calibration] command to Read-1 is tRTRRD.
  6. BL = 16, Read Preamble: Toggle, Read Postamble: 0.5nCK.
  7. DES commands are shown for ease of illustration; other commands may be valid at these times.

DONT CARE    
 TIME BREAK



### 3.26.1. MPC [RD DQ Calibration] Example

An example of MPC [RD DQ Calibration] output is shown in Table - MPC [RD DQ Calibration] Bit Ordering and Inversion Example. This shows the 16-bit data pattern that will be driven on each DQ when one DQ Read Training command is executed. This output assumes the following mode register values are used:

- MR32 = 1CH
- MR40 = 59H
- MR15 = 55H
- MR20 = 55H

**Table - MPC [RD DQ Calibration] Bit Ordering and Inversion Example**

Pin	Invert?	Bit sequence ->															
		15	14	13	12	11	10	9	8	7	6	5	4	3	2	1	0
DQ0	Yes	1	0	1	0	0	1	1	0	1	1	1	0	0	0	1	1
DQ1	No	0	1	0	1	1	0	0	1	0	0	0	1	1	1	0	0
DQ2	Yes	1	0	1	0	0	1	1	0	1	1	1	0	0	0	1	1
DQ3	No	0	1	0	1	1	0	0	1	0	0	0	1	1	1	0	0
DMI0	Never	0	1	0	1	1	0	0	1	0	0	0	1	1	1	0	0
DQ4	Yes	1	0	1	0	0	1	1	0	1	1	1	0	0	0	1	1
DQ5	No	0	1	0	1	1	0	0	1	0	0	0	1	1	1	0	0
DQ6	Yes	1	0	1	0	0	1	1	0	1	1	1	0	0	0	1	1
DQ7	No	0	1	0	1	1	0	0	1	0	0	0	1	1	1	0	0
DQ8	Yes	1	0	1	0	0	1	1	0	1	1	1	0	0	0	1	1
DQ9	No	0	1	0	1	1	0	0	1	0	0	0	1	1	1	0	0
DQ10	Yes	1	0	1	0	0	1	1	0	1	1	1	0	0	0	1	1
DQ11	No	0	1	0	1	1	0	0	1	0	0	0	1	1	1	0	0
DMI1	Never	0	1	0	1	1	0	0	1	0	0	0	1	1	1	0	0
DQ12	Yes	1	0	1	0	0	1	1	0	1	1	1	0	0	0	1	1
DQ13	No	0	1	0	1	1	0	0	1	0	0	0	1	1	1	0	0
DQ14	Yes	1	0	1	0	0	1	1	0	1	1	1	0	0	0	1	1
DQ15	No	0	1	0	1	1	0	0	1	0	0	0	1	1	1	0	0

Notes:

1. The patterns contained in MR32 and MR40 are transmitted on DQ[15:0] and DMI[1:0] when RD DQ Calibration is initiated via a MPC [RD DQ Calibration] command. The pattern transmitted serially on each data lane, organized "little endian" such that the low order bit in a byte is transmitted first. If the data pattern is 27H, then the first bit transmitted will be a '1', followed by '1', '1', '0', '0', '1', '0', and '0'. The bit stream will be 00100111.
2. MR15 and MR22 may be used to invert the MR32/MR40 data pattern on the DQ pins. See MR15 and MR20 for more information. Data is never inverted on the DMI[1:0] pins.
3. DMI [1:0] outputs status follows in the table below

**Table - MR Setting vs. DMI Status**

DM Function MR13 OP[5]	Write DBI <sub>dc</sub> Function MR3 OP[7]	Read DBI <sub>dc</sub> Function MR3 OP[6]	DMI Status
1: Disable	0: Disable	0: Disable	Hi-Z
1: Disable	1: Enable	0: Disable	The data pattern is transmitted
1: Disable	0: Disable	1: Enable	The data pattern is transmitted
1: Disable	1: Enable	1: Enable	The data pattern is transmitted
0: Enable	0: Disable	0: Disable	The data pattern is transmitted

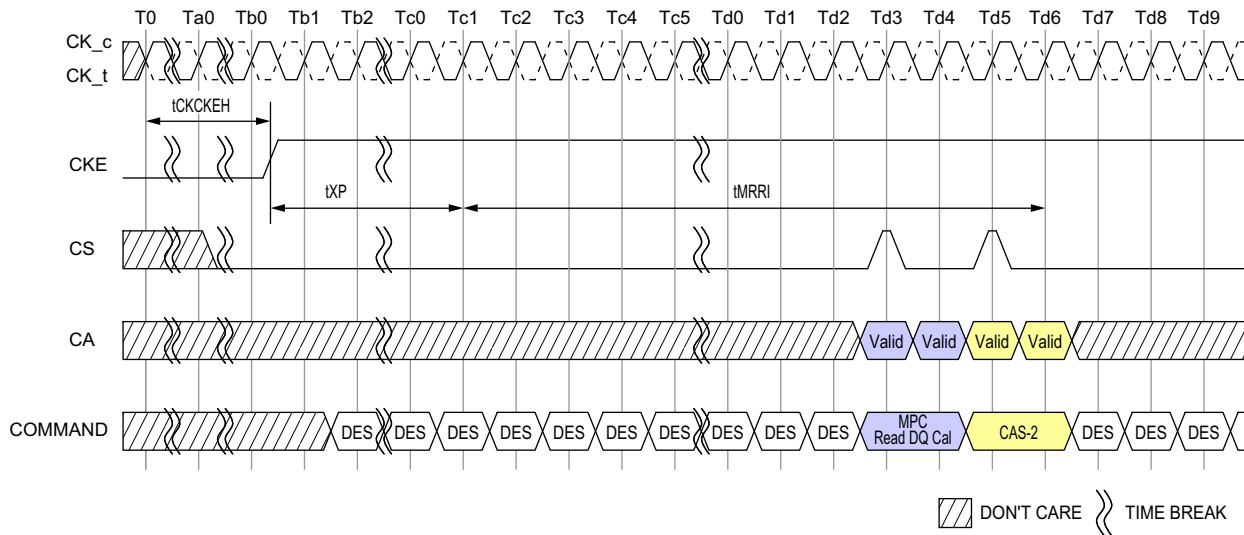
DM Function MR13 OP[5]	Write DBI <sub>dc</sub> Function MR3 OP[7]	Read DBI <sub>dc</sub> Function MR3 OP[6]	DMI Status
0: Enable	1: Enable	0: Disable	The data pattern is transmitted
0: Enable	0: Disable	1: Enable	The data pattern is transmitted
0: Enable	1: Enable	1: Enable	The data pattern is transmitted

4. No Data Bus Inversion (DBI) function is enacted during RD DQ Calibration, even if DBI is enabled in MR3-OP[6].

### 3.26.2. MPC of Read DQ Calibration after Power-Down Exit

Following the power-down state, an additional time,  $t_{MRRI}$ , is required prior to issuing the MPC of Read DQ Calibration command. This additional time (equivalent to  $t_{RCD}$ ) is required in order to be able to maximize power-down current savings by allowing more power-up time for the Read DQ data in MR32 and MR40 data path after exit from standby, power-down mode.

**Figure - MPC Read DQ Calibration Following Power-Down State**



### 3.27. MPC Write Training (DQS-DQ Training)

The LPDDR4-SDRAM uses an un-matched DQS-DQ path to enable high speed performance and save power in the DRAM. As a result, the DQS strobe must be trained to arrive at the DQ latch center-aligned with the Data eye. The SDRAM DQ receiver is located at the DQ pad, and has a shorter internal delay in the SDRAM than does the DQS signal. The SDRAM DQ receiver will latch the data present on the DQ bus when DQS reaches the latch, and training is accomplished by delaying the DQ signals relative to DQS such that the Data eye arrives at the receiver latch centered on the DQS transition.

Two modes of training are available in LPDDR4:

- Command-based FIFO WR/RD with user patterns
- A internal DQS clock-tree oscillator, to determine the need for, and the magnitude of, required training.

The command-based FIFO WR/RD uses the MPC command with operands to enable this special mode of operation. When issuing the MPC command, if OP6 is set LOW then the DRAM will perform a NOP command. When OP6 is set HIGH, then OP5:0 enable training functions or are reserved for future use (RFU). MPC commands that initiate a Read FIFO, READ DQ Calibration or Write FIFO to the SDRAM must be followed immediately by a CAS-2 command. See "Multi Purpose Command (MPC) Definition" for more information.

To perform Write Training, the controller can issue a MPC [Write DQ FIFO] command with OP[6:0] set as described in the MPC Definition section, followed immediately by a CAS-2 command (CAS-2 operands should be driven LOW) to initiate a Write DQ FIFO. Timings for MPC [Write DQ FIFO] are identical to a Write command, with WL (Write Latency) timed from the 2nd rising clock edge of the CAS-2 command. Up to 5 consecutive MPC [Write DQ FIFO] commands with user defined patterns may be issued to the SDRAM to store up to 80 values (BL16 x5) per pin that can be read back via the MPC [Read DQ FIFO] command. Write/Read FIFO Pointer operation is described later in this section.

After writing data to the SDRAM with the MPC [Write DQ FIFO] command, the data can be read back with the MPC [Read DQ FIFO] command and results compared with "expect" data to see if further training (DQ delay) is needed. MPC [Read DQ FIFO] is initiated by issuing a MPC command with OP[6:0] set as described in the MPC Definition section, followed immediately by a CAS-2 command (CAS-2 operands must be driven LOW). Timings for the MPC [Read DQ FIFO] command are identical to a Read command, with RL (Read Latency) timed from the 2nd rising clock edge of the CAS-2 command.

Read DQ FIFO is non-destructive to the data captured in the FIFO, so data may be read continuously until it is either overwritten by a Write DQ FIFO command or disturbed by CKE LOW or any of the following commands; Write, Masked Write, Read, Read DQ Calibration and a MRR. If fewer than 5 Write DQ FIFO commands were executed, then unwritten registers will have un-defined (but valid) data when read back.

The following command about MRW is only allowed from MPC [Write DQ FIFO] command to MPC [Read DQ FIFO]. Allowing MRW command is for OP[7]:FSP-OP, OP[6]:FSP-WR and OP[3]:VRCG of MR13 and MR14. And the rest of MRW command is prohibited.

For example: If 5 Write DQ FIFO commands are executed sequentially, then a series of Read DQ FIFO commands will read valid data from FIFO[0], FIFO[1]...FIFO[4], and will then wrap back to FIFO[0] on the next Read DQ FIFO.

On the other hand, if fewer than 5 Write DQ FIFO commands are executed sequentially (example=3), then a series of Read DQ FIFO commands will return valid data for FIFO[0], FIFO[1], and FIFO[2], but the next two Read DQ FIFO commands will return un-defined data for FIFO[3] and FIFO[4] before wrapping back to the valid data in FIFO[0].

### 3.27.1. FIFO Pointer Reset and Synchronism

The Write DQ FIFO pointer is reset under the following conditions:

- Power-up initialization
- RESET\_n asserted
- Power-down entry
- Self Refresh Power-Down entry

The MPC [Write DQ FIFO] command advances the WR-FIFO pointer, and the MPC [Read DQ FIFO] advances the RD-FIFO pointer. Also any normal (non-FIFO) Read Operation (RD, RDA) advances both WR-FIFO pointer and RD-FIFO pointer. Issuing (non-FIFO) Read Operation command is inhibited during Write training period. To keep the pointers aligned, the SoC memory controller must adhere to the following restriction at the end of Write training period:

$$b = a + (n * c)$$

Where:

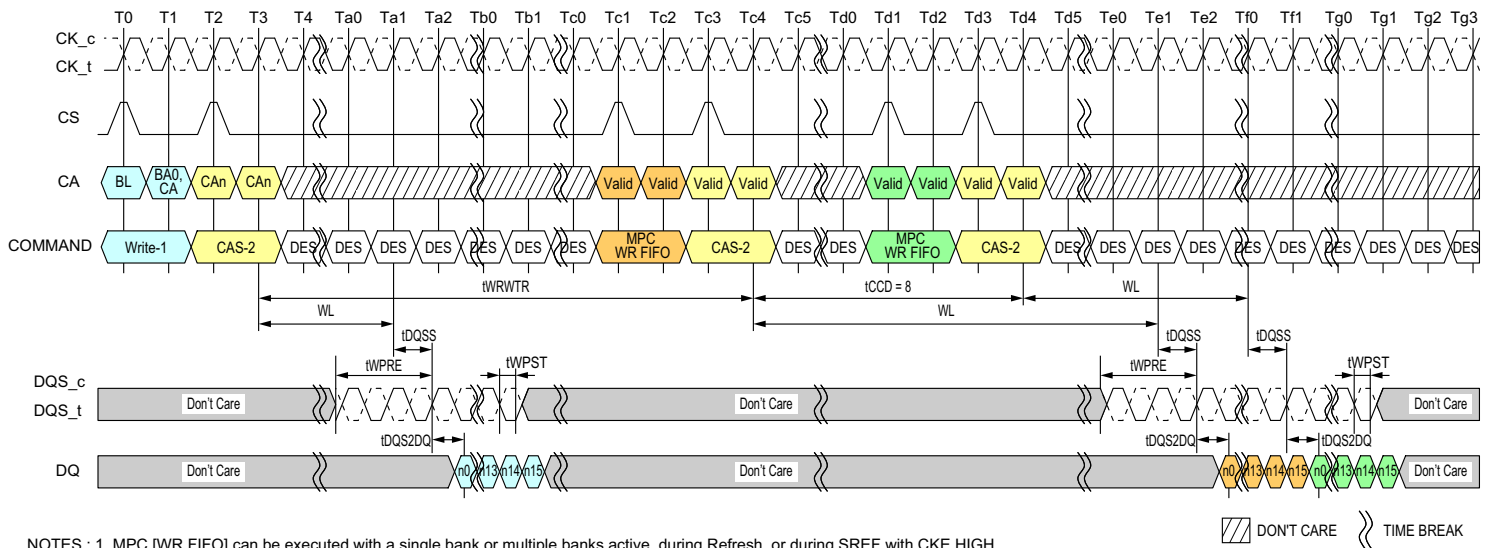
'a' is the number of MPC [Write DQ FIFO] commands

'b' is the number of MPC [Read DQ FIFO] commands

'c' is the FIFO depth (=5 for LPDDR4)

'n' is a positive integer,  $\geq 0$

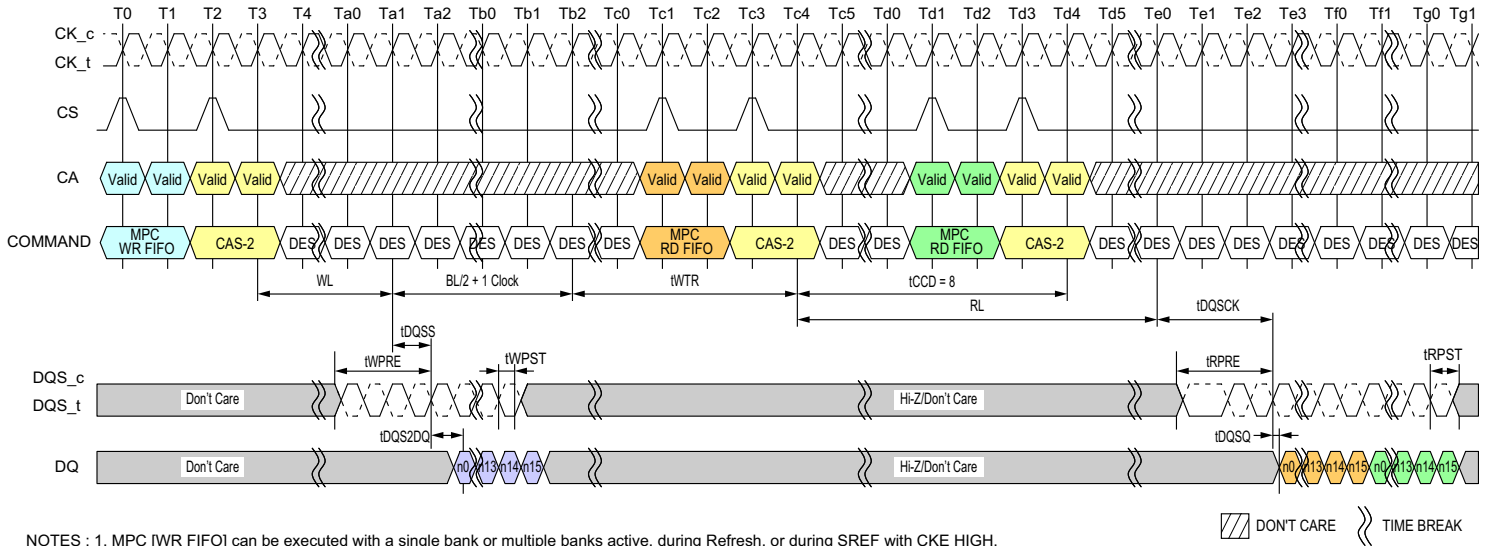
**Figure - MPC [Write DQ FIFO] Operation Timing**



- NOTES :
- MPC [WR FIFO] can be executed with a single bank or multiple banks active, during Refresh, or during SREF with CKE HIGH.
  - Write-1 to MPC is shown as an example of command-to-command timing for MPC. Timing from Write-1 to MPC [WR-FIFO] is  $tWRWTR$ .
  - Seamless MPC [WR-FIFO] commands may be executed by repeating the command every  $tCCD$  time.
  - MPC [WR-FIFO] uses the same command-to-data timing relationship ( $WL$ ,  $tDQSS$ ,  $tDQS2DQ$ ) as a Write-1 command.
  - A maximum of 5 MPC [WR-FIFO] commands may be executed consecutively without corrupting FIFO data.  
The 6th MPC [WR-FIFO] command will overwrite the FIFO data from the first command. If fewer than 5 MPC [WR-FIFO] commands are executed, then the remaining FIFO locations will contain undefined data.
  - For the CAS-2 command following a MPC command, the CAS-2 operands must be driven "LOW."
  - To avoid corrupting the FIFO contents, MPC [RD-FIFO] must immediately follow MPC [WR-FIFO]/CAS-2 without any other command disturbing FIFO pointers in-between. FIFO pointers are disturbed by CKE Low, Write, Masked Write, Read, Read DQ Calibration and MRR.
  - $BL = 16$ , Write Postamble =  $0.5nCK$
  - DES commands are shown for ease of illustration; other commands may be valid at these times.

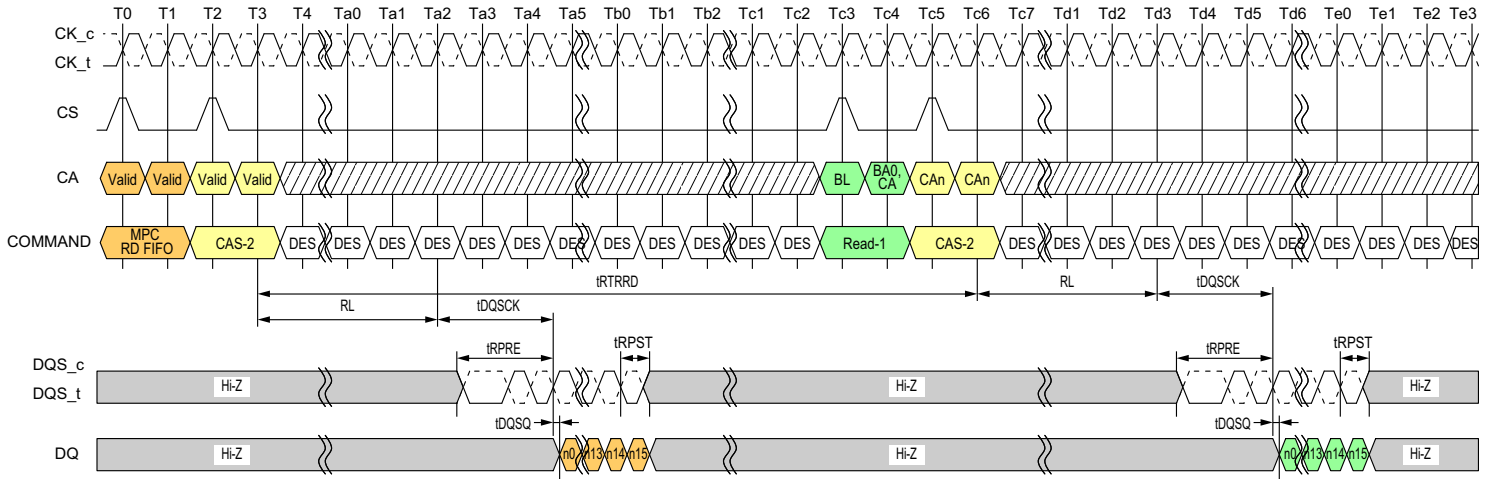
▨ DONT CARE    ⋈ TIME BREAK

**Figure - MPC [Write FIFO] to MPC [Read FIFO] Timing**



- NOTES:
- MPC [WR FIFO] can be executed with a single bank or multiple banks active, during Refresh, or during SREF with CKE HIGH.
  - MPC [WR-FIFO] to MPC [RD-FIFO] is shown as an example of command-to-command timing for MPC. Timing from MPC [WR-FIFO] to MPC [RD-FIFO] is specified in the command-to-command timing table.
  - Seamless MPC [RD-FIFO] commands may be executed by repeating the command every  $t_{CCD}$  time.
  - MPC [RD-FIFO] uses the same command-to-data timing relationship (RL,  $t_{DQSS}$ ,  $t_{DQS2DQ}$ ) as a Read-1 command.
  - Data may be continuously read from the FIFO without any data corruption. After 5 MPC [RD-FIFO] commands the FIFO pointer will wrap back to the 1st FIFO and continue advancing. If fewer than 5 MPC [WR-FIFO] commands were executed, then the MPC [RD-FIFO] commands to those FIFO locations will return undefined data. See the Write Training section for more information on the FIFO pointer behavior.
  - For the CAS-2 command immediately following a MPC command, the CAS-2 operands must be driven "LOW."
  - DM[1:0] signals will be driven if any of WR-DBI, RD-DBI, or DM is enabled in the mode registers. See Write Training section for more information on DMI behavior.
  - BL = 16, Write Postamble = 0.5nCK, Read Preamble: Toggle, Read Postamble: 0.5nCK
  - DES commands are shown for ease of illustration; other commands may be valid at these times.

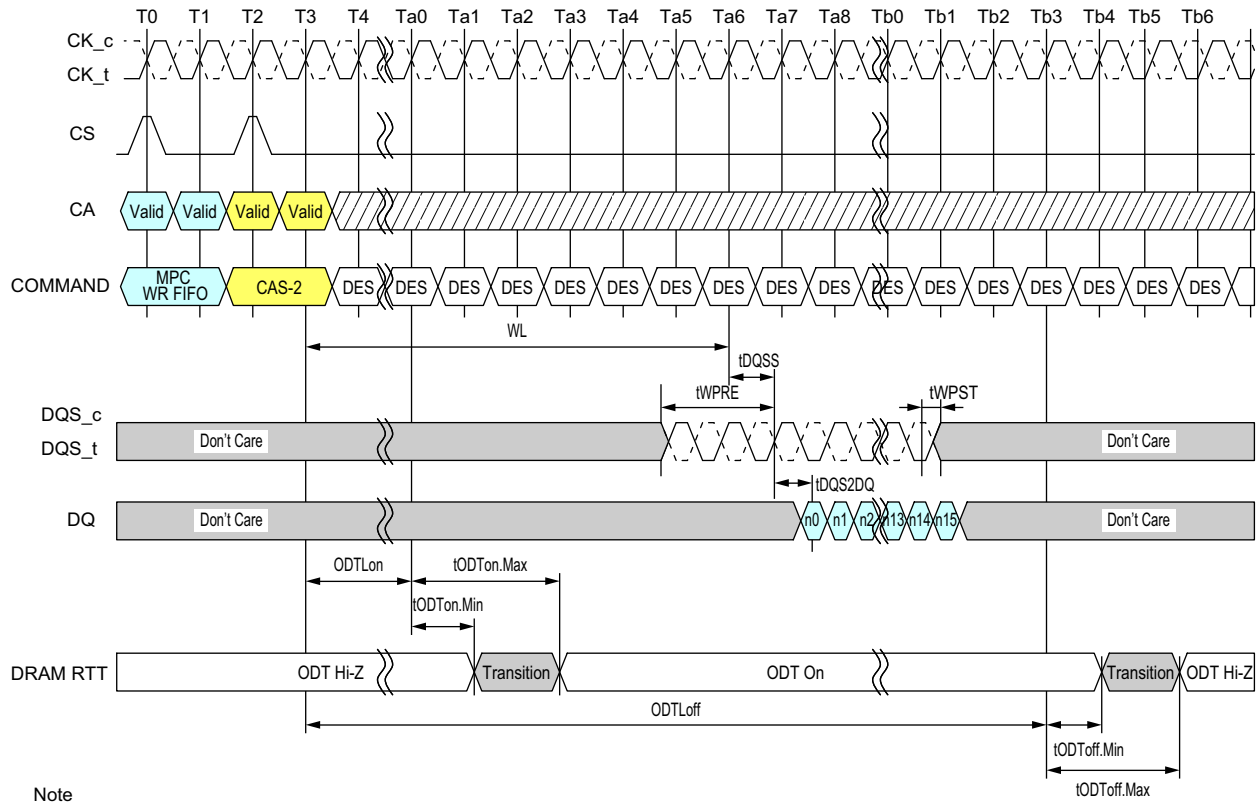
**Figure - MPC [Read FIFO] to Read Timing**



- NOTES:
- MPC [WR FIFO] can be executed with a single bank or multiple banks active, during Refresh, or during SREF with CKE HIGH.
  - MPC [RD-FIFO] to Read-1 Operation is shown as an example of command-to-command timing for MPC. Timing from MPC [RD-FIFO] command to Read is  $t_{RTRRD}$ .
  - Seamless MPC [RD-FIFO] commands may be executed by repeating the command every  $t_{CCD}$  time.
  - MPC [RD-FIFO] uses the same command-to-data timing relationship ( $RL$ ,  $t_{DQSCK}$ ,  $t_{DQSQ}$ ) as a Read-1 command.
  - Data may be continuously read from the FIFO without any data corruption. After 5 MPC [RD-FIFO] commands the FIFO pointer will wrap back to the 1st FIFO and continue advancing. If fewer than 5 MPC [WR-FIFO] commands were executed, then the MPC [RD-FIFO] commands to those FIFO locations will return undefined data. See the Write Training section for more information on the FIFO pointer behavior.
  - For the CAS-2 command immediately following a MPC command, the CAS-2 operands must be driven "LOW."
  - $DM[1:0]$  signals will be driven if any of WR-DBI, RD-DBI, or DM is enabled in the mode registers. See Write Training section for more information on DMI behavior.
  - $BL = 16$ , Read Preamble: Toggle, Read Postamble:  $0.5nCK$
  - DES commands are shown for ease of illustration; other commands may be valid at these times.

 DONT CARE  TIME BREAK

**Figure - MPC [Write FIFO] with DQ ODT Timing**

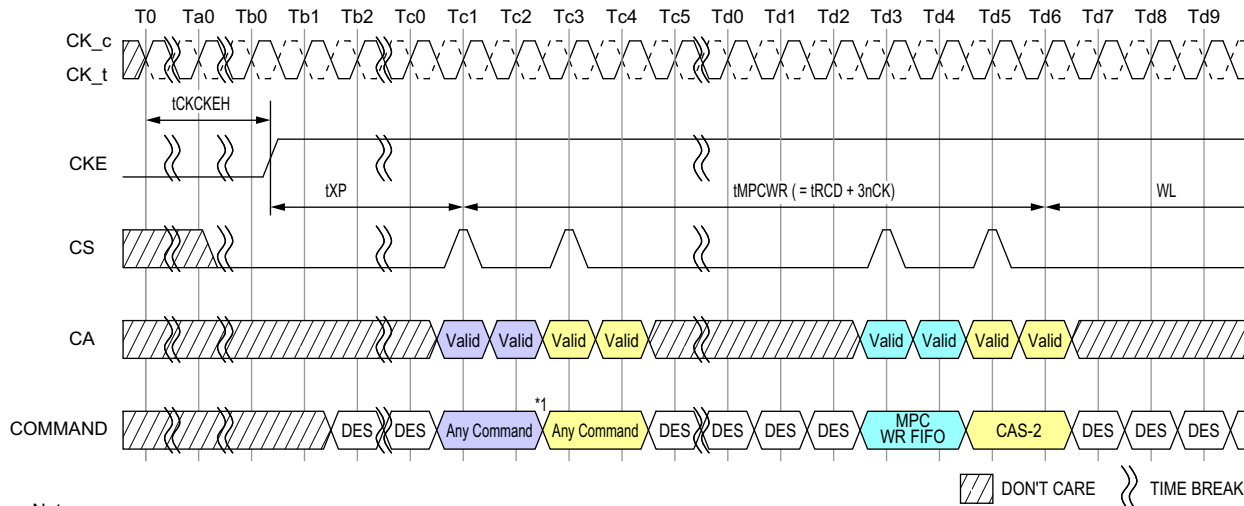


**Note**

1. MPC [WR FIFO] can be executed with a single bank or multiple banks active, during Refresh, or during SREF with CKE HIGH.
2. MPC [WR-FIFO] uses the same command-to-data/ODT timing relationship (WL, tDQSS, tDQS2DQ, ODTLon, ODTLoff, tODTOn, tODTOff) as a Write-1 command.
3. For the CAS-2 command immediately following a MPC command, the CAS-2 operands must be driven "LOW."
4. BL = 16, Write Postamble = 0.5nCK
5. DES commands are shown for ease of illustration; other commands may be valid at these times.

 DON'T CARE  TIME BREAK

**Figure - Power Down Exit to MPC [Write FIFO] Timing**



**Note**

1. Any commands except MPC WR FIFO and other exception commands defined other section in this document (i.e. MPC Read DQ Cal).
2. DES commands are shown for ease of illustration; other commands may be valid at these times.

### 3.28. DQS Interval Oscillator

As voltage and temperature change on the SDRAM die, the DQS clock tree delay will shift and may require re-training. The LPDDR4-SDRAM includes an internal DQS clock-tree oscillator to measure the amount of delay over a given time interval (determined by the controller), allowing the controller to compare the trained delay value to the delay value seen at a later time. The DQS Oscillator will provide the controller with important information regarding the need to re-train, and the magnitude of potential error.

The DQS Interval Oscillator is started by issuing a MPC [Start DQS Osc] command with OP[6:0] set as described in the MPC Operation section, which will start an internal ring oscillator that counts the number of time a signal propagates through a copy of the DQS clock tree.

The DQS Oscillator may be stopped by issuing a MPC [Stop DQS Osc] command with OP[6:0] set as described in the MPC Operation section, or the controller may instruct the SDRAM to count for a specific number of clocks and then stop automatically (See MR23 for more information). If MR23 is set to automatically stop the DQS Oscillator, then the MPC [Stop DQS Osc] command should not be used (illegal). When the DQS Oscillator is stopped by either method, the result of the oscillator counter is automatically stored in MR18 and MR19.

The controller may adjust the accuracy of the result by running the DQS Interval Oscillator for shorter (less accurate) or longer (more accurate) duration. The accuracy of the result for a given temperature and voltage is determined by the following equation:

$$\text{DQS Oscillator Granularity Error} = 2 * (\text{DQS delay}) / \text{run time}$$

Where:

- Run Time = total time between start and stop commands
- DQS delay = the value of the DQS clock tree delay ( $t_{DQS2DQ}$  min/max)



Additional matching error must be included, which is the difference between DQS training circuit and the actual DQS clock tree across voltage and temperature. The matching error is vendor specific.

Therefore, the total accuracy of the DQS Oscillator counter is given by:

$$\text{DQS Oscillator Accuracy} = 1 - \text{Granularity Error} - \text{Matching Error}$$

**For example:** If the total time between start and stop commands is 100ns, and the maximum DQS clock tree delay is 800ps (tDQS2DQ max), then the DQS Oscillator Granularity Error is:

$$\text{DQS Oscillator Granularity Error} = 2 * (0.8\text{ns}) / 100\text{ns} = 1.6\%$$

This equates to a granularity timing error or 12.8ps.

Assuming a circuit Matching Error of 5.5ps across voltage and temperature, then the accuracy is:

$$\text{DQS Oscillator Accuracy} = 1 - [(12.8 + 5.5) / 800] = 97.7\%$$

**For example:** running the DQS oscillator for a longer period improves the accuracy. If the total time between start and stop commands is 500ns, and the maximum DQS clock tree delay is 800ps (tDQS2DQ max), then the DQS Oscillator Granularity Error is:

$$\text{DQS Oscillator Granularity Error} = 2 * (0.8\text{ns}) / 500\text{ns} = 0.32\%$$

This equates to a granularity timing error or 2.56ps.

Assuming a circuit Matching Error of 5.5ps across voltage and temperature, then the accuracy is:

$$\text{DQS Oscillator Accuracy} = 1 - [(2.56 + 5.5) / 800] = 99.0\%$$

The result of the DQS Interval Oscillator is defined as the number of DQS Clock Tree Delays that can be counted within the "run time," determined by the controller. The result is stored in MR18-OP[7:0] and MR19-OP[7:0]. MR18 contains the least significant bits (LSB) of the result, and MR19 contains the most significant bits (MSB) of the result. MR18 and MR19 are overwritten by the SDRAM when a MPC-1 [Stop DQS Osc] command is received. The SDRAM counter will count to its maximum value (=2<sup>16</sup>) and stop. If the maximum value is read from the mode registers, then the memory controller must assume that the counter overflowed the register and discard the result. The longest "run time" for the oscillator that will not overflow the counter registers can be calculated as follows:

$$\text{Longest Run Time Interval} = 2^{16} * \text{tDQS2DQ}(\text{min}) = 2^{16} * 0.2\text{ns} = 13.1\mu\text{s}$$

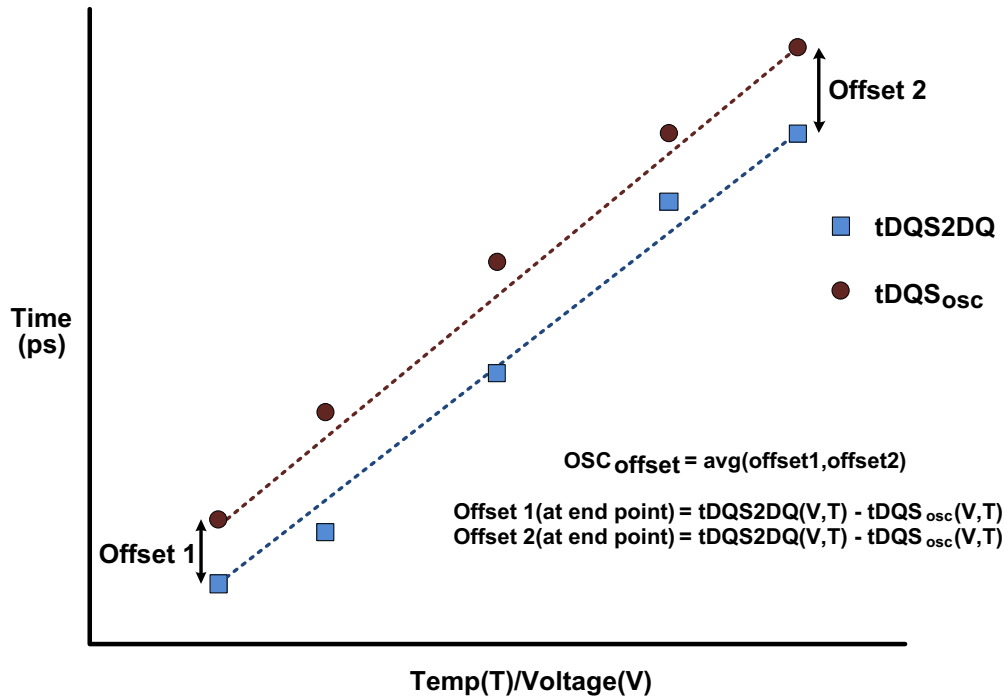
### 3.28.1. Interval Oscillator matching error

The interval oscillator matching error is defined as the difference between the DQS training ckt(interval oscillator) and the actual DQS clock tree across voltage and temperature.

#### Parameters:

- $t_{DQS2DQ}$ : Actual DQS clock tree delay
- $t_{DQSOSC}$ : Training ckt(interval oscillator) delay
- $OSC_{offset}$ : Average delay difference over voltage and temp(shown in the figure below)
- $OSC_{Match}$ : DQS oscillator matching error

**Figure - Interval oscillator offset ( $OSC_{offset}$ )**



$OSC_{Match}$  :

$$OSC_{Match} = [t_{DQS2DQ}(V,T) - t_{DQS_{OSC}}(V,T) - OSC_{offset}]$$

$t_{DQS_{OSC}}$  :

$$t_{DQS_{OSC}}(V,T) = \text{Runtime} / 2 * \text{Count}$$

**Table - DQS Oscillator Matching Error Specification**

Parameter	Symbol	Min	Max	Units	Notes
DQS Oscillator Matching Error	$OSC_{Match}$	-20	20	ps	1,2,3,4,5,6,7
DQS Oscillator Offset	$OSC_{offset}$	-100	100	ps	2,4,7

Note

1. The  $OSC_{Match}$  is the matching error per between the actual DQS and DQS interval oscillator over voltage and temp.
2. This parameter will be characterized or guaranteed by design.

3. The  $OSC_{Match}$  is defined as the following:

$$OSC_{Match} = [tDQS2DQ_{(V,T)} - tDQS_{OSC(V,T)} - OSC_{offset}]$$

Where  $tDQS2DQ_{(V,T)}$  and  $tDQS_{OSC(V,T)}$  are determined over the same voltage and temp conditions.

4. The runtime of the oscillator must be at least 200ns for determining  $tDQS_{OSC(V,T)}$

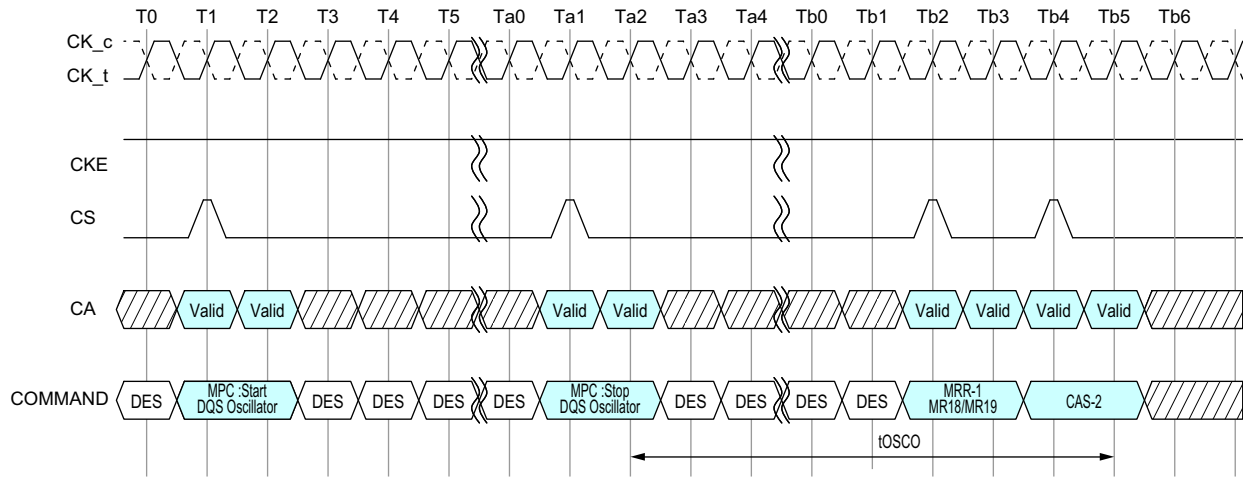
$$tDQS_{OSC(V,T)} = Runtime / 2 * Count$$

5. The input stimulus for  $tDQS2DQ$  will be consistent over voltage and temp conditions.  
6. The  $OSC_{offset}$  is the average difference of the endpoints across voltage and temp.  
7. These parameters are defined per channel.  
8.  $tDQS2DQ(V,T)$  delay will be the average of DQS to DQ delay over the runtime period.



### 3.28.2. DQS Interval Oscillator Readout Timing

OSC Stop to its counting value readout timing is shown in following figures:

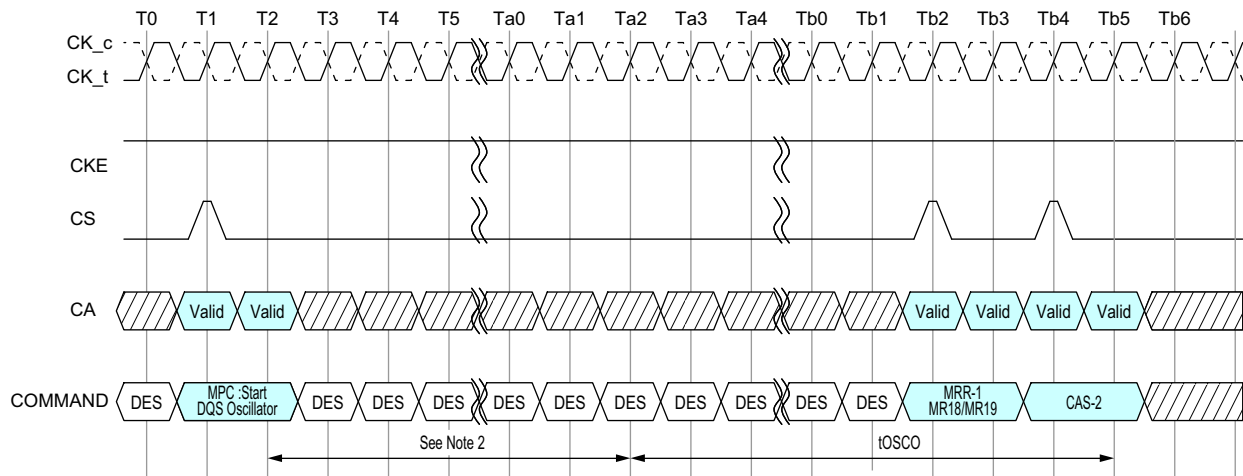
**Figure - In case of DQS Interval Oscillator is stopped by MPC Command**





- NOTES : 1. DQS interval timer run time setting : MR23 OP[7:0] = 00000000  
 2. DES commands are shown for ease of illustration; other commands may be valid at these times.

 DONT CARE  TIME BREAK

**Figure - In case of DQS Interval Oscillator is stopped by DQS interval timer**



- NOTES : 1. DQS interval timer run time setting : MR23 OP[7:0] ≠ 00000000  
 2. Setting counts of MR23  
 3. DES commands are shown for ease of illustration; other commands may be valid at these times.

 DONT CARE  TIME BREAK

### 3.29. Read Preamble Training

LPDDR4 READ Preamble Training is supported through the MPC function.

This mode can be used to train or read level the DQS receivers. Once READ Preamble Training is enabled by MR13[OP1]

= 1, the LPDDR4 DRAM will drive DQS<sub>t</sub> LOW, DQS<sub>c</sub> HIGH within tSDO and remain at these levels until an MPC DQ READ Training command is issued.

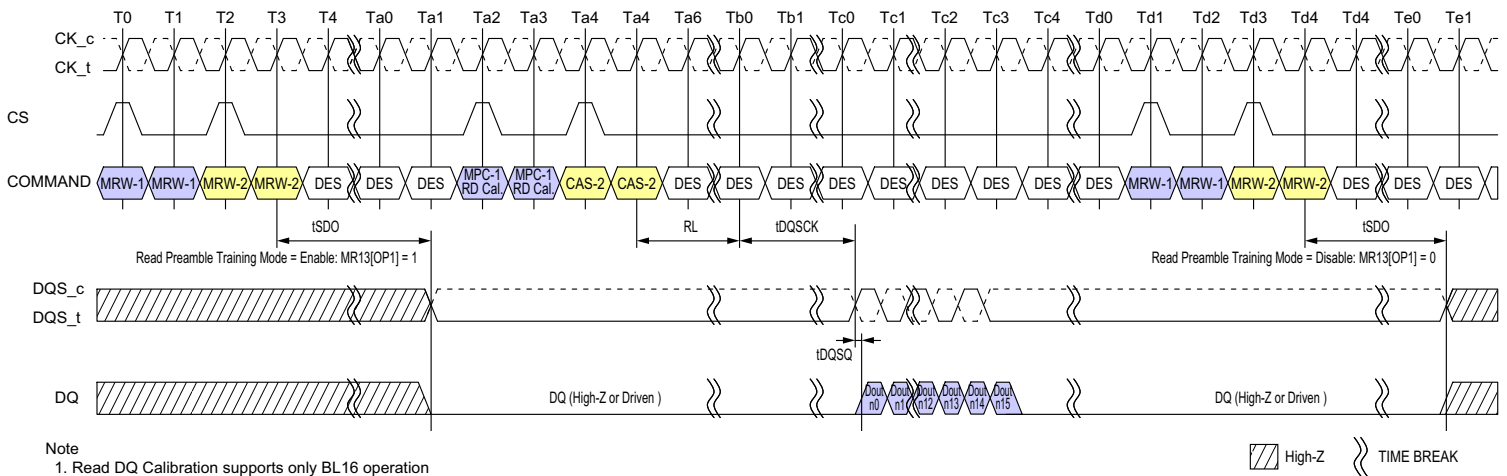
During READ Preamble Training the DQS preamble provided during normal operation will not be driven by the DRAM. Once the MPC DQ READ Training command is issued, the DRAM will drive DQS<sub>t</sub>/DQD<sub>c</sub> like a normal READ burst after RL. DRAM may or may not drive DQ[15:0] in this mode.

While in READ Preamble Training Mode, only READ DQ Calibration commands may be issued.

- Issue an MPC [RD DQ Calibration] command followed immediately by a CAS-2 command.
- Each time an MPC [RD DQ Calibration] command followed by a CAS-2 is received by the LPDDR4 SDRAM, a 16-bit data burst will, after the currently set RL, drive the eight bits programmed in MR32 followed by the eight bits programmed in MR40 on all I/O pins.
- The data pattern will be inverted for I/O pins with a '1' programmed in the corresponding invert mask mode register bit.
- Note that the pattern is driven on the DMI pins, but no data bus inversion function is enabled, even if Read DBI is enabled in the DRAM mode register.
- This command can be issued every tCCD seamlessly.
- The operands received with the CAS-2 command must be driven LOW.

READ Preamble Training is exited within tSDO after setting MR13[OP1] = 0.

**Figure - Read Preamble Training**



### 3.30. Multi Purpose Command (MPC)

LPDDR4-SDRAMs use the MPC command to issue a NOP and to access various training modes. The MPC command is initiated with CS, and CA[5:0] asserted to the proper state at the rising edge of CK, as defined by the Command Truth Table. The MPC command has seven operands (OP[6:0]) that are decoded to execute specific commands in the SDRAM. OP[6] is a special bit that is decoded on the first rising CK edge of the MPC command. When OP[6]=0 then the SDRAM executes a NOP (no operation) command, and when OP[6]=1 then the SDRAM further decodes one of several training commands.

When OP[6]=1 and when the training command includes a Read or Write operation, the MPC command must be fol-

lowed immediately by a CAS-2 command. For training commands that Read or Write the SDRAM, read latency (RL) and write latency (WL) are counted from the second rising CK edge of the CAS-2 command with the same timing relationship as any normal Read or Write command. The operands of the CAS-2 command following a MPC Read/Write command must be driven LOW. The following MPC commands must be followed by a CAS-2 command:

- Write FIFO
- Read FIFO
- Read DQ Calibration

All other MPC commands do not require a CAS-2 command, including:

- NOP
- Start DQS Interval Oscillator
- Stop DQS Interval Oscillator
- Start ZQ Calibration
- Latch ZQ Calibration

**Table - MPC Command Definition**

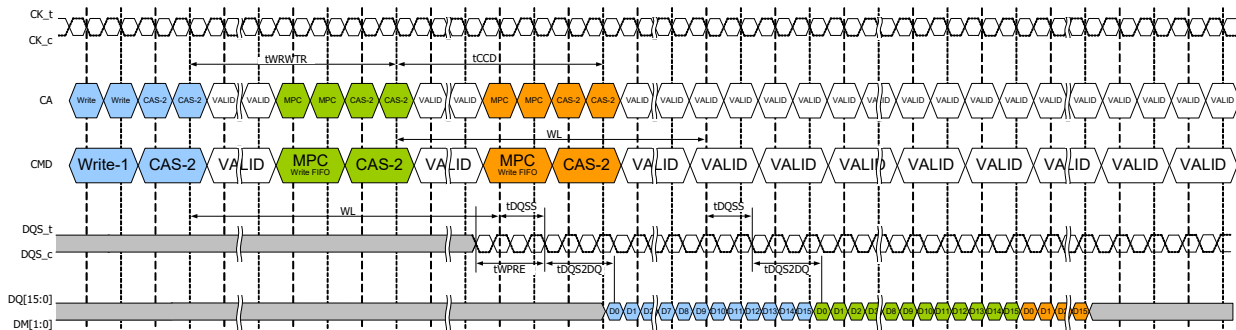
Command	SDR Command Pins (2)		DDR CA Pins (10)							CK_t edge	Notes
	CKE		CS_n	CA0	CA1	CA2	CA3	CA4	CA5		
	CK_t(n-1)	CK_t(n)									
Multi Purpose Command (MPC)	H	H	H	L	L	L	L	L	OP6	R1	1,2
			L	OP0	OP1	OP2	OP3	OP4	OP5	R2	

Function	Operand	Data	Notes
Training Modes	OP[6:0]	0XXXXXXB: NOP 1000001B: RD FIFO 1000011B: RD DQ Calibration (MR32/MR40) 1000101B: RFU 1000111B: WR FIFO 1001001B: RFU 1001011B: Start DQS Osc 1001101B: Stop DQS Osc 1001111B: ZQCal Start 1010001B: ZQCal Latch All Others: Reserved	1,2,3,4

**Notes:**

1. See command truth table for more information
2. MPC commands for Read or Write training operations must be immediately followed by CAS-2 command consecutively without any other commands in between. MPC command must be issued first before issuing the CAS-2 command.

**Figure - MPC [WR FIFO] Operation**



**Notes:**

1. MPC [WR FIFO] can be executed with a single bank or multiple banks active, during Refresh, or during SREF with CKE HIGH.
2. Write-1 to MPC is shown as an example of command-to-command timing for MPC. Timing from Write-1 to MPC [WR-FIFO] is tWRWTR.
3. Seamless MPC [WR-FIFO] commands may be executed by repeating the command every tCCD time.
4. MPC [WR-FIFO] uses the same command-to-data timing relationship (WL, tDQSS, tDQS2DQ) as a Write-1 command.
5. A maximum of 5 MPC [WR-FIFO] commands may be executed consecutively without corrupting FIFO data. The 6th MPC [WR-FIFO] command will overwrite the FIFO data from the first command. If fewer than 5 MPC [WR-FIFO] commands are executed, then the remaining FIFO locations will contain undefined data.
6. For the CAS-2 command following a MPC command, the CAS-2 operands must be driven "LOW."
7. To avoid corrupting the FIFO contents, MPC [RD-FIFO] must immediately follow MPC [WR-FIFO]/CAS-2 without any other command disturbing FIFO pointers in-between. FIFO pointers are disturbed by CKE Low, Write, Masked Write, Read, Read DQ Calibration and MRR. See Write Training session for more information on FIFO pointer behavior.





the FIFO pointer behavior.

6. For the CAS-2 command immediately following a MPC command, the CAS-2 operands must be driven "LOW."

7. DMI[1:0] signals will be driven if any of WR-DBI, RD-DBI, or DM is enabled in the mode registers. See Write Training section for more information on DMI behavior.

**Table - Timing Constraints for Training Commands**

Previous Command	Next Command	Minimum Delay	Unit	Notes
WR/MWR	MPC [WR FIFO]	tWRWTR	nCK	1
	MPC [RD FIFO]	Not Allowed	-	2
	MPC [RD DQ Calibration]	WL+RU(tDQSS(max)/tCK)+BL/2+RU(tWTR/tCK)	nCK	
RD/MRR	MPC [WR FIFO]	tRTW	nCK	4
	MPC [RD FIFO]	Not Allowed		2
	MPC [RD DQ Calibration]	tRTRRD	nCK	3
MPC [WR FIFO]	WR/MWR	Not Allowed		2
	MPC [WR FIFO]	tCCD	nCK	
	RD/MRR	Not Allowed		2
	MPC [RD FIFO]	WL+RU(tDQSS(max)/tCK)+BL/2+RU(tWTR/tCK)	nCK	
	MPC [RD DQ Calibration]	Not Allowed		2
MPC [RD FIFO]	WR/MWR	tRTW	nCK	4
	MPC [WR FIFO]	tRTW	nCK	4
	RD/MRR	tRTRRD	nCK	3
	MPC [RD FIFO]	tCCD	nCK	
	MPC [RD DQ Calibration]	tRTRRD	nCK	3
MPC [RD DQ Calibration]	WR/MWR	tRTW	nCK	4
	MPC [WR FIFO]	tRTW	nCK	4
	RD/MRR	tRTRRD	nCK	3
	MPC [RD FIFO]	Not Allowed		2
	MPC [RD DQ Calibration]	tCCD	nCK	

Notes:

1.  $tWRWTR = WL + BL/2 + RU(tDQSS(max)/tCK) + \max(RU(7.5ns/tCK), 8nCK)$
2. No commands are allowed between MPC [WR FIFO] and MPC [RD FIFO] except MRW commands related to training parameters.
3.  $tRTRRD = RL + RU(tDQSCK(max)/tCK) + BL/2 + RD(tRPST) + \max(RU(7.5ns/tCK), 8nCK)$
4. **tRTW (DQ ODT Disabled case; MR11 OP[2:0]=000b)**  
 $= RL + RU(tDQSCK(max)/tCK) + BL/2 - WL + tWPRES + RD(tRPST)$   
**tRTW (DQ ODT Enabled case; MR11 OP[2:0]≠000b)**  
 $= RL + RU(tDQSCK(max)/tCK) + BL/2 + RD(tRPST) - ODTLon - RD(tODTmin/tCK) + 1$

### 3.31. Thermal offset

Because of their tight thermal coupling with the LPDDR4 device, hot spots on an SOC can induce thermal gradients across the LPDDR4 device. As these hot spots may not be located near the device thermal sensor, the devices' temperature compensated self-refresh circuit may not generate enough refresh cycles to guarantee memory retention. To address this shortcoming, the controller can provide a thermal offset that the memory uses to adjust its TCSR circuit to ensure reliable operation.

This offset is provided through MR4(6:5) to either or to both the channels. This temperature offset may modify refresh behavior for the channel to which the offset is provided. It will take a max of 200us to have the change reflected in

MR4(2:0) for the channel to which the offset is provided. If the induced thermal gradient from the device temperature sensor location to the hot spot location of the controller is larger than 15 degrees C, then self-refresh mode will not reliably maintain memory contents.

To accurately determine the temperature gradient between the memory thermal sensor and the induced hot spot, the memory thermal sensor location must be provided to the LPDDR4 memory controller.

Support of thermal offset function is optional. Please refer to vendor datasheet to figure out if the function is supported or not.

### 3.32. Temperature Sensor

LPDDR4 devices feature a temperature sensor whose status can be read from MR4. This sensor can be used to determine an appropriate refresh rate, determine whether AC timing de-rating is required in the elevated temperature range, and/or monitor the operating temperature. Either the temperature sensor or the device TOPER may be used to determine whether operating temperature requirements are being met.

LPDDR4 devices shall monitor device temperature and update MR4 according to tTSI. Upon exiting self-refresh or power-down, the device temperature status bits shall be no older than tTSI.

When using the temperature sensor, the actual device case temperature may be higher than the TOPER specification that applies for the standard or elevated temperature ranges. For example, TCASE may be above 85°C when MR4[2:0] equals `b011. LPDDR4 devices shall allow for 2°C temperature margin between the point at which the device updates the MR4 value and the point at which the controller re-configures the system accordingly. In the case of tight thermal coupling of the memory device to external hot spots, the maximum device temperature might be higher than what is indicated by MR4.

To assure proper operation using the temperature sensor, applications should consider the following factors:

- TempGradient is the maximum temperature gradient experienced by the memory device at the temperature of interest over a range of 2°C.
- ReadInterval is the time period between MR4 reads from the system.
- TempSensorInterval (tTSI) is maximum delay between internal updates of MR4.
- SysRespDelay is the maximum time between a read of MR4 and the response by the system.

In order to determine the required frequency of polling MR4, the system shall use the maximum TempGradient and the maximum response time of the system using the following equation:

$$\text{TempGradient} \times (\text{ReadInterval} + \text{tTSI} + \text{SysRespDelay}) \leq 2\text{C}$$

**Table - Temperature Sensor**

Parameter	Symbol	Max/Min	Value	Unit	Notes
System Temperature Gradient	TempGradient	Max	System Dependent	°C/s	
MR4 Read Interval	ReadInterval	Max	System Dependent	ms	
Temperature Sensor Interval	tTSI	Max	32	ms	

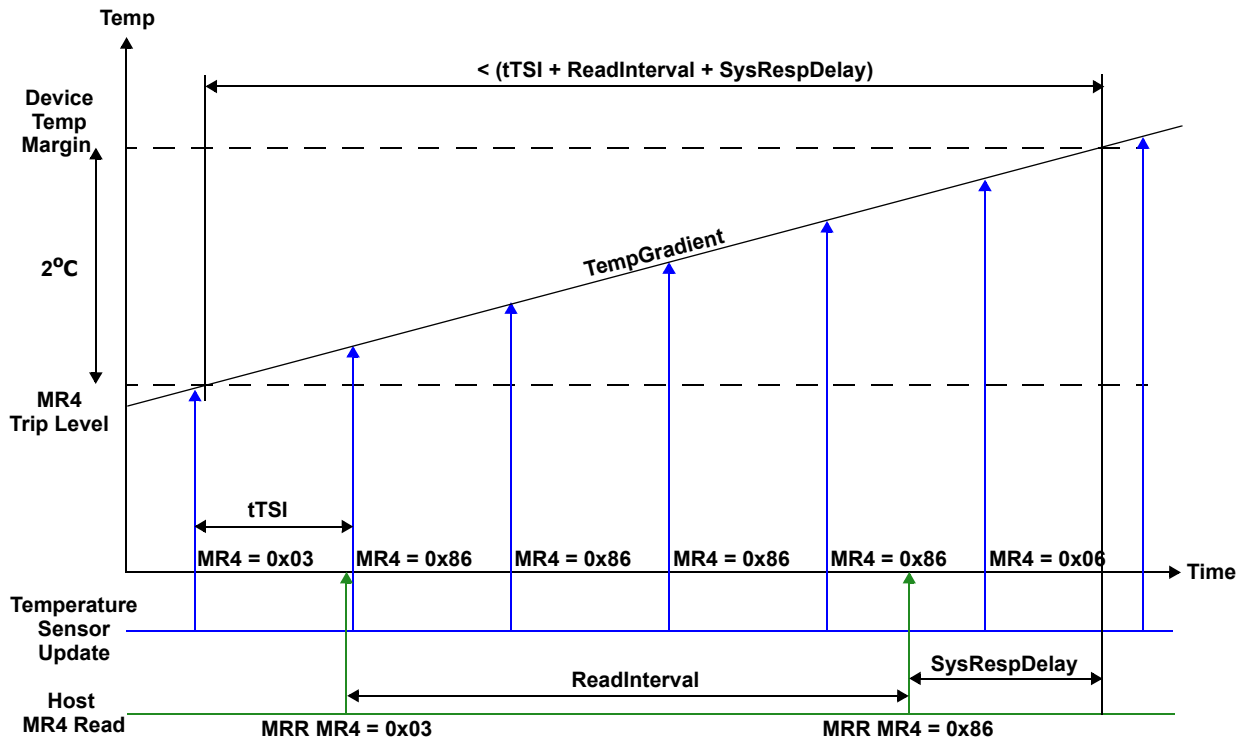
Parameter	Symbol	Max/Min	Value	Unit	Notes
System Response Delay	SysRespDelay	Max	System Dependent	ms	
Device Temperature Margin	TempMargin	Max	2	°C	

For example, if TempGradient is 10°C/s and the SysRespDelay is 1 ms:

$$(10^\circ\text{C/s}) \times (\text{ReadInterval} + 32\text{ms} + 1\text{ms}) \leq 2^\circ\text{C}$$

In this case, ReadInterval shall be no greater than 167ms.

**Figure - Temp sensor Timing**



### 3.33. ZQ Calibration

The MPC command is used to initiate ZQ Calibration, which calibrates the output driver impedance across process, temperature, and voltage. ZQ Calibration occurs in the background of device operation, and is designed to eliminate any need for coordination between channels (i.e. it allows for channel independence).

There are two ZQ Calibration modes initiated with the MPC command: ZQCal Start, and ZQCal Latch. ZQCal Start initiates the SDRAM's calibration procedure, and ZQCal Latch captures the result and loads it into the SDRAM's drivers.

A ZQCal Start command may be issued anytime the LPDDR4-SDRAM is not in a power-down state. A ZQCal Latch Command may be issued anytime outside of power-down after tZQCAL has expired and all DQ bus operations have completed. The CA Bus must maintain a Deselect state during tZQLAT to allow CA ODT calibration settings to be updated. The following mode register fields that modify I/O parameters cannot be changed following a ZQCal Start command and before tZQCAL has expired:

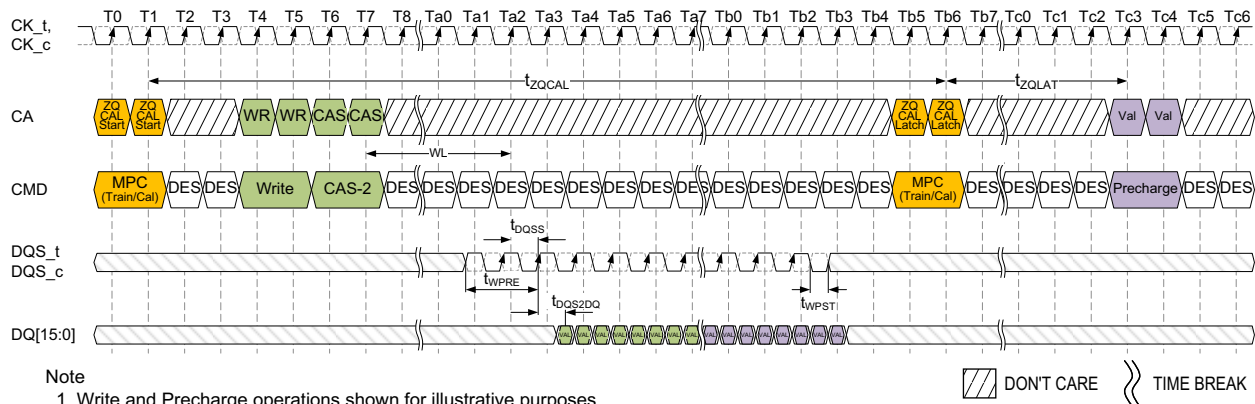
- PU-Cal (Pull-up Calibration VOH Point)
- PDDS (Pull Down Drive Strength and Rx Termination)
- DQ-ODT (DQ ODT Value)
- CA-ODT (CA ODT Value)

### 3.33.1. ZQCal Reset

The ZQCal Reset command resets the output impedance calibration to a default accuracy of +/- 30% across process, voltage, and temperature. This command is used to ensure output impedance accuracy to +/- 30% when ZQCal Start and ZQCal Latch commands are not used.

The ZQCal Reset command is executed by writing MR10-OP[0]=1B.

**Figure - ZQCal Timing**



Note

1. Write and Precharge operations shown for illustrative purposes. Any single or multiple valid commands may be executed within the tZQCAL time and prior to latching the results.
2. Before the ZQ-Latch command can be executed, any prior commands utilizing the DQ bus must have completed. Write commands with DQ Termination must be given enough time to turn off the DQ-ODT before issuing the ZQ-Latch command. See the ODT section for ODT timing.

### 3.33.2. Multi-Channel Considerations

The LPDDR4-SDRAM includes a single ZQ pin and associated ZQ Calibration circuitry. Calibration values from this circuit will be used by both channels according to the following protocol:

1. ZQCal Start commands may be issued to either or both channels.
2. ZQCal Start commands may be issued when either or both channels are executing other commands and other commands may be issued during tZQCAL.
3. ZQCal Start commands may be issued to both channels simultaneously.
4. The ZQCal Start command will begin the calibration unless a previously requested ZQ calibration is in progress.
5. If a ZQCal Start command is received while a ZQ calibration is in progress on the SDRAM, the ZQCal Start command will be ignored and the in-progress calibration will not be interrupted.
6. ZQCal Latch commands are required for each channel.
7. ZQCal Latch commands may be issued to both channels simultaneously.

8. ZQCal Latch commands will latch results of the most recent ZQCal Start command provided tZQCAL has been met.
9. ZQCal Latch commands which do not meet tZQCAL will latch the results of the most recently completed ZQ calibration.
10. ZQ Reset MRW commands will only reset the calibration values for the channel issuing the command.

In compliance with complete channel independence, either channel may issue ZQCal Start and ZQCal Latch commands as needed without regard to the state of the other channel.

### 3.33.2.1. ZQ External Resistor, Tolerance, and Capacitive Loading

To use the ZQ calibration function, a 240 ohm +/- 1% tolerance external resistor must be connected between the ZQ pin and VDDQ.

If the system configuration shares the CA bus to form a x32 (or wider) channel, the ZQ pin of each die's x16 channel shall use a separate ZQCal resistor.

If the system configuration has more than one rank, and if the ZQ pins of both ranks are attached to a single resistor, then the SDRAM controller must ensure that the ZQ Cal's don't overlap.

The total capacitive loading on the ZQ pin must be limited to 25pF.

Example: If a system configuration shares a CA bus between 'n' channels to form a n \* 16 wide bus, and no means are available to control the ZQCal separately for each channel (i.e. separate CS, CKE, or CK), then each x16 channel must have a separate ZQCal resistor.

Example: For a x32, two rank system, each x16 channel must have its own ZQCal resistor, but the ZQCal resistor can be shared between ranks on each x16 channel. In this configuration, the CS signal can be used to ensure that the ZQCal commands for Rank[0] and Rank[1] don't overlap.

### 3.33.2.2. ZQ Wiring for Byte-mode PKG including mixed configuration

Standard LPDDR4 package ballmaps allocate one ZQ ball per die. Byte-mode packages potentially support more die for higher package memory density. In order to use ballmaps developed for Standard LPDDR4, an alternate ZQ ball wiring strategy is employed when packages contain Byte-mode devices as shown in Figure in section 2.1.

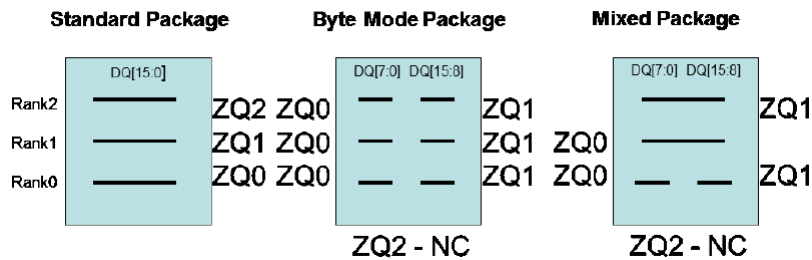
Since the wiring strategy for Byte-mode and Mixed packages shares a single ZQ resistor among ranks, applications must ensure that the ZQ cal's do not overlap. (See section 4.33.2.1)

Below are specific wiring notes for dual channel (x32) LPDDR4 packages

1. For packages using only standard devices
  - ZQ0 is connected to rank 0 DRAM
  - ZQ1 is connected to rank 1 DRAM (if present)
  - ZQ2 is connected to rank 2 DRAM (if present)
2. For packages using only byte-mode devices
  - ZQ0 is connected to all lower byte[7:0] or upper byte [15:8] DRAM(s)
  - ZQ1 is connected to opposite byte of all DRAM(s) from those connected to ZQ0
  - ZQ2 is NC
3. For packages using both standard and byte-mode devices

- ZQ0 is connected to all lower byte[7:0] or upper byte [15:8] DRAM(s)
- ZQ1 is connected to opposite byte of all DRAM(s) from those connected to ZQ0
- Standard DRAM(s) may be connected to either ZQ0 or ZQ1
- ZQ2 is NC

Multi-rank packages containing Byte-mode devices place additional loading on the I/O and power topologies and therefore may not be appropriate for all application environments.



### 3.34. Pull-down and Pull-up Driver Characteristics and Calibration Point

**Table - Pull-down Driver Characteristics, with ZQ Calibration**

R <sub>ONPD,nom</sub>	Resistor	Min	Nom	Max	Unit
40 Ohm	R <sub>ON40PD</sub>	0.90	1.0	1.10	RZQ/6
48 Ohm	R <sub>ON48PD</sub>	0.90	1.0	1.10	RZQ/5
60 Ohm	R <sub>ON60PD</sub>	0.90	1.0	1.10	RZQ/4
80 Ohm	R <sub>ON80PD</sub>	0.90	1.0	1.10	RZQ/3
120 Ohm	R <sub>ON120PD</sub>	0.90	1.0	1.10	RZQ/2
240 Ohm	R <sub>ON240PD</sub>	0.90	1.0	1.10	RZQ/1

Notes:

1. All values are after ZQ calibration. Without ZQ Calibration RONPD values are +/- 30%

**Table - Pull-up Driver Characteristics, with ZQ Calibration**

VOH <sub>PU,nom</sub>	VOH,nom(mV)	Min	Nom	Max	Unit
VDDQ*0.5	300	0.90	1.0	1.10	VOH,nom
VDDQ*0.6	360	0.90	1.0	1.10	VOH,nom

Notes:

1. All values are after ZQ calibration. Without ZQ Calibration VOH,nom values are +/- 30%
2. VOH,nom (mV) values are based on a nominal VDDQ=0.6V.

**Table - Valid Calibration Points**

VOH <sub>PU,nom</sub>	ODT Values					
	240	120	80	60	48	40
VDDQ*0.5	Valid	Valid	Valid	Valid	Valid	Valid
VDDQ*0.6	DNU	Valid	DNU	Valid	DNU	DNU

Notes:

1. Once the output is calibrated for a given VOH(nom) calibration point, the ODT value may be changed without recalibration.
2. If the VOH(nom) calibration point is changed, then re-calibration is required.
3. DNU = Do Not Use

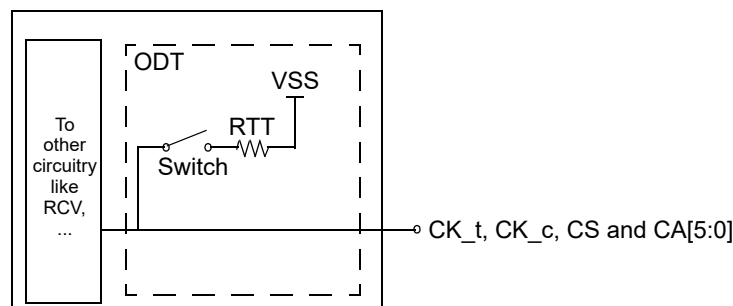
### 3.35. Command/Address Bus On Die Termination

ODT (On-Die Termination) is a feature of the LPDDR4 SDRAM that allows the SDRAM to turn on/off termination resistance for CK\_t, CK\_c, CS and CA[5:0] signals without the ODT control pin.

The ODT feature is designed to improve signal integrity of the memory channel by allowing the DRAM controller to turn on and off termination resistance for any target DRAM devices via Mode Register setting.

A simple functional representation of the DRAM ODT feature is shown in the Figure below

**Figure - Functional Representation of CA ODT**



#### 3.35.1. ODT Mode Register and ODT State Table

ODT termination values are set and enabled via MR11. The CA bus (CK\_t, CK\_c, CS, CA[5:0]) ODT resistance values are set by MR11 OP[6:4]. The default state for the CA is ODT disabled.

ODT is applied on the CA bus to the CK\_t, CK\_c, CS and CA[5:0] signals. Only one termination load will be present even if multiple devices are sharing the command signals. In a multirank system, the terminating rank should be trained first, followed by the non-terminating rank(s).

**Table - Command Bus ODT State**

ODTE-CA MR11[6:4]	ODTD-CA MR22[5]	ODTF-CK MR22[3]	ODTF-CS MR22[4]	ODT State for CA	ODT State for CK_t/CK_c	ODT State for CS
Disabled <sup>1</sup>	Valid <sup>2</sup>	Valid <sup>2</sup>	Valid <sup>2</sup>	Off	Off	Off
Valid <sup>2</sup>	0	0	0	On	On	On
Valid <sup>2</sup>	0	0	1	On	On	Off
Valid <sup>2</sup>	0	1	0	On	Off	On
Valid <sup>2</sup>	0	1	1	On	Off	Off
Valid <sup>2</sup>	1	0	0	Off	On	On
Valid <sup>2</sup>	1	0	1	Off	On	Off
Valid <sup>2</sup>	1	1	0	Off	Off	On
Valid <sup>2</sup>	1	1	1	Off	Off	Off

Notes:

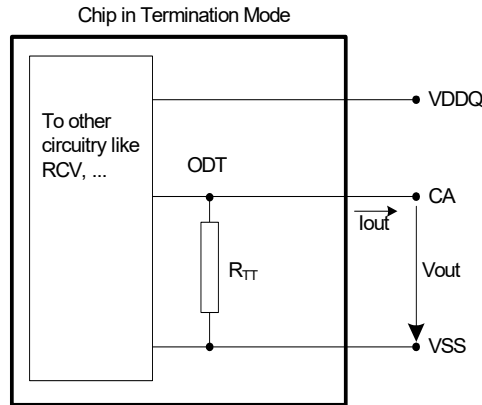
1. Default value
2. "Valid" means "0 or 1"
2. The state of ODT\_CA is not changed when the DRAM enters power-down mode. This maintains termination for alternate ranks in multi-rank systems.

### 3.35.2. ODT Mode Register and ODT characteristics

A functional representation of the on-die termination is shown in the figure below.

$$RTT = V_{out} / |I_{out}|$$

**Figure - CA On Die Termination**



**Table - ODT DC Electrical Charanteristics, assuming RZQ=240Ω +/- 1% over the entire operating temperature range after a proper ZQ calibration up to 3200Mbps**

MR11 OP[6:4]	RTT	Vout	Min	Nom	Max	Unit	Notes
001	240Ω	VOLdc=0.20*VDDQ	0.8	1.0	1.1	RZQ	1,2,3
		VOMdc=0.50*VDDQ	0.9	1.0	1.1		1,2,3
		VOHdc=0.75*VDDQ	0.9	1.0	1.3		1,2,3
010	120Ω	VOLdc=0.20*VDDQ	0.8	1.0	1.1	RZQ/2	1,2,3
		VOMdc=0.50*VDDQ	0.9	1.0	1.1		1,2,3
		VOHdc=0.75*VDDQ	0.9	1.0	1.3		1,2,3
011	80Ω	VOLdc=0.20*VDDQ	0.8	1.0	1.1	RZQ/3	1,2,3
		VOMdc=0.50*VDDQ	0.9	1.0	1.1		1,2,3
		VOHdc=0.75*VDDQ	0.9	1.0	1.3		1,2,3
100	60Ω	VOLdc=0.20*VDDQ	0.8	1.0	1.1	RZQ/4	1,2,3
		VOMdc=0.50*VDDQ	0.9	1.0	1.1		1,2,3
		VOHdc=0.75*VDDQ	0.9	1.0	1.3		1,2,3
101	48Ω	VOLdc=0.20*VDDQ	0.8	1.0	1.1	RZQ/5	1,2,3
		VOMdc=0.50*VDDQ	0.9	1.0	1.1		1,2,3
		VOHdc=0.75*VDDQ	0.9	1.0	1.3		1,2,3
110	40Ω	VOLdc=0.20*VDDQ	0.8	1.0	1.1	RZQ/6	1,2,3
		VOMdc=0.50*VDDQ	0.9	1.0	1.1		1,2,3
		VOHdc=0.75*VDDQ	0.9	1.0	1.3		1,2,3
Mismatch CA-CA within byte		0.50*VDDQ	-		2	%	1,2,4



Notes:

1. The tolerance limits are specified after calibration with stable voltage and temperature. For the behavior of the tolerance limits if temperature or voltage changes after calibration, see following section on voltage and temperature sensitivity.
2. Pull-dn ODT resistors are recommended to be calibrated at 0.50\*VDDQ. Other calibration schemes may be used to achieve the linearity spec shown above, e.g. calibration at 0.75\*VDD2 and 0.2\*VDD2.
3. Measurement definition for RTT: **TBD**
4. CA to CA mismatch within clock group (CA,CS) variation for a given component including CK\_t and CK\_c (characterized).

$$CA - CA_{mismatch} = \frac{RODI(max) - RODI(min)}{RODI(avg)}$$

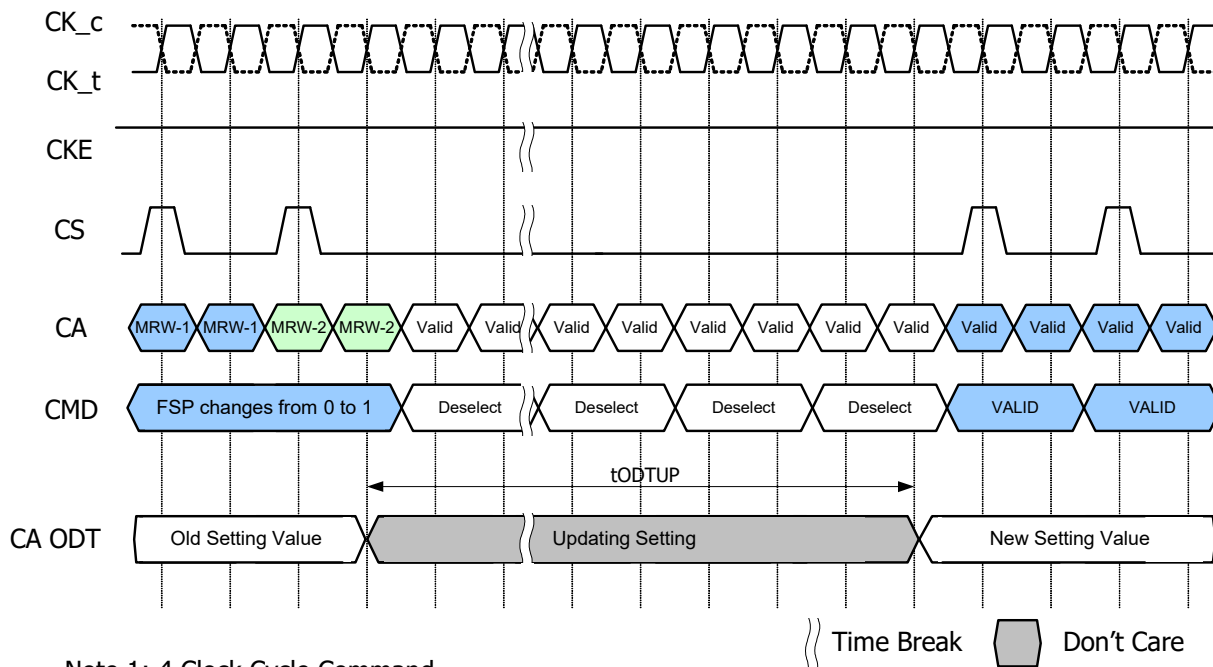
Notes:

1. As of publication of this document, under discussion by the formulating committee.

### 3.35.3. ODT for Command/Address update time

ODT for Command/Address update time after Mode Register set are shown in the figure below

**Figure - CA ODT setting update timing in 4 Clock Cycle Command**



Note 1: 4 Clock Cycle Command

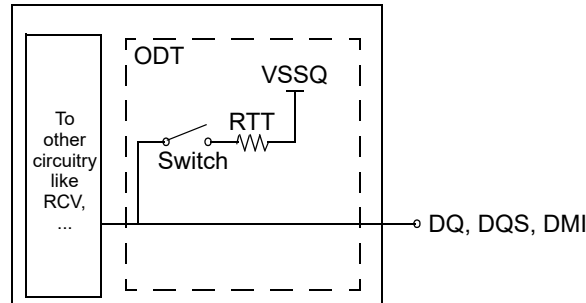
### 3.36. DQ On-die Termination

ODT (On-Die Termination) is a feature of the LPDDR4 SDRAM that allows the DRAM to turn on/off termination resistance for each DQ, DQS\_t, DQS\_c and DMI signals without the ODT control pin. The ODT feature

is designed to improve signal integrity of the memory channel by allowing the DRAM controller to turn on and off termination resistance for any target DRAM devices during Write operation.

The ODT feature is off and cannot be supported in Power Down and Self-Refresh modes.

A simple functional representation of the DRAM ODT feature is shown in following Figure.



**Figure - Functional Representation of DQ ODT**

The switch is enabled by the internal ODT control logic, which uses the Write-1 command and other mode register control information. The value of RTT is determined by the settings of Mode Register bits.

### 3.36.1. ODT Mode Register

The ODT Mode is enabled if MR11 OP[2:0] are non zero. In this case, the value of RTT is determined by the settings of those bits. The ODT Mode is disabled if MR11 OP[2:0] = 000b.

### 3.36.2. Asynchronous ODT

When ODT Mode is enabled in MR11 OP[2:0], DRAM ODT is always Hi-Z. DRAM ODT feature is automatically turned ON asynchronously based on the Write-1 or Mask Write-1 command that DRAM samples. After the write burst is complete, DRAM ODT featured is automatically turned OFF asynchronously.

Following timing parameters apply when DRAM ODT mode is enabled::

- ODTLon, tODTon,min, tODTon,max
- ODTLoff, tODToff,min, tODToff,max

ODTLon is a synchronous parameter and it is the latency from CAS-2 command to tODTon reference. ODTLon latency is a fixed latency value for each speed bin. Each speed bin has a different ODTLon latency. Minimum RTT turn-on time (tODTon,min) is the point in time when the device termination circuit leaves high impedance state and ODT resistance begins to turn on.

Maximum RTT turn on time (tODTon,max) is the point in time when the ODT resistance is fully on.

tODTon,min and tODTon,max are measured once ODTLon latency is satisfied from CAS-2 command.

ODTLoff is a synchronous parameter and it is the latency from CAS-2 command to tODToff reference.

ODT<sub>Loff</sub> latency is a fixed latency value for each speed bin. Each speed bin has a different ODT<sub>Loff</sub> latency. Minimum RTT turn-off time (tODT<sub>off,min</sub>) is the point in time when the device termination circuit starts to turn off the ODT resistance.

Maximum ODT turn off time (tODT<sub>off,max</sub>) is the point in time when the on-die termination has reached high impedance.

tODT<sub>off,min</sub> and tODT<sub>off,max</sub> are measured once ODT<sub>Loff</sub> latency is satisfied from CAS-2 command.

**Table - ODT Timings**

ODT <sub>Lon</sub> Latency <sup>a)</sup>		ODT <sub>Loff</sub> Latency <sup>b)</sup>		Lower Frequency Limit (>)	Upper Frequency Limit (≤)
WL Set "A"	WL Set "B"	WL Set "A"	WL Set "B"		
N/A	N/A	N/A	N/A	10	266
N/A	N/A	N/A	N/A	266	533
N/A	6	N/A	22	533	800
4	12	20	28	800	1066
4	14	22	32	1066	1333
6	18	24	36	1333	1600
6	20	26	40	1600	1866
8	24	28	44	1866	2133
nCK	nCK	nCK	nCK	MHz	MHz

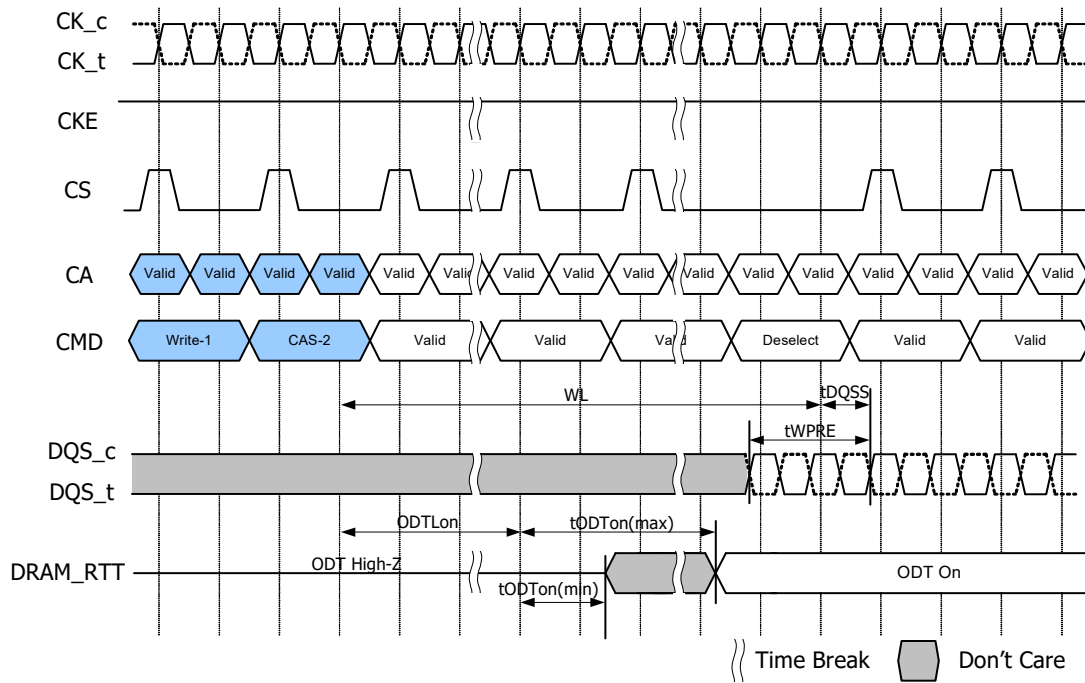
a. ODT<sub>Lon</sub> is referenced from CAS-2 command. See timing diagram examples below.

b. ODT<sub>Loff</sub> is shown in table assumes BL=16. For BL32, 8 tCK should be added.

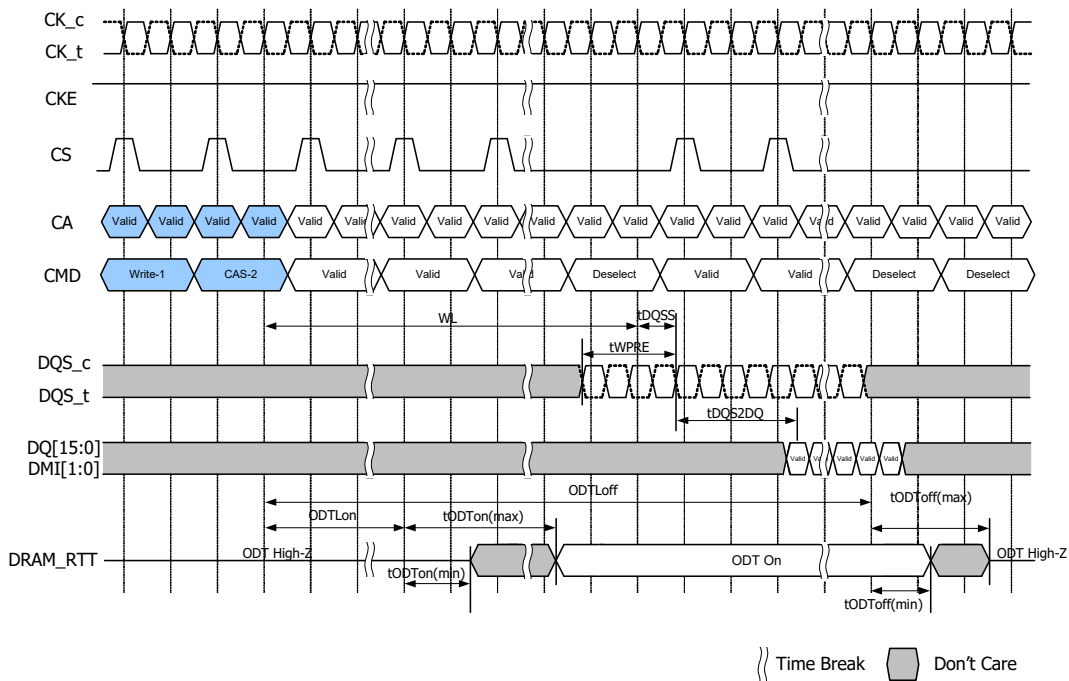
**Table - Asynchronous ODT turn on and turn off timing**

Parameter	800~2133MHz	Unit
tODT <sub>on,min</sub>	1.5	ns
tODT <sub>on,max</sub>	3.5	ns
tODT <sub>off,min</sub>	1.5	ns
tODT <sub>off,max</sub>	3.5	ns

**Figure - Asynchronous ODT<sub>ON</sub> Timing Example;  $t_{WPRE} = 2 t_{CK}$ ,  $t_{DQSS} = \text{Nominal}$**



**Figure - Asynchronous ODT<sub>OFF</sub> Timing Example,  $t_{WPRE} = 2 nCK$ ,  $t_{DQSS} = \text{Nominal}$**



### 3.36.3. ODT during Write Leveling

If ODT is enabled in MR11 OP[2:0], in Write Leveling mode, DRAM always provides the termination on DQS\_t/DQS\_c signals. DQ termination is always off in Write Leveling mode regardless.

**Table - DRAM Termination Function in Write Leveling Mode**

ODT Enabled in MR11	DQS_t/DQS_c termination	DQ termination
Disabled	OFF	OFF
Enabled	ON	OFF

### 3.37. On Die Termination for DQ, DQS and DMI

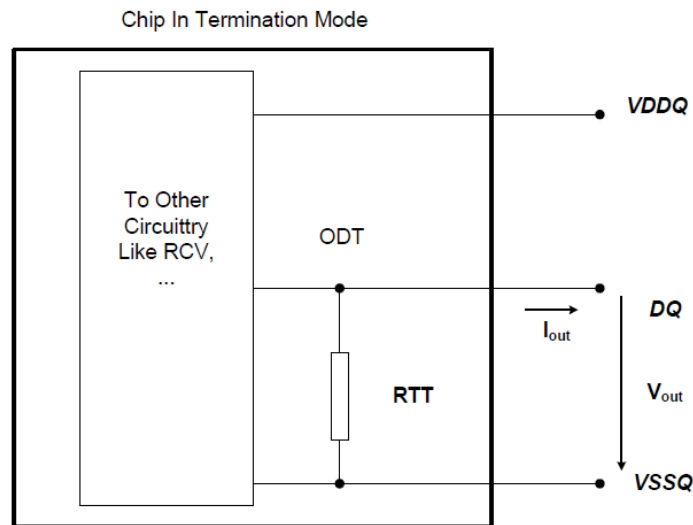
On-Die Termination effective resistance RTT is defined by MR bits MR11 OP[2:0].

ODT is applied to the DQ, DMI, DQS\_t and DQS\_c pins.

A functional representation of the on-die termination is shown in the figure below.

$$RTT = V_{out} / |I_{out}|$$

**Figure - DQ On Die Termination**



**Table - ODT DC Electrical Characteristics, assuming RZQ=240Ω +/- 1% over the entire operating temperature range after a proper ZQ calibration for up to 3200Mbps.**

MR11 OP[2:0]	RTT	Vout	Min	Nom	Max	Unit	Notes
001	240Ω	VOLdc=0.20*VDDQ	0.8	1.0	1.1	RZQ	1,2,3
		VOMdc=0.50*VDDQ	0.9	1.0	1.1		1,2,3
		VOHdc=0.75*VDDQ	0.9	1.0	1.3		1,2,3

MR11 OP[2:0]	RTT	Vout	Min	Nom	Max	Unit	Notes
010	120Ω	VOLdc=0.20*VDDQ	0.8	1.0	1.1	RZQ/2	1,2,3
		VOMdc=0.50*VDDQ	0.9	1.0	1.1		1,2,3
		VOHdc=0.75*VDDQ	0.9	1.0	1.3		1,2,3
011	80Ω	VOLdc=0.20*VDDQ	0.8	1.0	1.1	RZQ/3	1,2,3
		VOMdc=0.50*VDDQ	0.9	1.0	1.1		1,2,3
		VOHdc=0.75*VDDQ	0.9	1.0	1.3		1,2,3
100	60Ω	VOLdc=0.20*VDDQ	0.8	1.0	1.1	RZQ/4	1,2,3
		VOMdc=0.50*VDDQ	0.9	1.0	1.1		1,2,3
		VOHdc=0.75*VDDQ	0.9	1.0	1.3		1,2,3
101	48Ω	VOLdc=0.20*VDDQ	0.8	1.0	1.1	RZQ/5	1,2,3
		VOMdc=0.50*VDDQ	0.9	1.0	1.1		1,2,3
		VOHdc=0.75*VDDQ	0.9	1.0	1.3		1,2,3
110	40Ω	VOLdc=0.20*VDDQ	0.8	1.0	1.1	RZQ/6	1,2,3
		VOMdc=0.50*VDDQ	0.9	1.0	1.1		1,2,3
		VOHdc=0.75*VDDQ	0.9	1.0	1.3		1,2,3
Mismatch DQ-DQ within byte		0.50*VDDQ	-		2	%	1,2,4

**Notes:**

- The tolerance limits are specified after calibration with stable voltage and temperature. For the behavior of the tolerance limits if temperature or voltage changes after calibration, see following section on voltage and temperature sensitivity.
- Pull-dn ODT resistors are recommended to be calibrated at 0.50\*VDDQ. Other calibration schemes may be used to achieve the linearity spec shown above, e.g. calibration at 0.75\*VDDQ and 0.2\*VDDQ.
- Measurement definition for RTT: **TBD**
- DQ to DQ mismatch within byte variation for a given component including DQS\_t and DQS\_c (characterized).

$$DQ - DQ_{mismatch} = \frac{RODT(max) - RODT(min)}{RODT(avg)}$$

**Notes:**

- As of publication of this document, under discussion by the formulating committee.

### 3.38. Output Driver and Termination Register Temperature and Voltage Sensitivity

If temperature and/or voltage change after calibration, the tolerance limits widen according to the Tables shown below.

**Table - Output Driver and Termination Register Sensitivity Definition**

Resistor	Definition Point	Min	Max	Unit	Notes
R <sub>ONPD</sub>	0.50 x VDDQ	90-(dR <sub>on</sub> dT x  ΔT )-(dR <sub>on</sub> dV x  ΔV )	110+(dR <sub>on</sub> dT x  ΔT )+(dR <sub>on</sub> dV x  ΔV )	%	1,2
VOH <sub>PU</sub>	0.50 x VDDQ	90-(dVOHdT x  ΔT )-(dVOHdV x  ΔV )	110+(dVOHdT x  ΔT )+(dVOHdV x  ΔV )	%	1,2,5
R <sub>TT(I/O)</sub>	0.50 x VDDQ	90-(dR <sub>on</sub> dT x  ΔT )-(dR <sub>on</sub> dV x  ΔV )	110+(dR <sub>on</sub> dT x  ΔT )+(dR <sub>on</sub> dV x  ΔV )	%	1,2,3
R <sub>TT(In)</sub>	0.50 x VDDQ	90-(dR <sub>on</sub> dT x  ΔT )-(dR <sub>on</sub> dV x  ΔV )	110+(dR <sub>on</sub> dT x  ΔT )+(dR <sub>on</sub> dV x  ΔV )	%	1,2,4

**Note.**

- ΔT = T - T(@ Calibration), ΔV = V - V(@ Calibration)
- dR<sub>ON</sub>dT, dR<sub>ON</sub>dV, dVOHdT, dVOHdV, dR<sub>TT</sub>dV, and dR<sub>TT</sub>dT are not subject to production test but are verified by design and characterization.
- This parameter applies to Input/Output pin such as DQS, DQ and DMI.

4. This parameter applies to Input pin such as CK, CA and CS.
5. Refer to 3.34. Pull-down and Pull-up Driver Characteristics and Calibration Point for  $VOH_{PJ}$ .

**Table - Output Driver and Termination Register Temperature and Voltage Sensitivity**

Symbol	Parameter	Min	Max	Unit
$dR_{ONdT}$	$R_{ON}$ Temperature Sensitivity	0.00	0.75	%/°C
$dR_{ONdV}$	$R_{ON}$ Voltage Sensitivity	0.00	0.20	%/mV
$dVOHdT$	VOH Temperature Sensitivity	0.00	0.75	%/°C
$dVOHdV$	VOH Voltage Sensitivity	0.00	0.35	%/mV
$dR_{TTdT}$	$R_{TT}$ Temperature Sensitivity	0.00	0.75	%/°C
$dR_{TTdV}$	$R_{TT}$ Voltage Sensitivity	0.00	0.20	%/mV

### 3.39. Power Down Mode

#### 3.39.1. Power Down Entry and Exit

Power-down is asynchronously entered when CKE is driven LOW and CS is LOW. CKE must not go LOW while the following operations are in progress:

- Mode Register Read
- Mode Register Write
- Read
- Write
- $V_{ref}(CA)$  Range and Value setting via MRW
- $V_{ref}(DQ)$  Range and Value setting via MRW
- Command Bus Training mode Entering/Exiting via MRW
- VRCG High Current mode Entering/Exiting via MRW

And the LPDDR4 DRAM cannot be placed in power-down state during "Start DQS Interval Oscillator" operation.

CKE can go LOW while any other operations such as row activation, Precharge, Auto Precharge, or Refresh are in progress. The power-down IDD specification will not be applied until such operations are complete. Power-down entry and exit are shown in Figure "Basic Power-Down Entry and Exit Timing".

Entering power-down deactivates the input and output buffers, excluding CKE and  $Reset_n$ . To ensure that there is enough time to account for internal delay on the CKE signal path, CS input is required stable Low level and CA input level is don't care after CKE is driven LOW, this timing period is defined as  $t_{CKELCS}$ .

Clock input is required after CKE is driven LOW, this timing period is defined as  $t_{CKELCK}$ . CKE LOW will result in deactivation of all input receivers except  $Reset_n$  after  $t_{CKELCK}$  has expired. In power-down mode, CKE must be held LOW; all other input signals except  $Reset_n$  are "Don't Care". CKE LOW must be maintained until  $t_{CKE,min}$  is satisfied.

VDDQ can be turned off during power-down. Prior to exiting power-down, VDDQ must be within its minimum/maximum operating ranges.

No refresh operations are performed in power-down mode except Self-Refresh power-down. The maximum duration in non-Self-Refresh power-down mode is only limited by the refresh requirements outlined in the Refresh command section.

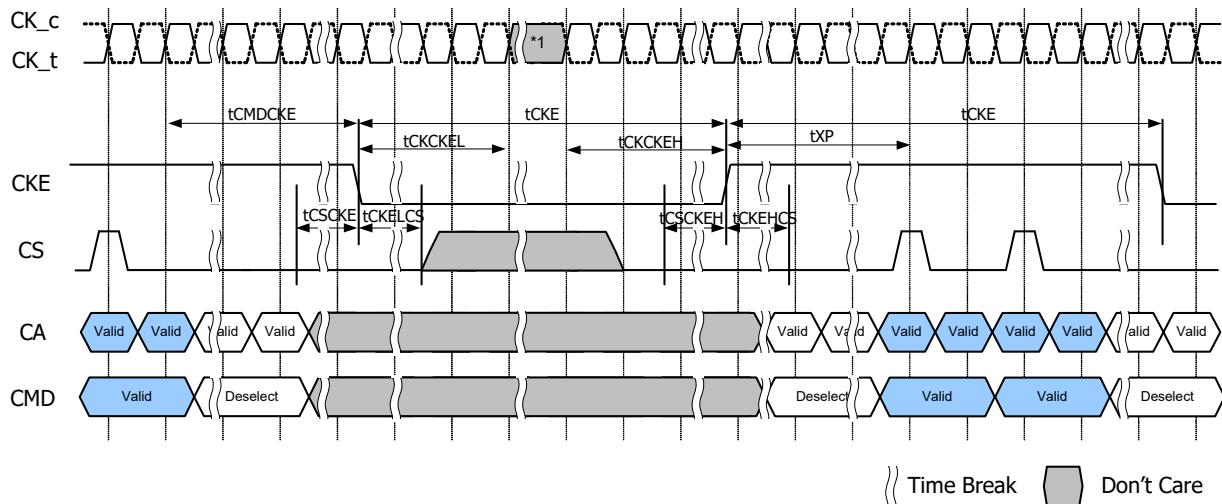
The power-down state is asynchronously exited when CKE is driven HIGH. CKE HIGH must be maintained until  $t_{CKE,min}$  is satisfied. A valid, executable command can be applied with power-down exit latency  $t_{XP}$  after CKE goes HIGH. Power-down exit latency is defined in the AC timing parameter table.

Clock frequency change or Clock Stop is inhibited during  $t_{CMDCKE}$ ,  $t_{CKELCK}$ ,  $t_{CKCKEH}$ ,  $t_{XP}$ ,  $t_{MRWCKEL}$  and  $t_{ZQCKE}$  periods.

If power-down occurs when all banks are idle, this mode is referred to as idle power-down. If power-down occurs when there is a row active in any bank, this mode is referred to as active power-down. And If power-down occurs when Self Refresh is in progress, this mode is referred to as Self Refresh power-down in which the internal refresh is continuing in the same way as Self Refresh mode.

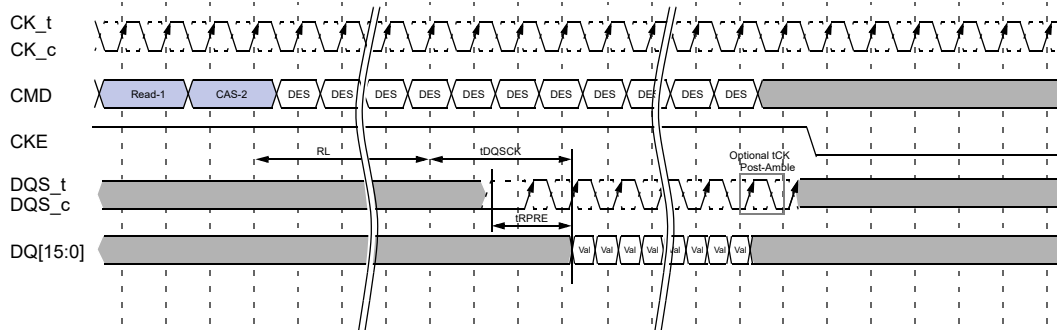
When CA, CK and/or CS ODT is enabled via MR11 OP[6:4] and also via MR22 or CA-ODT pad setting, the rank providing ODT will continue to terminate the command bus in all DRAM states including power-down.

**Figure - Basic Power-down Entry and Exit Timing**



1. Input clock frequency can be changed or the input clock can be stopped or floated during power-down, provided that upon exiting power-down, the clock is stable and within specified limits for a minimum of  $RU(t_{CKCKEH}/t_{CK})$  of stable clock prior to power-down exit and the clock frequency is between the minimum and maximum specified frequency for the speed grade in use.

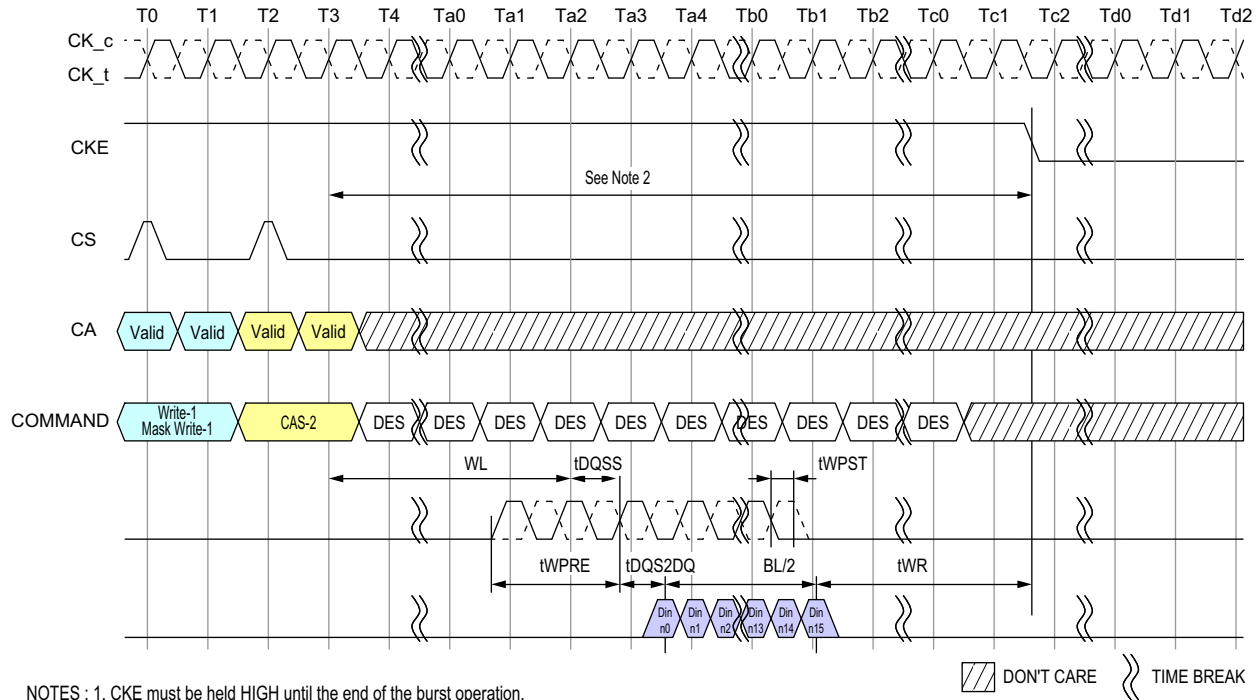
**Figure - Read and Read with Auto-precharge to Power-Down Entry**





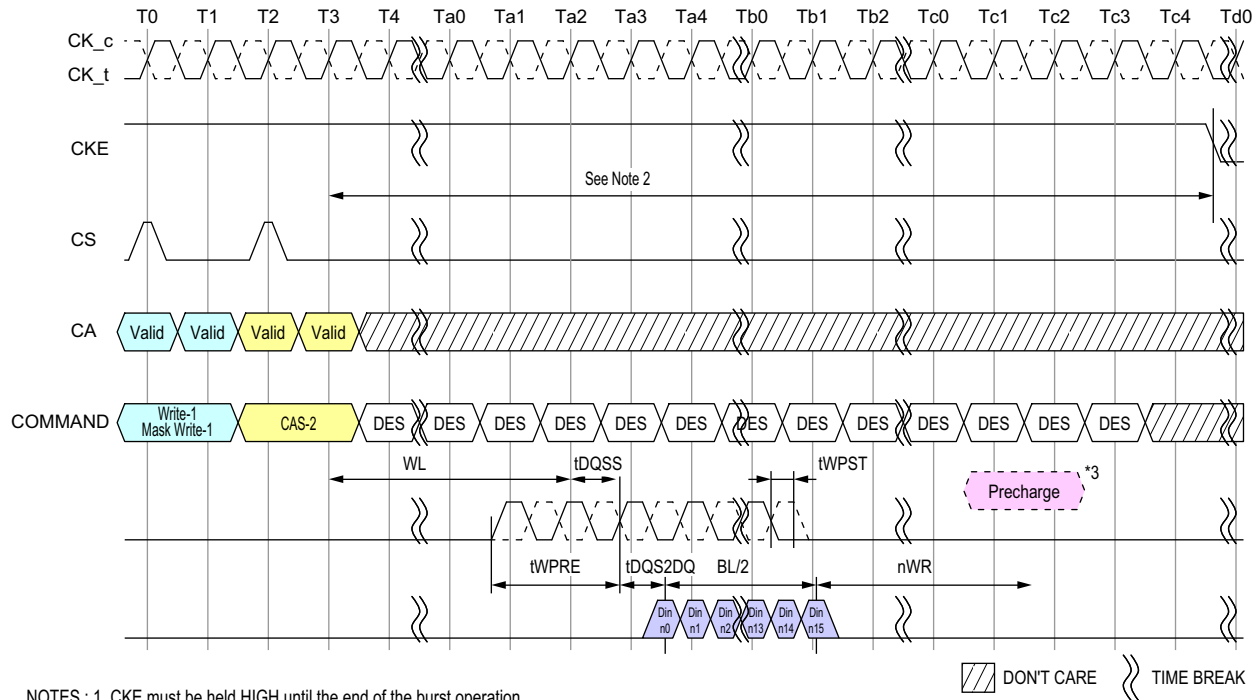
1. CKE must be held HIGH until the end of the burst operation.
2. Minimum Delay time from Read Command or Read with Auto Precharge Command to falling edge of CKE signal is as follows.
  - Read Post-amble = 0.5nCK : MR1 OP[7]=[0] :  $(RL \times tCK) + tDQSK(Max) + ((BL/2) \times tCK) + 1tCK$
  - Read Post-amble = 1.5nCK : MR1 OP[7]=[1] :  $(RL \times tCK) + tDQSK(Max) + ((BL/2) \times tCK) + 2tCK$

**Figure - Write and Mask Write to Power-Down Entry**



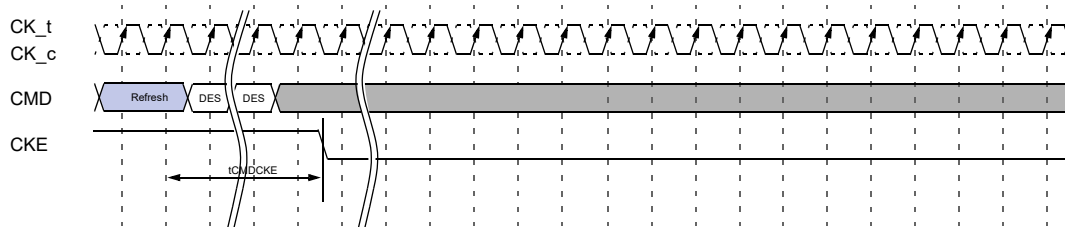
- NOTES :
1. CKE must be held HIGH until the end of the burst operation.
  2. Minimum Delay time from Write Command or Mask Write Command to falling edge of CKE signal is as follows.  
 $(WL \times tCK) + tDQSS(Max) + tDQS2DQ(Max) + ((BL/2) \times tCK) + tWR$
  3. This timing is applied regardless of DQ ODT Disable/Enable setting: MR11[OP2:0].
  4. This timing diagram only applies to the Write and Mask Write Commands without Auto Precharge.

**Figure - Write and Masked Write with Auto Precharge to Power-Down Entry**



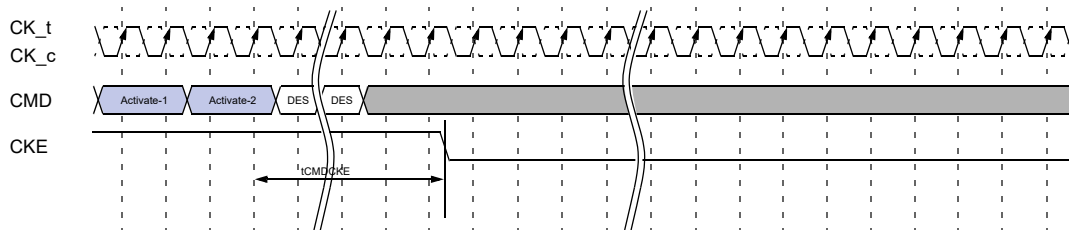
- NOTES : 1. CKE must be held HIGH until the end of the burst operation.  
 2. Delay time from Write with Auto Precharge Command or Mask Write with Auto Precharge Command to falling edge of CKE signal is more than  $(WL \times tCK) + tDQSS(Max) + tDQS2DQ(Max) + ((BL/2) \times tCK) + (nWR \times tCK) + (2 \times tCK)$   
 3. Internal Precharge Command  
 4. This timing is applied regardless of DQ ODT Disable/Enable setting: MR11[OP2:0].

**Figure - Refresh entry to Power-Down Entry**



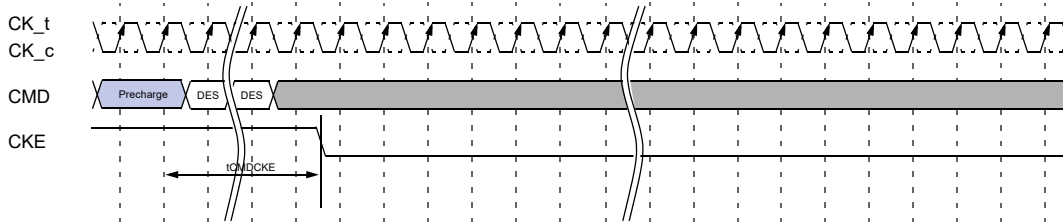
- Notes: 1. CKE must be held HIGH until tCMDCKE is satisfied.

**Figure - Activate Command to Power-Down Entry**



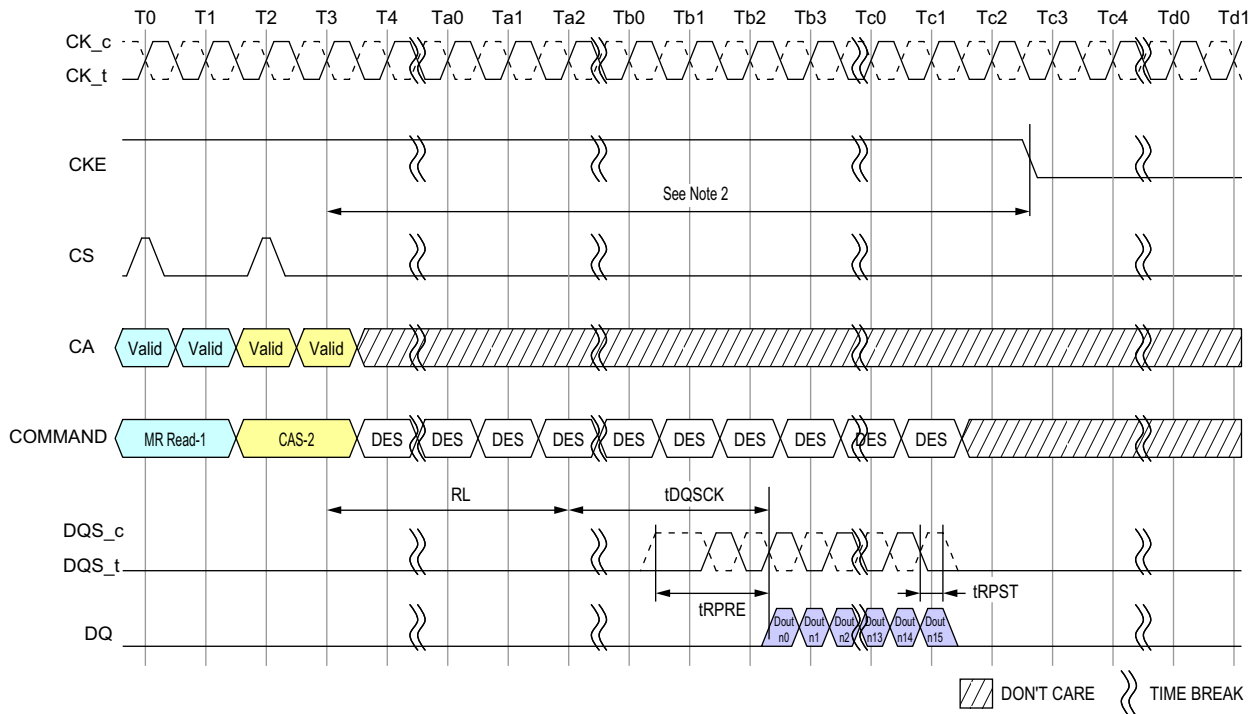
- Notes: 1. CKE must be held HIGH until tCMDCKE is satisfied.

**Figure - Precharge Command to Power-Down Entry**



Notes: 1. CKE must be held HIGH until tCMDCKE is satisfied.

**Figure - Mode Register Read to Power-Down Entry**



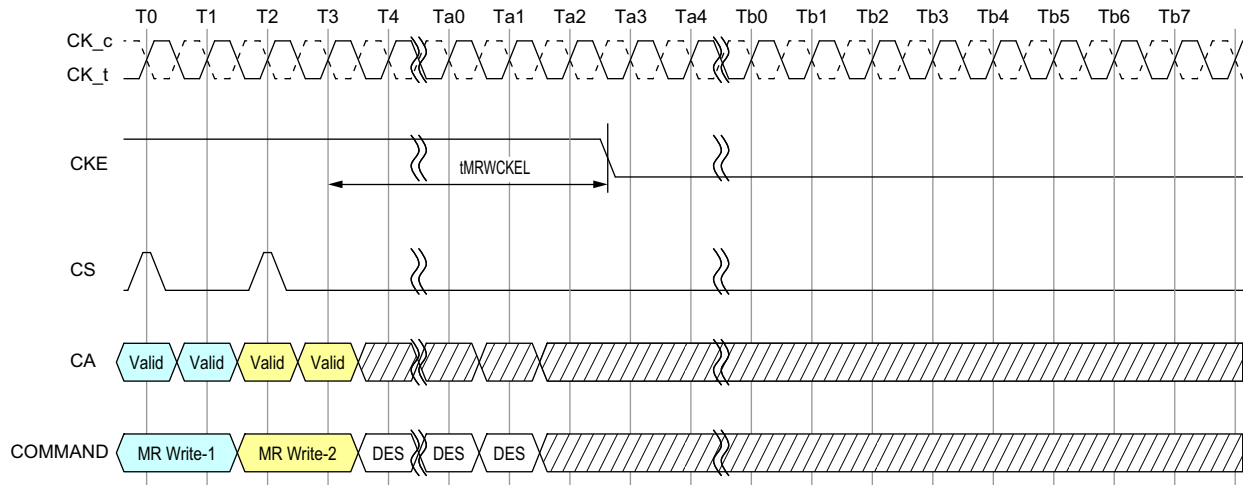
NOTES : 1. CKE must be held HIGH until the end of the burst operation.

2. Minimum Delay time from Mode Register Read Command to falling edge of CKE signal is as follows:


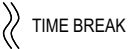
Read Post-amble = 0.5nCK : MR1 OP[7]=[0] :  $(RL \times tCK) + tDQSCK(Max) + ((BL/2) \times tCK) + 1tCK$

Read Post-amble = 1.5nCK : MR1 OP[7]=[1] :  $(RL \times tCK) + tDQSCK(Max) + ((BL/2) \times tCK) + 2tCK$

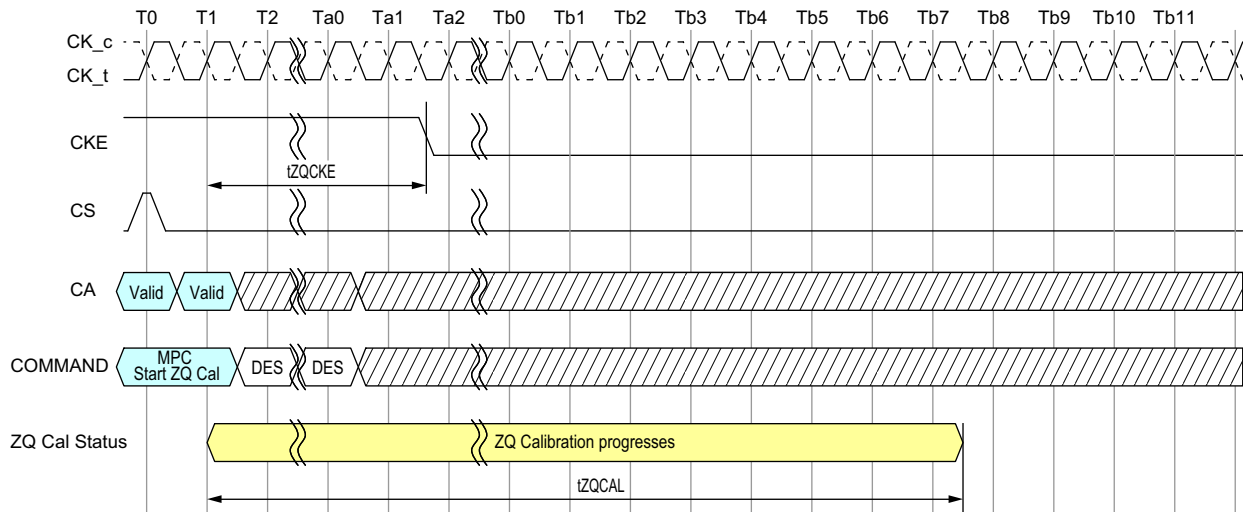
**Figure - MRW to Power-Down Entry**



- NOTES : 1. CKE must be held HIGH until tMRWCKEL is satisfied.  
 2. This timing is the general definition for Power Down Entry after Mode Register Write Command.  
 When a Mode Register Write Command changes a parameter or starts an operation that requires special timing longer than tMRWCKEL, that timing must be satisfied before CKE is driven low.  
 Changing the Vref(DQ) value is one example, in this case the appropriate Vref\_time-Short/Middle/Long must be satisfied.

 DONT CARE  TIME BREAK

**Figure - MPC ZQCAL\_start to Power-Down Entry**



- NOTES : 1. ZQ Calibration continues if CKE goes low after tZQCKE is satisfied.

 DONT CARE  TIME BREAK

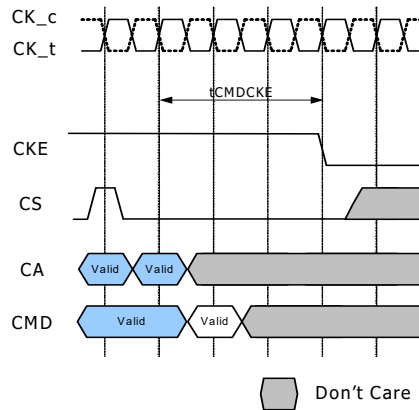
**Table - Power-Down AC Timing**

Parameter	Symbol	Min/Max	Data Rate	Units	Notes
<b>Power Down Timing</b>					
CKE minimum pulse width (HIGH and LOW pulse width)	tCKE	Min	Max(7.5ns, 4nCK)	-	
Delay from valid command to CKE input LOW	tCMDCKE	Min	Max(1.75ns, 3nCK)	ns	1
Valid Clock Requirement after CKE Input low	tCKELCK	Min	Max(5ns, 5nCK)	ns	1
Valid CS Requirement before CKE Input Low	tCSCKE	Min	1.75	ns	
Valid CS Requirement after CKE Input low	tCKELCS	Min	Max(5ns, 5nCK)	ns	
Valid Clock Requirement before CKE Input High	tCKCKEH	Min	Max(1.75ns, 3nCK)	ns	1
Exit power- down to next valid command delay	tXP	Min	Max(7.5ns, 5nCK)	ns	1
Valid CS Requirement before CKE Input High	tCSCKEH	Min	1.75	ns	
Valid CS Requirement after CKE Input High	tCKEHCS	Min	Max(7.5ns, 5nCK)	ns	
Valid Clock and CS Requirement after CKE Input low after MRW Command	tMRWCKEL	Min	Max(14ns, 10nCK)	ns	1
Valid Clock and CS Requirement after CKE Input low after ZQ Calibration Start Command	tZQCKE	Min	Max(1.75ns, 3nCK)	ns	1

**Notes:**

- Delay time has to satisfy both analog time(ns) and clock count(nCK).  
For example, tCMDCKE will not expire until CK has toggled through at least 3 full cycles (3 \*tCK) and 1.75ns has transpired. The case which 3nCK is applied to is shown below.

**Figure - tCMDCKE Timing**



### 3.40. Input clock stop and frequency change

LPDDR4 SDRAMs support input clock frequency change during CKE LOW under the following conditions:

- tCK(abs)min is met for each clock cycle;
- Refresh requirements apply during clock frequency change;
- During clock frequency change, only REFab or REFpb commands may be executing;
- Any Activate or Precharge commands have executed to completion prior to changing the frequency;

- The related timing conditions ( $t_{RCD}$ ,  $t_{RP}$ ) have been met prior to changing the frequency;
- The initial clock frequency shall be maintained for a minimum of 4 clock cycles after CKE goes LOW;
- The clock satisfies  $t_{CH}(abs)$  and  $t_{CL}(abs)$  for a minimum of 2 clock cycles prior to CKE going HIGH.

After the input clock frequency is changed and CKE is held HIGH, additional MRW commands may be required to set the WR, RL etc. These settings may need to be adjusted to meet minimum timing requirements at the target clock frequency.

LPDDR4 devices support clock stop during CKE LOW under the following conditions:

- CK\_t is held LOW and CK\_c is held HIGH or both are floated during clock stop;
- Refresh requirements apply during clock stop;
- During clock stop, only REFab or REFpb commands may be executing;
- Any Activate or Precharge commands have executed to completion prior to stopping the clock;
- The related timing conditions ( $t_{RCD}$ ,  $t_{RP}$ ) have been met prior to stopping the clock;
- The initial clock frequency shall be maintained for a minimum of 4 clock cycles after CKE goes LOW;
- The clock satisfies  $t_{CH}(abs)$  and  $t_{CL}(abs)$  for a minimum of 2 clock cycles prior to CKE going HIGH.

LPDDR4 devices support input clock frequency change during CKE HIGH under the following conditions:

- $t_{CK}(abs)_{min}$  is met for each clock cycle;
- Refresh requirements apply during clock frequency change;
- Any Activate, Read, Write, Precharge, Mode Register Write, or Mode Register Read commands must have executed to completion, including any associated data bursts prior to changing the frequency;
- The related timing conditions ( $t_{RCD}$ ,  $t_{WR}$ ,  $t_{WRA}$ ,  $t_{RP}$ ,  $t_{MRW}$ ,  $t_{MRR}$ , etc.) have been met prior to changing the frequency;
- CS shall be held LOW during clock frequency change;
- During clock frequency change, only REFab or REFpb commands may be executing;
- The LPDDR4 SDRAM is ready for normal operation after the clock satisfies  $t_{CH}(abs)$  and  $t_{CL}(abs)$  for a minimum of  $2 \cdot t_{CK} + t_{XP}$ .

After the input clock frequency is changed, additional MRW commands may be required to set the WR, RL etc. These settings may need to be adjusted to meet minimum timing requirements at the target clock frequency.

LPDDR4 devices support clock stop during CKE HIGH under the following conditions:

- CK\_t is held LOW and CK\_c is held HIGH during clock stop;
- CS shall be held LOW during clock stop;
- Refresh requirements apply during clock stop;
- During clock stop, only REFab or REFpb commands may be executing;
- Any Activate, Read, Write, Precharge, Mode Register Write, or Mode Register Read commands must have executed to completion, including any associated data bursts prior to stopping the clock;
- The related timing conditions ( $t_{RCD}$ ,  $t_{WR}$ ,  $t_{WRA}$ ,  $t_{RP}$ ,  $t_{MRW}$ ,  $t_{MRR}$ , etc.) have been met prior to stopping the clock;
- The LPDDR4 SDRAM is ready for normal operation after the clock is restarted and satisfies  $t_{CH}(abs)$  and  $t_{CL}(abs)$  for a minimum of  $2 \cdot t_{CK} + t_{XP}$ .

### 3.41. Truth Tables

Operation or timing that is not specified is illegal, and after such an event, in order to guarantee proper operation, the LPDDR4 device must be powered down and then restarted through the specified initialization sequence before normal operation can continue.

### 3.41.1. Command Truth Table

Command	SDR Command Pins	DDR CA Pins (10)						CK_t edge	Notes
	CS_n	CA0	CA1	CA2	CA3	CA4	CA5		
Deselect (DES)	L	X						R1	1,2
Multi Purpose Command (MPC)	H	L	L	L	L	L	OP6	R1	1,2,9
	L	OP0	OP1	OP2	OP3	OP4	OP5	R2	
Precharge (Per Bank, All Bank)	H	L	L	L	L	H	AB	R1	1,2,3,4
	L	BA0	BA1	BA2	V	V	V	R2	
Refresh (Per Bank, All Bank)	H	L	L	L	H	L	AB	R1	1,2,3,4
	L	BA0	BA1	BA2	V	V	V	R2	
Self Refresh Entry	H	L	L	L	H	H	V	R1	1,2
	L	V						R2	
Write-1	H	L	L	H	L	L	BL	R1	1,2,3,6,7,9
	L	BA0	BA1	BA2	V	C9	AP	R2	
Self Refresh Exit	H	L	L	H	L	H	V	R1	1,2
	L	V						R2	
Mask Write-1	H	L	L	H	H	L	L	R1	1,2,3,5,6,9
	L	BA0	BA1	BA2	V	C9	AP	R2	
RFU	H	L	L	H	H	H	V	R1	1,2
	L	V						R2	
Read-1	H	L	H	L	L	L	BL	R1	1,2,3,6,7,9
	L	BA0	BA1	BA2	V	C9	AP	R2	
CAS-2 (Write-2 or Mask Write-2 or Read-2 or MRR-2)	H	L	H	L	L	H	C8	R1	1,8,9
	L	C2	C3	C4	C5	C6	C7	R2	
RFU	H	L	H	L	H	L	V	R1	1,2
	L	V						R2	
RFU	H	L	H	L	H	H	V	R1	1,2
	L	V						R2	
MRW-1	H	L	H	H	L	L	OP7	R1	1,2,11
	L	MA0	MA1	MA2	MA3	MA4	MA5	R2	
MRW-2	H	L	H	H	L	H	OP6	R1	1,2,11
	L	OP0	OP1	OP2	OP3	OP4	OP5	R2	
MRR-1	H	L	H	H	H	L	V	R1	1,2,12
	L	MA0	MA1	MA2	MA3	MA4	MA5	R2	
RFU	H	L	H	H	H	H	V	R1	1,2
	L	V						R2	
Activate-1	H	H	L	R12	R13	R14	R15	R1	1,2,3,10
	L	BA0	BA1	BA2	V	R10	R11	R2	
Activate-2	H	H	H	R6	R7	R8	R9	R1	1,10
	L	R0	R1	R2	R3	R4	R5	R2	

#### Notes

1. All LPDDR4 commands except for Deselect are 2 clock cycle long and defined by states of CS and CA[5:0] at the first rising edge of clock. Deselect command is 1 clock cycle long.
2. "V" means "H" or "L" (a defined logic level). "X" means don't care in which case CS, CK\_t, CK\_c and CA[5:0] can be floated.
3. Bank addresses BA[2:0] determine which bank is to be operated upon.
4. AB "HIGH" during Precharge or Refresh command indicates that command must be applied to all banks and bank address is a don't care.
5. Mask Write-1 command supports only BL 16. For Mask Write-1 command, CA5 must be driven LOW on first rising clock cycle (R1).

6. AP "HIGH" during Write-1, Mask Write-1 or Read-1 commands indicates that an auto-precharge will occur to the bank associated with the Write, Mask Write or Read command.
7. If Burst Length on-the-fly is enabled, BL "HIGH" during Write-1 or Read-1 command indicates that Burst Length should be set on-the-fly to BL=32. BL "LOW" during Write-1 or Read-1 command indicates that Burst Length should be set on-the-fly to BL=16. If Burst Length on-the-fly is disabled, then BL must be driven to defined logic level "H" or "L".
8. For CAS-2 commands (Write-2 or Mask Write-2 or Read-2 or MRR-2 or MPC (Only Write FIFO, Read FIFO & Read DQ Calibration), C[1:0] are not transmitted on the CA[5:0] bus and are assumed to be zero. Note that for CAS-2 Write-2 or CAS-2 Mask Write-2 command, C[3:2] must be driven LOW.
9. Write-1 or Mask Write-1 or Read-1 or Mode Register Read-1 or MPC (Only Write FIFO, Read FIFO & Read DQ Calibration) command must be immediately followed by CAS-2 command consecutively without any other command in between. Write-1 or Mask Write-1 or Read-1 or Mode Register Read-1 or MPC (Only Write FIFO, Read FIFO & Read DQ Calibration) command must be issued first before issuing CAS-2 command. MPC (Only Start & Stop DQS Oscillator, Start & Latch ZQ Calibration) commands do not require CAS-2 command; they require two additional DES or NOP commands consecutively before issuing any other commands.
10. Activate-1 command must be immediately followed by Activate-2 command consecutively without any other command in between. Activate-1 command must be issued first before issuing Activate-2 command. Once Activate-1 command is issued, Activate-2 command must be issued before issuing another Activate-1 command.
11. MRW-1 command must be immediately followed by MRW-2 command consecutively without any other command in between. MRW-1 command must be issued first before issuing MRW-2 command.
12. MRR-1 command must be immediately followed by CAS-2 command consecutively without any other command in between. MRR-1 command must be issued first before issuing CAS-2 command.

### 3.42. Post Package Repair - PPR

LPDDR4 supports Fail Row address repair as an optional feature and it is readable through MR25 OP[7:0]. PPR provides simple and easy repair method in the system and Fail Row address can be repaired by the electrical programming of Electrical-fuse scheme.

With PPR, LPDDR4 can correct 1Row per Bank.

Electrical-fuse cannot be switched back to un-fused states once it is programmed. The controller should prevent unintended the PPR mode entry and repair.

#### 3.42.1. Fail Row Address Repair

The following is procedure of PPR.

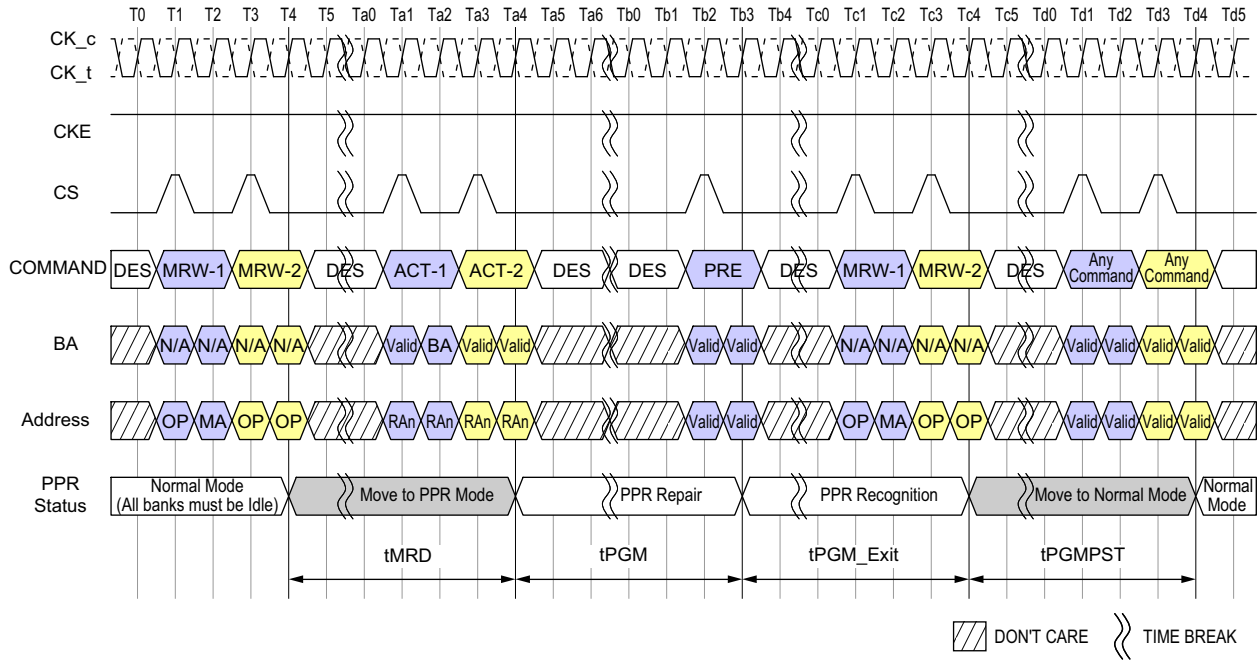
1. Before entering 'PPR' mode, All banks must be Precharged
2. Enable PPR using MR4 bit "OP4=1" and wait tMRD
3. Issue ACT command with Fail Row address
4. Wait tPGM to allow DRAM repair target Row Address internally and issue PRE
5. Wait tPGM\_Exit after PRE which allow DRAM to recognize repaired Row address
6. Exit PPR with setting MR4 bit "OP4=0"
7. LPDDR4 will accept any valid command after tPGMPST
8. In More than one fail address repair case, Repeat Step 2 to 7

Once PPR mode is exited, to confirm if target row is repaired correctly, host can verify by writing data into the target row and reading it back after PPR exit with MR4 [OP4=0] and tPGMPST.

The following Timing diagram show PPR related MR bits and its operation.



**Figure - PPR Timing**



### 4. Absolute Maximum DC Ratings

Stresses greater than those listed may cause permanent damage to the device. This is a stress rating only, and functional operation of the device at these or any other conditions above those indicated in the operational sections of this specification is not implied. Exposure to absolute maximum rating conditions for extended periods may affect reliability.

Parameter	Symbol	Min	Max	Unit	Notes
VDD1 supply voltage relative to VSS	VDD1	-0.4	2.1	V	1
VDD2 supply voltage relative to VSS	VDD2	-0.4	1.5	V	1
VDDQ supply voltage relative to VSSQ	VDDQ	-0.4	1.5	V	1
Voltage on Any Pin relative to VSS	VIN, VOUT	-0.4	1.5	V	
Storage Temperature	TSTG	-55	125	°C	2

Notes:

1. See the section "Power-up, Initialization, and Power-off" for information about relationships between power supplies.
2. Storage Temperature is the case surface temperature on the center/top side of the device. For the measurement conditions, please refer to JE5D51-2 standard.

### 5. AC and DC Operating Conditions

#### 5.1. Recommended DC Operating Conditions

Parameter	Symbol	Min	Typ	Max	Unit	Notes
Core Power 1	VDD1	1.70	1.80	1.95	V	1,2
Core Power 2 & CA Power	VDD2	1.06	1.10	1.17	V	1,2,3
I/O Buffer Power	VDDQ	0.57	0.60	0.65	V	2,3

- VDD1 uses significantly less current than VDD2.
- The voltage range is for DC voltage only. DC is defined as the voltage supplied at the DRAM and is inclusive of all noise up to 20MHz at the DRAM package ball.
- The voltage noise tolerance from DC to 20MHz exceeding a pk-pk tolerance of 45mV at the DRAM ball is not included in the TdIVW.

#### 5.2. Input Leakage Current

Parameter	Symbol	Min	Max	Unit	Notes
Input Leakage current	$I_L$	-4	4	uA	1,2

Notes:

- For CK\_t, CK\_c, CKE, CS, CA, ODT\_CA and RESET\_n. Any input  $0V \leq V_{IN} \leq VDD2$  (All other pins not under test = 0V).
- CA ODT is disabled for CK\_t, CK\_c, CS, and CA.

#### 5.3. Input/Output Leakage Current

Parameter	Symbol	Min	Max	Unit	Notes
Input/Output Leakage current	$I_{OZ}$	-5	5	uA	1,2

Notes:

- For DQ, DQS\_t, DQS\_c and DMI. Any I/O  $0V \leq V_{OUT} \leq VDDQ$ .
- I/Os status are disabled: High Impedance and ODT Off.

#### 5.4. Operating Temperature

Parameter	Symbol	Min	Max	Unit	Note
Operating Temperature	Standard	-25	85	°C	1
	Extended	85	105		1

- Operating Temperature is the case surface temperature on the center-top side of the LPDDR4 device. For the measurement conditions, please refer to JESD51-2 standard.
- Some applications require operation of LPDDR4 in the maximum temperature conditions in the Elevated Temperature Range between 85°C and 105°C case temperature. For LPDDR4 devices, derating may be necessary to operate in this range. See MR4 on the section "Mode Register".
- Either the device case temperature rating or the temperature sensor (See the section of "Temperature Sensor") may be used to set an appropriate refresh rate, determine the need for AC timing de-rating and/or monitor the operating temperature. When using the temperature sensor, the actual device case temperature may be higher than the TOPER rating that applies for the Standard or Elevated Temperature Ranges. For example, TCASE may be above 85°C when the temperature sensor indicates a temperature of less than 85°C.

### 6. AC and DC Input Measurement Levels

#### 6.1. 1.1V High speed LVCMOS (HS\_LLVC MOS)

##### 6.1.1. Standard specifications

All voltages are referenced to ground except where noted.

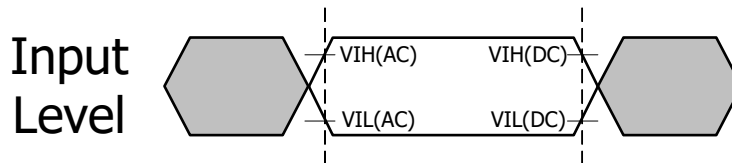
**Table - LPDDR4 Input level for CKE**

Parameter	Symbol	Min	Max	Unit	Notes
Input high level (AC)	VIH(AC)	0.75*VDD2	VDD2+0.2	V	1
Input low level (AC)	VIL(AC)	-0.2	0.25*VDD2	V	1
Input high level (DC)	VIH(DC)	0.65*VDD2	VDD2+0.2	V	
Input low level (DC)	VIL(DC)	-0.2	0.35*VDD2	V	

Notes:


1. Refer to LPDDR4 AC Over/Undershoot section.

**Figure - Input AC timing definition for CKE**



Note:

1. AC level is guaranteed transition point
2. DC level is hysteresis

 Don't Care

##### 6.1.2. LPDDR4 Input Level for Reset\_n and ODT\_CA

This definition applies to Reset\_n and ODT\_CA.

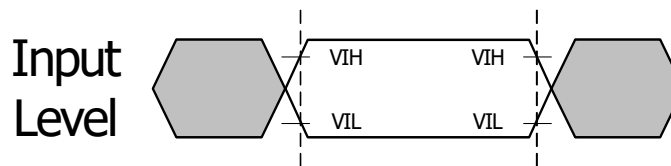
**Table - LPDDR4 Input level for Reset\_n and ODT\_CA**

Parameter	Symbol	Min	Max	Unit	Notes
Input high level	VIH	0.8*VDD2	VDD2+0.2	V	1
Input low level	VIL	-0.2	0.20*VDD2	V	1

Notes:

1. Refer to LPDDR4 AC Over/Undershoot section.

**Figure - Input AC timing definition**



 Don't Care

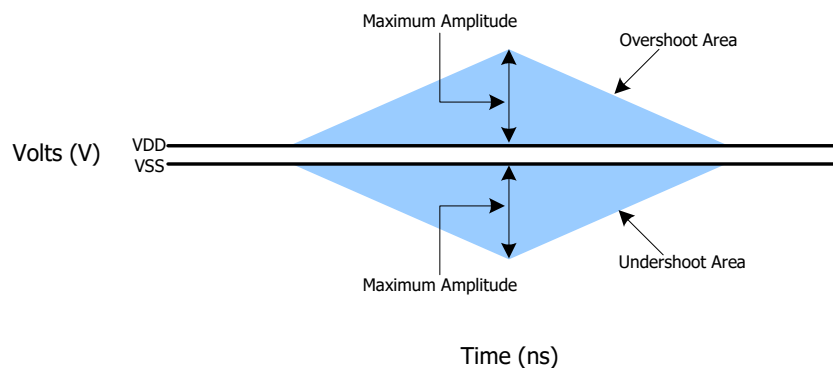
### 6.1.3. AC Over/Undershoot

#### 6.1.3.1. LPDDR4 AC Over/Undershoot

**Table - LPDDR4 AC Over/Undershoot**

Parameter	Specification	Units
Maximum peak amplitude allowed for overshoot area	0.35	V
Maximum peak amplitude allowed for undershoot area	0.35	V
Maximum overshoot area above VDD/VDDQ	0.8	V-ns
Maximum undershoot area below VSS/VSSQ	0.8	V-ns

**Figure - AC Overshoot and Undershoot Definition for Address and Control Pins**

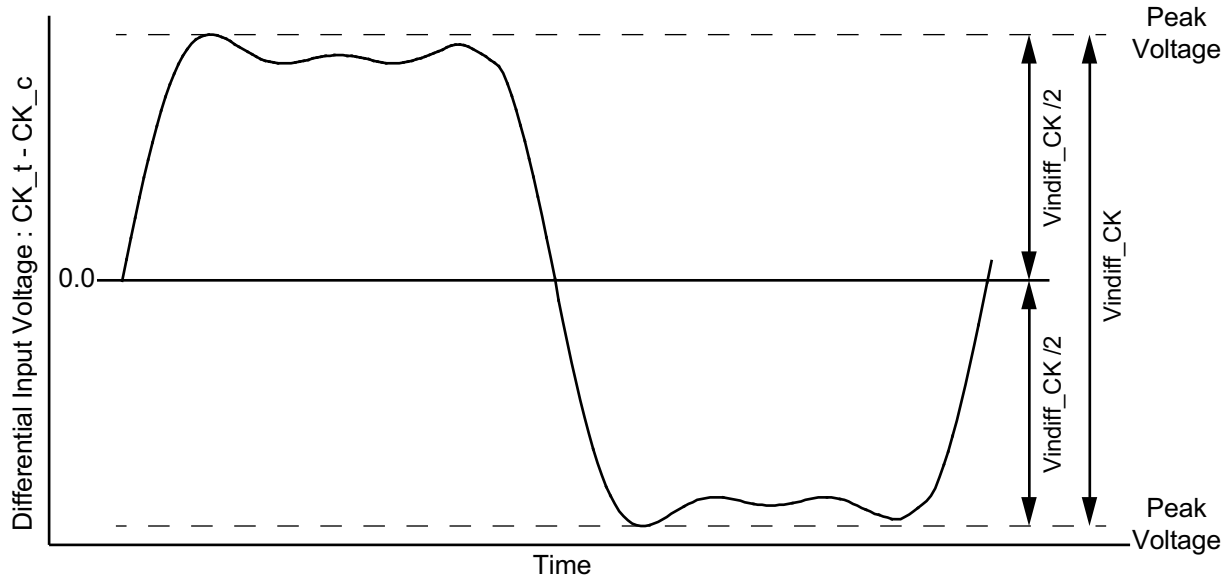


## 6.2. Differential Input Voltage

### 6.2.1. Differential Input Voltage for CK

The minimum input voltage need to satisfy both  $V_{indiff\_CK}$  and  $V_{indiff\_CK} / 2$  specification at input receiver and their measurement period is  $1t_{CK}$ .  $V_{indiff\_CK}$  is the peak to peak voltage centered on 0 volts differential and  $V_{indiff\_CK} / 2$  is max and min peak voltage from 0V.

**Figure - CK Differential Input Voltage**



**Table - CK differential input voltage**

Parameter	Symbol	Data Rate						Unit	Notes
		1600/1867 <sup>a</sup>		2133/2400/3200		4266			
		Min	Max	Min	Max	Min	Max		
CK differential input voltage	Vindiff_CK	420	-	380	-	360	-	mV	1

Notes:

- The peak voltage of Differential CK signals is calculated in a following equation.

$$Vindiff\_CK = (\text{Max Peak Voltage}) - (\text{Min Peak Voltage})$$

$$\text{Max Peak Voltage} = \text{Max}(f(t))$$

$$\text{Min Peak Voltage} = \text{Min}(f(t))$$

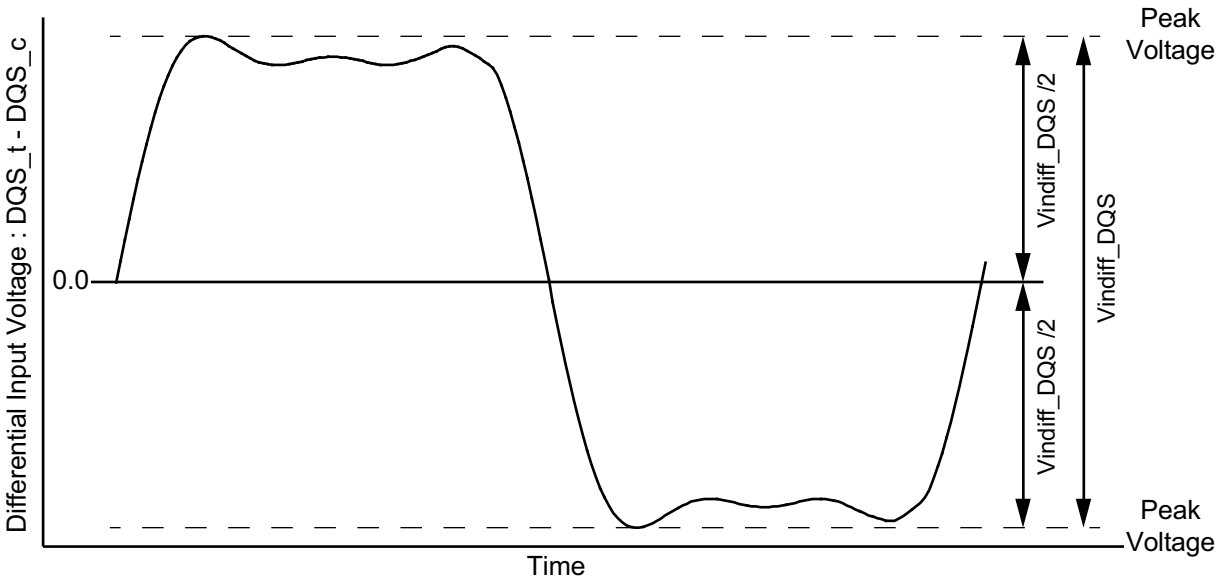
$$f(t) = VCK\_t - VCK\_c$$

- The following requirements apply for DQ operating frequencies at or below 1333Gbps for all speed bins for the first column 1600/1867.

### 6.2.2. Differential Input Voltage for DQS

The minimum input voltage need to satisfy both  $V_{indiff\_DQS}$  and  $V_{indiff\_DQS}/2$  specification at input receiver and their measurement period is  $1UI(t_{CK}/2)$ .  $V_{indiff\_DQS}$  is the peak to peak voltage centered on 0 volts differential and  $V_{indiff\_DQS}/2$  is max and min peak voltage from 0V.

**Figure - DQS Differential Input Voltage**



**Table - CK differential input voltage**

Parameter	Symbol	Data Rate						Unit	Notes
		1600/1867 <sup>a</sup>		2133/2400/3200		4266			
		Min	Max	Min	Max	Min	Max		
DQS differential input	$V_{indiff\_DQS}$	360	-	360	-	340	-	mV	1

Notes:

- The peak voltage of Differential CK signals is calculated in a following equation.

$$V_{indiff\_DQS} = (\text{Max Peak Voltage}) - (\text{Min Peak Voltage})$$

$$\text{Max Peak Voltage} = \text{Max}(f(t))$$

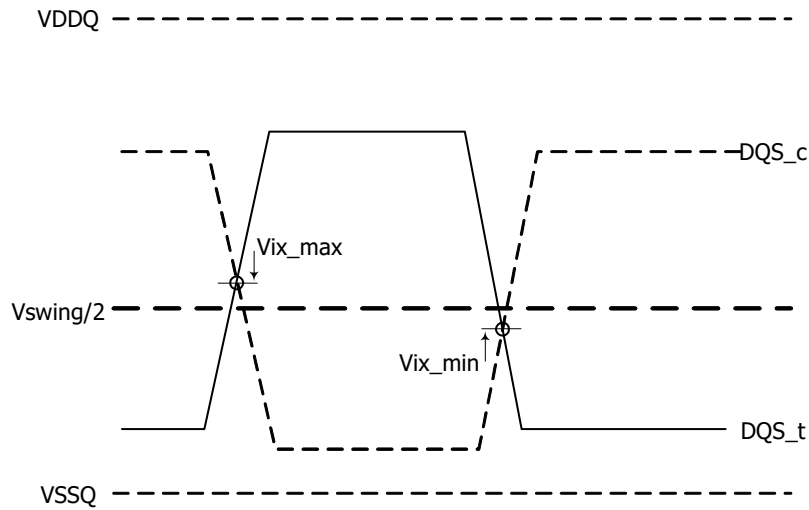
$$\text{Min Peak Voltage} = \text{Min}(f(t))$$

$$f(t) = VDQS_t - VDQS_c$$

- The following requirements apply for DQ operating frequencies at or below 1333Gbps for all speed bins for the first column 1600/1867.

### 6.3. Differential Input Cross Point Voltage

**Figure - DQS input crosspoint voltage (Vix)**



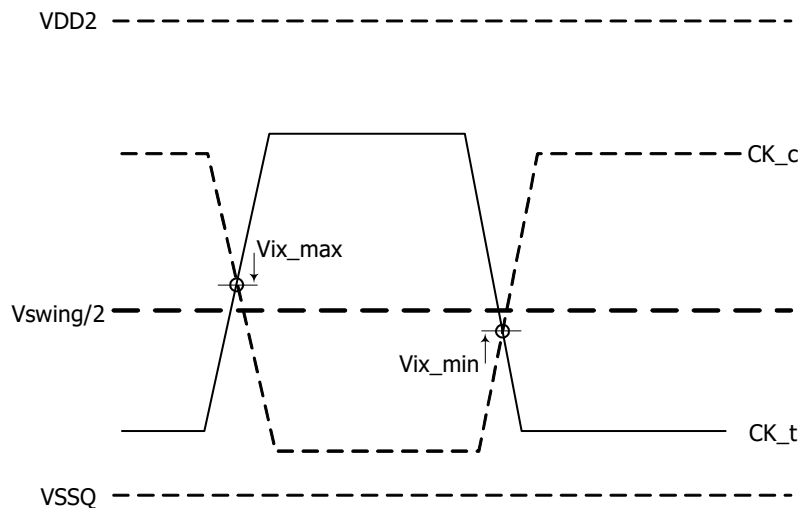
**Table - DQS input voltage crosspoint (Vix) ratio**

Parameter	Symbol	min/max	LPDDR4 2133	LPDDR4 3200	LPDDR4 4200	Units	Notes
DQS Differential input crosspoint voltage ratio	Vix_DQS_ratio	max	20	20	20	%	1,2

Notes:

1. The Vix voltage is referenced to  $V_{swing}/2(avg) = 0.5(V_{DQS\_t} + V_{DQS\_c})$  where the average is over tbd UI.
2. The ratio of the Vix pk voltage divided by  $V_{diff\_DQS}$  :  $Vix\_DQS\_Ratio = 100 * (Vix\_DQS / V_{diff\_DQS})$  where  $V_{diff\_DQS} = 2 * |V_{DQS\_t} - V_{DQS\_c}|$

**Figure - CK input crosspoint voltage (Vix)**





**Table - CK input voltage crosspoint (Vix) ratio**

Parameter	Symbol	min/max	LPDDR4	LPDDR4	LPDDR4	Units	Notes
			2133	3200	4200		
CK Differential input crosspoint voltage ratio	Vix_CK_ratio	max	25	25	25	%	1,2

Notes:

1. The Vix voltage is referenced to  $V_{swing}/2(avg) = 0.5(V_{CK\_t} + V_{CK\_c})$  where the average is over tbd UI.
2. The ratio of the Vix pk voltage divided by  $V_{diff\_CK}$  :  $V_{ix\_CK\_Ratio} = 100 * (V_{ix\_CK}/V_{diff\_CK})$  where  $V_{diff\_CK} = 2 * |V_{CK\_t} - V_{CK\_c}|$

### 6.4. AC and DC Logic Input Levels for ODT input

**Table - LPDDR4 Input level**

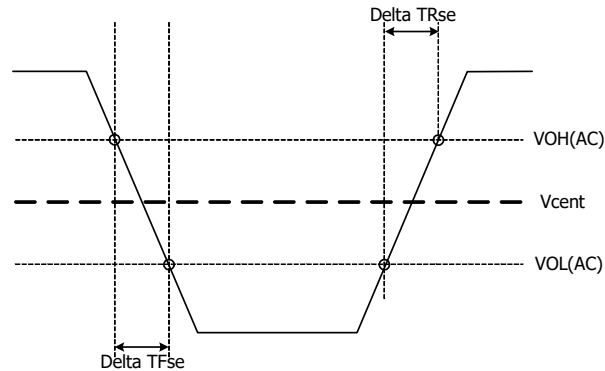
Parameter	Symbol	Min	Max	Unit	Notes
Input high level (AC)	VIH(AC)	$0.75 * V_{DD2}$	$V_{DD2} + 0.2$	V	1
Input low level (AC)	VIL(AC)	-0.2	$0.25 * V_{DD2}$	V	1
Input high level (DC)	VIH(DC)	$0.65 * V_{DD2}$	$V_{DD2} + 0.2$	V	
Input low level (DC)	VIL(DC)	-0.2	$0.35 * V_{DD2}$	V	

Notes:

1. Refer to LPDDR4 AC Over/Undershoot section.

### 6.5. Single Ended Output Slew Rate

**Figure - Single Ended Output Slew Rate Definition**



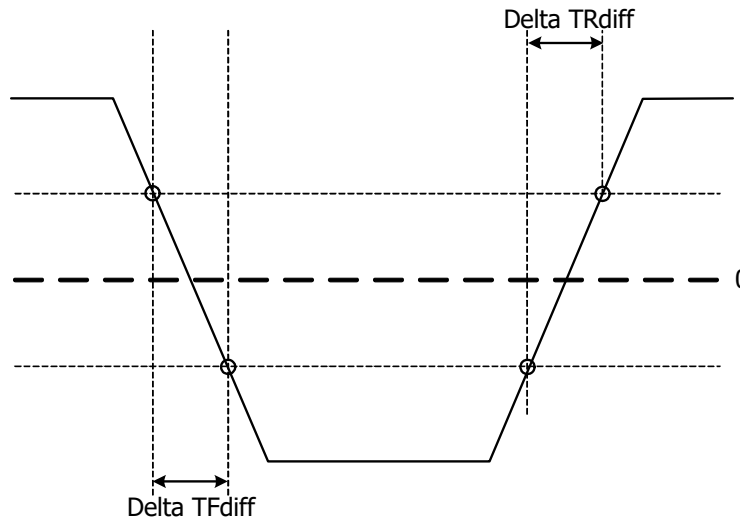
**Table - Output Slew Rate (Single-ended)**

Parameter	Symbol	Value		Units
		Min (Note 1)	Max (Note 2)	
Single-ended Output Slew Rate (VOH = VDDQ*0.5)	SRQse	3.5	9.0	V/ns
Output slew-rate matching ratio (Rise to Fall)		0.8	1.2	

Parameter	Symbol	Value		Units
		Min (Note 1)	Max (Note 2)	
Description: SR: Slew Rate Q: Query Output (like in DQ, which stands for Data-in, Query-Output) se: Single-ended Signals  Notes: 1 Measured with output reference load. 2 The ratio of pull-up to pull-down slew rate is specified for the same temperature and voltage, over the entire temperature and voltage range. For a given output, it represents the maximum difference between pull-up and pull-down drivers due to process variation. 3 The output slew rate for falling and rising edges is defined and measured between $VOL(AC)=0.2*VOH(DC)$ and $VOH(AC)=0.8*VOH(DC)$ . 4 Slew rates are measured under average SSO conditions, with 50% of DQ signals per data byte switching.				

### 6.6. Differential Output Slew Rate

**Figure - Differential Output Slew Rate Definition**



**Table - Differential Output Slew Rate**

Parameter	Symbol	Value		Units
		Min (Note 1)	Max (Note 2)	
Single-ended Output Slew Rate ( $VOH = VDDQ*0.5$ )	SRQdiff	7	18	V/ns
Description: SR: Slew Rate Q: Query Output (like in DQ, which stands for Data-in, Query-Output) diff: Differential Signals  Notes: 1 Measured with output reference load. 2 The output slew rate for falling and rising edges is defined and measured between $VOL(AC)=0.2*VOH(DC)$ and $VOH(AC)=0.8*VOH(DC)$ . 3 Slew rates are measured under average SSO conditions, with 50% of DQ signals per data byte switching.				

### 6.7. Overshoot and Undershoot Specification for LVSTL

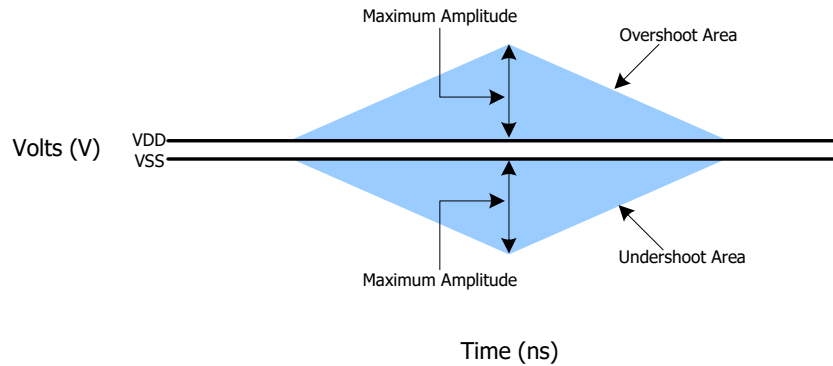
**Table - AC Overshoot / Undershoot Specification**

Parameter	1600 to 3200	4266	Units
Maximum peak amplitude allowed for overshoot area	0.3V	TBD	V
Maximum peak amplitude allowed for undershoot area	0.3V	TBD	V
Maximum overshoot area above VDD/VDDQ	0.1V-ns	TBD	V-ns
Maximum undershoot area below VSS/VSSQ	0.1V-ns	TBD	V-ns

Notes:

1. VDD stands for VDD2 for CA[5:0], CK\_t, CK\_c, CS\_n, CKE and ODT. VDD stands for VDDQ for DQ, DMI, DQS\_t and DQS\_c.
2. VSS stands for VSS for CA[5:0], CK\_t, CK\_c, CS\_n, CKE and ODT. VSS stands for VSSQ for DQ, DMI, DQS\_t and DQS\_c.
3. Maximum peak amplitude values are referenced from actual VDD and VSS values.
4. Maximum area values are referenced from maximum operating VDD and VSS values.

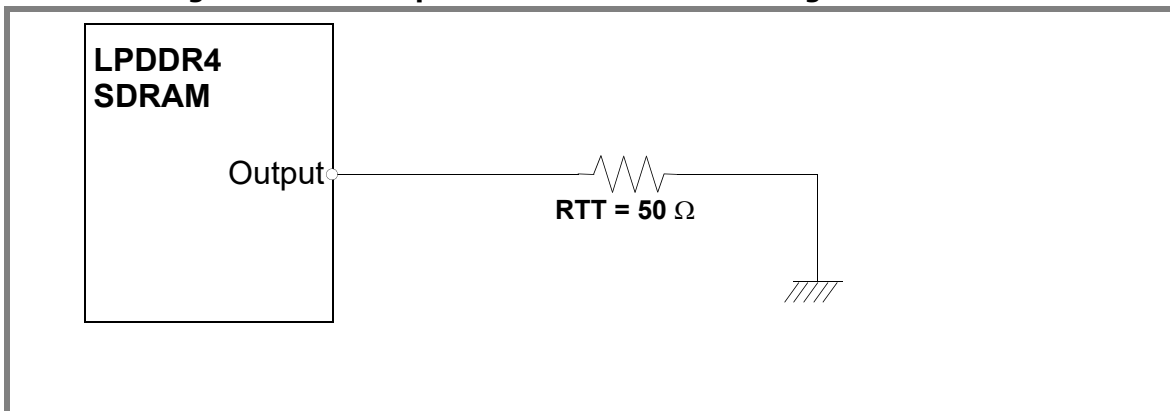
**Figure - AC Overshoot and Undershoot Definition**



### 6.8. LVSTL Driver Output Timing Reference Load

These 'Timing Reference Loads' are not intended as a precise representation of any particular system environment or a depiction of the actual load presented by a production tester. System designers should use IBIS or other simulation tools to correlate the timing reference load to a system environment. Manufacturers correlate to their production test conditions, generally one or more coaxial transmission lines terminated at the tester electronics.

**Figure - Driver Output Reference Load for Timing and Slew Rate**

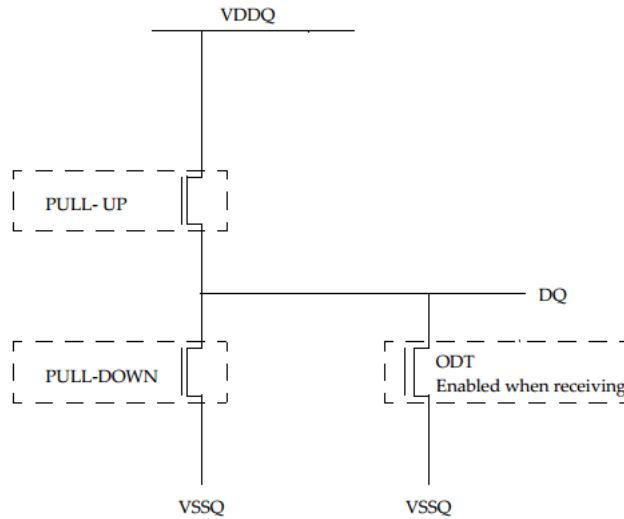


Note: 1. All output timing parameter values (like  $t_{DQSQ}$ ,  $t_{DQSQ}$ ,  $t_{QHS}$ ,  $t_{HZ}$ ,  $t_{RPRE}$  etc.) are reported with respect to this reference load. This reference load is also used to report slew rate.

### 6.9. LVSTL (Low Voltage Swing Terminated Logic) IO System

LVSTL I/O cell is comprised of pull-up, pull-down driver and a terminator. The basic cell is shown in figure below.

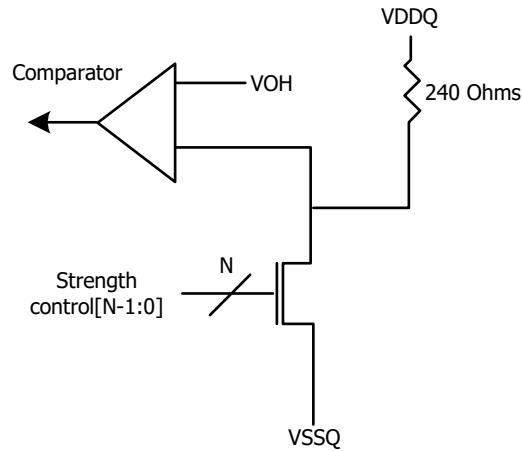
**Figure - LVSTL I/O Cell**



To ensure that the target impedance is achieved the LVSTL I/O cell is designed to be calibrated as follows:

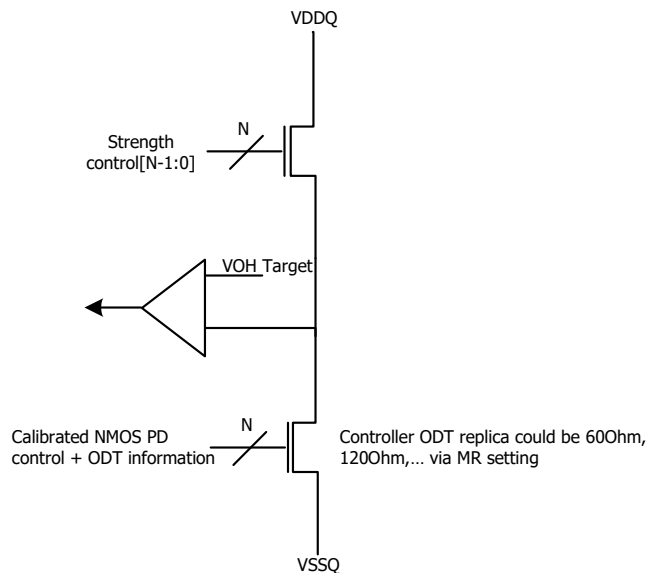
- 1) First calibrate the pull-down device against a 240 Ohm resistor to VDDQ via the ZQ pin.
  - Set Strength Control to minimum setting
  - Increase drive strength until comparator detects data bit is less than VOH.
  - NMOS pull-down device is calibrated to 240 Ohms

**Figure - Pull-down calibration**



- 2) Then calibrate the pull-up device against the calibrated pull-down device.
- Set VOH target and NMOS controller ODT replica via MRS (VOH can be automatically controlled by ODT MRS)
  - Set Strength Control to minimum setting
  - Increase drive strength until comparator detects data bit is greater than VOH target
  - NMOS pull-up device is now calibrated to VOH target

**Figure - Pull-up calibration**



### 7. Input/Output Capacitance

**Table - Input/Output Capacitance**

Parameter	Symbol	Min/Max	3733-533	4266	Unit	Note
Input capacitance, CK_t and CK_c	CCK	Min	0.5	TBD	pF	1,2
		Max	0.9	TBD		
Input capacitance delta, CK_t and CK_c	CDCK	Min	0.0	TBD	pF	1,2,3
		Max	0.09	TBD		
Input capacitance, all other input-only pins	CI	Min	0.5	TBD	pF	1,2,4
		Max	0.9	TBD		
Input capacitance delta, all other input-only pins	CDI	Min	-0.1	TBD	pF	1,2,5
		Max	0.1	TBD		
Input/output capacitance, DQ, DMI, DQS_t, DQS_c	CIO	Min	0.7	TBD	pF	1,2,6
		Max	1.3	TBD		
Input/output capacitance delta, DQS_t and DQS_c	CDDQS	Min	0.0	TBD	pF	1,2,7
		Max	0.1	TBD		
Input/output capacitance delta, DQ and DM	CDIO	Min	-0.1	TBD	pF	1,2,8
		Max	0.1	TBD		
Input/Output Capacitance ZQ	CZQ	Min	0.0	TBD	pF	1,2
		Max	5.0	TBD		

**Notes**

1. This parameter applies to die device only (does not include package capacitance).
2. This parameter is not subject to production test. It is verified by design and characterization. The capacitance is measured according to JEP147 (Procedure for measuring input capacitance using a vector network analyzer (VNA) with VDD1, VDD2, VDDQ, VSS, VSSQ applied and all other pins floating).
3. Absolute value of CCK\_t . CCK\_c.
4. CI applies to CS\_n, CKE, CA0~CA5.
5.  $CDI = CI \cdot 0.5 \cdot (CCK\_t + CCK\_c)$
6. DMI loading matches DQ and DQS.
7. Absolute value of CDQS\_t and CDQS\_c.
8.  $CDIO = CIO \cdot 0.5 \cdot (CDQS\_t + CDQS\_c)$  in byte-lane.

### 8. IDD Specification Parameters and Test Conditions

#### 8.1. IDD Measurement Conditions

The following definitions are used within the IDD measurement tables unless stated otherwise:

LOW:  $V_{IN} \leq V_{IL}(DC) \text{ MAX}$

HIGH:  $V_{IN} \geq V_{IH}(DC) \text{ MIN}$

STABLE: Inputs are stable at a HIGH or LOW level

SWITCHING: See following tables for switching definition of signals.

**Table - Definition of switching for CA input signals**

Switching for CA								
CK_t edge	R1	R2	R3	R4	R5	R6	R7	R8
CKE	HIGH	HIGH	HIGH	HIGH	HIGH	HIGH	HIGH	HIGH
CS	LOW	LOW	LOW	LOW	LOW	LOW	LOW	LOW
CA0	HIGH	LOW	LOW	LOW	LOW	HIGH	HIGH	HIGH
CA1	HIGH	HIGH	HIGH	LOW	LOW	LOW	LOW	HIGH
CA2	HIGH	LOW	LOW	LOW	LOW	HIGH	HIGH	HIGH
CA3	HIGH	HIGH	HIGH	LOW	LOW	LOW	LOW	HIGH
CA4	HIGH	LOW	LOW	LOW	LOW	HIGH	HIGH	HIGH
CA5	HIGH	HIGH	HIGH	LOW	LOW	LOW	LOW	HIGH

Notes:

1. CS must always be driven LOW.
2. 50% of CA bus is changing between HIGH and LOW once per clock for the CA bus.
3. The above pattern is used continuously during IDD measurement for IDD values that require switching on the CA bus.

**Table - CA pattern for IDD4R**

Clock Cycle Number	CKE	CS	Command	CA0	CA1	CA2	CA3	CA4	CA5
N	HIGH	HIGH	Read-1	L	H	L	L	L	L
N+1	HIGH	LOW		L	H	L	L	L	L
N+2	HIGH	HIGH	CAS-2	L	H	L	L	H	L
N+3	HIGH	LOW		L	L	L	L	L	L
N+4	HIGH	LOW	Deselect	L	L	L	L	L	L
N+5	HIGH	LOW	Deselect	L	L	L	L	L	L
N+6	HIGH	LOW	Deselect	L	L	L	L	L	L
N+7	HIGH	LOW	Deselect	L	L	L	L	L	L
N+8	HIGH	HIGH	Read-1	L	H	L	L	L	L
N+9	HIGH	LOW		L	H	L	L	H	L
N+10	HIGH	HIGH	CAS-2	L	H	L	L	H	H
N+11	HIGH	LOW		H	H	H	H	H	H
N+12	HIGH	LOW	Deselect	L	L	L	L	L	L
N+13	HIGH	LOW	Deselect	L	L	L	L	L	L
N+14	HIGH	LOW	Deselect	L	L	L	L	L	L
N+15	HIGH	LOW	Deselect	L	L	L	L	L	L

Notes:

1. BA[2:0] = 010, CA[9:4] = 000000 or 111111, Burst Order CA[3:2] = 00 or 11 (Same as LPDDR3 IDD4R Spec)
2. Difference from LPDDR3 Spec : CA pins are kept low with DES CMD to reduce ODT current.

**Table - CA pattern for IDD4W**

Clock Cycle Number	CKE	CS	Command	CA0	CA1	CA2	CA3	CA4	CA5
N	HIGH	HIGH	Write-1	L	L	H	L	L	L
N+1	HIGH	LOW		L	H	L	L	L	L
N+2	HIGH	HIGH	CAS-2	L	H	L	L	H	L
N+3	HIGH	LOW		L	L	L	L	L	L
N+4	HIGH	LOW	Deselect	L	L	L	L	L	L
N+5	HIGH	LOW	Deselect	L	L	L	L	L	L
N+6	HIGH	LOW	Deselect	L	L	L	L	L	L
N+7	HIGH	LOW	Deselect	L	L	L	L	L	L
N+8	HIGH	HIGH	Write-1	L	L	H	L	L	L
N+9	HIGH	LOW		L	H	L	L	H	L
N+10	HIGH	HIGH	CAS-2	L	H	L	L	H	H
N+11	HIGH	LOW		L	L	H	H	H	H
N+12	HIGH	LOW	Deselect	L	L	L	L	L	L
N+13	HIGH	LOW	Deselect	L	L	L	L	L	L
N+14	HIGH	LOW	Deselect	L	L	L	L	L	L
N+15	HIGH	LOW	Deselect	L	L	L	L	L	L

Notes:

1. BA[2:0] = 010, CA[9:4] = 000000 or 111111 (Same as LPDDR3 IDD4W Spec.)
2. Difference from LPDDR3 Spec:
  - 1-No burst ordering
  - 2-CA pins are kept low with DES CMD to reduce ODT current.

**Table - Data Pattern for IDD4W (DBI off)**

DBI OFF case										No. of 1's
	DQ[7]	DQ[6]	DQ[5]	DQ[4]	DQ[3]	DQ[2]	DQ[1]	DQ[0]	DBI	
BL0	1	1	1	1	1	1	1	1	0	8
BL1	1	1	1	1	0	0	0	0	0	4
BL2	0	0	0	0	0	0	0	0	0	0
BL3	0	0	0	0	1	1	1	1	0	4
BL4	0	0	0	0	0	0	1	1	0	2
BL5	0	0	0	0	1	1	1	1	0	4
BL6	1	1	1	1	1	1	0	0	0	6
BL7	1	1	1	1	0	0	0	0	0	4
BL8	1	1	1	1	1	1	1	1	0	8
BL9	1	1	1	1	0	0	0	0	0	4
BL10	0	0	0	0	0	0	0	0	0	0
BL11	0	0	0	0	1	1	1	1	0	4
BL12	0	0	0	0	0	0	1	1	0	2
BL13	0	0	0	0	1	1	1	1	0	4
BL14	1	1	1	1	1	1	0	0	0	6
BL15	1	1	1	1	0	0	0	0	0	4
BL16	1	1	1	1	1	1	0	0	0	6
BL17	1	1	1	1	0	0	0	0	0	4
BL18	0	0	0	0	0	0	1	1	0	2



DBI OFF case										No. of 1's
	DQ[7]	DQ[6]	DQ[5]	DQ[4]	DQ[3]	DQ[2]	DQ[1]	DQ[0]	DBI	
BL19	0	0	0	0	1	1	1	1	0	4
BL20	0	0	0	0	0	0	0	0	0	0
BL21	0	0	0	0	1	1	1	1	0	4
BL22	1	1	1	1	1	1	1	1	0	8
BL23	1	1	1	1	0	0	0	0	0	4
BL24	0	0	0	0	0	0	1	1	0	2
BL25	0	0	0	0	1	1	1	1	0	4
BL26	1	1	1	1	1	1	0	0	0	6
BL27	1	1	1	1	0	0	0	0	0	4
BL28	1	1	1	1	1	1	1	1	0	8
BL29	1	1	1	1	0	0	0	0	0	4
BL30	0	0	0	0	0	0	0	0	0	0
BL31	0	0	0	0	1	1	1	1	0	4
No. of 1's	16	16	16	16	16	16	16	16		

Notes:

1. Simplified pattern compared with last showing.
2. Same data pattern was applied to DQ[4], DQ[5], DQ[6], DQ[7] for reducing complexity for IDD4W/R pattern programming.

**Table - Data Pattern for IDD4R (DBI off)**

DBI OFF case										No. of 1's
	DQ[7]	DQ[6]	DQ[5]	DQ[4]	DQ[3]	DQ[2]	DQ[1]	DQ[0]	DBI	
BL0	1	1	1	1	1	1	1	1	0	8
BL1	1	1	1	1	0	0	0	0	0	4
BL2	0	0	0	0	0	0	0	0	0	0
BL3	0	0	0	0	1	1	1	1	0	4
BL4	0	0	0	0	0	0	1	1	0	2
BL5	0	0	0	0	1	1	1	1	0	4
BL6	1	1	1	1	1	1	0	0	0	6
BL7	1	1	1	1	0	0	0	0	0	4
BL8	1	1	1	1	1	1	1	1	0	8
BL9	1	1	1	1	0	0	0	0	0	4
BL10	0	0	0	0	0	0	0	0	0	0
BL11	0	0	0	0	1	1	1	1	0	4
BL12	0	0	0	0	0	0	1	1	0	2
BL13	0	0	0	0	1	1	1	1	0	4
BL14	1	1	1	1	1	1	0	0	0	6
BL15	1	1	1	1	0	0	0	0	0	4
BL16	1	1	1	1	1	1	1	1	0	8
BL17	1	1	1	1	0	0	0	0	0	4
BL18	0	0	0	0	0	0	0	0	0	0
BL19	0	0	0	0	1	1	1	1	0	4
BL20	1	1	1	1	1	1	0	0	0	6
BL21	1	1	1	1	0	0	0	0	0	4

DBI OFF case										No. of 1's
	DQ[7]	DQ[6]	DQ[5]	DQ[4]	DQ[3]	DQ[2]	DQ[1]	DQ[0]	DBI	
BL22	0	0	0	0	0	0	1	1	0	2
BL23	0	0	0	0	1	1	1	1	0	4
BL24	0	0	0	0	0	0	0	0	0	0
BL25	0	0	0	0	1	1	1	1	0	4
BL26	1	1	1	1	1	1	1	1	0	8
BL27	1	1	1	1	0	0	0	0	0	4
BL28	0	0	0	0	0	0	1	1	0	2
BL29	0	0	0	0	1	1	1	1	0	4
BL30	1	1	1	1	1	1	0	0	0	6
BL31	1	1	1	1	0	0	0	0	0	4
No. of 1's	16	16	16	16	16	16	16	16		

Notes:

1. Same data pattern was applied to DQ[4], DQ[5], DQ[6], DQ[7] for reducing complexity for IDD4W/R pattern programming.

**Table - Data Pattern for IDD4W (DBI on)**

DBI ON case										No. of 1's
	DQ[7]	DQ[6]	DQ[5]	DQ[4]	DQ[3]	DQ[2]	DQ[1]	DQ[0]	DBI	
BL0	0	0	0	0	0	0	0	0	1	1
BL1	1	1	1	1	0	0	0	0	0	4
BL2	0	0	0	0	0	0	0	0	0	0
BL3	0	0	0	0	1	1	1	1	0	4
BL4	0	0	0	0	0	0	1	1	0	2
BL5	0	0	0	0	1	1	1	1	0	4
BL6	0	0	0	0	0	0	1	1	1	3
BL7	1	1	1	1	0	0	0	0	0	4
BL8	0	0	0	0	0	0	0	0	1	1
BL9	1	1	1	1	0	0	0	0	0	4
BL10	0	0	0	0	0	0	0	0	0	0
BL11	0	0	0	0	1	1	1	1	0	4
BL12	0	0	0	0	0	0	1	1	0	2
BL13	0	0	0	0	1	1	1	1	0	4
BL14	0	0	0	0	0	0	1	1	1	3
BL15	1	1	1	1	0	0	0	0	0	4
BL16	0	0	0	0	0	0	1	1	1	3
BL17	1	1	1	1	0	0	0	0	0	4
BL18	0	0	0	0	0	0	1	1	0	2
BL19	0	0	0	0	1	1	1	1	0	4
BL20	0	0	0	0	0	0	0	0	0	0
BL21	0	0	0	0	1	1	1	1	0	4
BL22	0	0	0	0	0	0	0	0	1	1
BL23	1	1	1	1	0	0	0	0	0	4
BL24	0	0	0	0	0	0	1	1	0	2
BL25	0	0	0	0	1	1	1	1	0	4

DBI ON case										No. of 1's
	DQ[7]	DQ[6]	DQ[5]	DQ[4]	DQ[3]	DQ[2]	DQ[1]	DQ[0]	DBI	
BL26	0	0	0	0	0	0	1	1	1	3
BL27	1	1	1	1	0	0	0	0	0	4
BL28	0	0	0	0	0	0	0	0	1	1
BL29	1	1	1	1	0	0	0	0	0	4
BL30	0	0	0	0	0	0	0	0	0	0
BL31	0	0	0	0	1	1	1	1	0	4
No. of 1's	8	8	8	8	8	8	16	16	8	

Notes:

1. Green colored cells are DBI enabled burst.

**Table - Data Pattern for IDD4R (DBI on)**

DBI OFF case										No. of 1's
	DQ[7]	DQ[6]	DQ[5]	DQ[4]	DQ[3]	DQ[2]	DQ[1]	DQ[0]	DBI	
BL0	0	0	0	0	0	0	0	0	1	1
BL1	1	1	1	1	0	0	0	0	0	4
BL2	0	0	0	0	0	0	0	0	0	0
BL3	0	0	0	0	1	1	1	1	0	4
BL4	0	0	0	0	0	0	1	1	0	2
BL5	0	0	0	0	1	1	1	1	0	4
BL6	0	0	0	0	0	0	1	1	1	3
BL7	1	1	1	1	0	0	0	0	0	4
BL8	0	0	0	0	0	0	0	0	1	1
BL9	1	1	1	1	0	0	0	0	0	4
BL10	0	0	0	0	0	0	0	0	0	0
BL11	0	0	0	0	1	1	1	1	0	4
BL12	0	0	0	0	0	0	1	1	0	2
BL13	0	0	0	0	1	1	1	1	0	4
BL14	0	0	0	0	0	0	1	1	1	3
BL15	1	1	1	1	0	0	0	0	0	4
BL16	0	0	0	0	0	0	0	0	1	1
BL17	1	1	1	1	0	0	0	0	0	4
BL18	0	0	0	0	0	0	0	0	0	0
BL19	0	0	0	0	1	1	1	1	0	4
BL20	0	0	0	0	0	0	1	1	1	3
BL21	1	1	1	1	0	0	0	0	0	4
BL22	0	0	0	0	0	0	1	1	0	2
BL23	0	0	0	0	1	1	1	1	0	4
BL24	0	0	0	0	0	0	0	0	0	0
BL25	0	0	0	0	1	1	1	1	0	4
BL26	0	0	0	0	0	0	0	0	1	1
BL27	1	1	1	1	0	0	0	0	0	4
BL28	0	0	0	0	0	0	1	1	0	2
BL29	0	0	0	0	1	1	1	1	0	4

DBI OFF case										No. of 1's
	DQ[7]	DQ[6]	DQ[5]	DQ[4]	DQ[3]	DQ[2]	DQ[1]	DQ[0]	DBI	
BL30	0	0	0	0	0	0	1	1	1	3
BL31	1	1	1	1	0	0	0	0	0	4
No. of 1's	8	8	8	8	8	8	16	16	8	

Notes:

1. Green colored cells are DBI enabled burst.

## 8.2. IDD Specifications

IDD values are for the entire operating voltage range, and all of them are for the entire standard range, with the exception of IDD6ET which is for the entire extended temperature range

### LPDDR4 IDD Specification Parameters and Operating Conditions

- \* Published IDD values are the maximum of the distribution of the arithmetic mean except IDD6 25°C/IDD6 105°C
- \* ODT disabled: MR11[2:0] = 000B.
- \* IDD current specifications are tested after the device is properly initialized.
- \* For all IDD measurements, VIHCKE = 0.8 x VDD2, VILCKE = 0.2 x VDD2.

Parameter/Condition	Symbol	Power Supply	3200	3733	Units	Notes
<b>Operating one bank active-precharge current:</b> tCK = tCKmin; tRC = tRCmin; CKE is HIGH; CS is LOW between valid commands; CA bus inputs are switching; Data bus inputs are stable; ODT disabled	IDD0 <sub>1</sub>	VDD1	12.00	12.00	mA	
	IDD0 <sub>2</sub>	VDD2	25.00	25.00	mA	
	IDD0 <sub>Q</sub>	VDDQ	1.50	1.50	mA	
<b>Idle power-down standby current:</b> tCK = tCKmin; CKE is LOW; CS is LOW; All banks are idle; CA bus inputs are switching; Data bus inputs are stable; ODT disabled	IDD2P <sub>1</sub>	VDD1	0.20	0.20	mA	
	IDD2P <sub>2</sub>	VDD2	1.30	1.30	mA	
	IDD2P <sub>Q</sub>	VDDQ	0.05	0.05	mA	
<b>Idle power-down standby current with clock stop:</b> CK_t =LOW, CK_c =HIGH; CKE is LOW; CS is LOW; All banks are idle; CA bus inputs are stable; Data bus inputs are stable ODT disabled	IDD2PS <sub>1</sub>	VDD1	0.20	0.20	mA	
	IDD2PS <sub>2</sub>	VDD2	1.30	1.30	mA	
	IDD2PS <sub>Q</sub>	VDDQ	0.05	0.05	mA	
<b>Idle non power-down standby current:</b> tCK = tCKmin; CKE is HIGH; CS is LOW; All banks are idle; CA bus inputs are switching; Data bus inputs are stable ODT disabled	IDD2N <sub>1</sub>	VDD1	0.20	0.02	mA	
	IDD2N <sub>2</sub>	VDD2	15.00	15.00	mA	
	IDD2N <sub>Q</sub>	VDDQ	1.50	1.50	mA	

Parameter / Condition	Symbol	Power Supply	3200	3733	Units	Notes
<b>Idle non power-down standby current with clock stopped:</b> CK_t=LOW; CK_c=HIGH; CKE is HIGH; CS is LOW; All banks are idle; CA bus inputs are stable; Data bus inputs are stable ODT disabled	IDD2NS <sub>1</sub>	VDD1	0.20	0.20	mA	
	IDD2NS <sub>2</sub>	VDD2	12.00	12.00	mA	
	IDD2NS <sub>Q</sub>	VDDQ	1.50	1.50	mA	
<b>Active power-down standby current:</b> tCK = tCKmin; CKE is LOW; CS is LOW; One bank is active; CA bus inputs are switching; Data bus inputs are stable ODT disabled	IDD3P <sub>1</sub>	VDD1	3.00	3.00	mA	
	IDD3P <sub>2</sub>	VDD2	3.00	3.00	mA	
	IDD3P <sub>Q</sub>	VDDQ	0.05	0.05	mA	
<b>Active power-down standby current with clock stop:</b> CK_t=LOW, CK_c=HIGH; CKE is LOW; CS is LOW; One bank is active; CA bus inputs are stable; Data bus inputs are stable ODT disabled	IDD3PS <sub>1</sub>	VDD1	3.00	3.00	mA	
	IDD3PS <sub>2</sub>	VDD2	3.00	3.00	mA	
	IDD3PS <sub>Q</sub>	VDDQ	0.05	0.05	mA	
<b>Active non-power-down standby current:</b> tCK = tCKmin; CKE is HIGH; CS is LOW; One bank is active; CA bus inputs are switching; Data bus inputs are stable ODT disabled	IDD3N <sub>1</sub>	VDD1	3.00	3.00	mA	
	IDD3N <sub>2</sub>	VDD2	15.00	15.00	mA	
	IDD3N <sub>Q</sub>	VDDQ	1.50	1.50	mA	
<b>Active non-power-down standby current with clock stopped:</b> CK_t=LOW, CK_c=HIGH; CKE is HIGH; CS is LOW; One bank is active; CA bus inputs are stable; Data bus inputs are stable ODT disabled	IDD3NS <sub>1</sub>	VDD1	3.00	3.00	mA	
	IDD3NS <sub>2</sub>	VDD2	12.00	12.00	mA	
	IDD3NS <sub>Q</sub>	VDDQ	1.50	1.50	mA	
<b>Operating burst READ current:</b> tCK = tCKmin; CS is LOW between valid commands; One bank is active; BL = 16 or 32; RL = RL(MIN); CA bus inputs are switching; 50% data change each burst transfer ODT disabled	IDD4R <sub>1</sub>	VDD1	8.00	8.50	mA	
	IDD4R <sub>2</sub>	VDD2	160.00	180.00	mA	
	IDD4R <sub>Q</sub>	VDDQ	70.00	72.00	mA	1
<b>Operating burst WRITE current:</b> tCK = tCKmin; CS is LOW between valid commands; One bank is active; BL = 16 or 32; WL = WLmin; CA bus inputs are switching; 50% data change each burst transfer ODT disabled	IDD4W <sub>1</sub>	VDD1	8.00	8.5	mA	
	IDD4W <sub>2</sub>	VDD2	150.00	170.00	mA	
	IDD4W <sub>Q</sub>	VDDQ	1.00	1.00	mA	

Parameter/Condition	Symbol	Power Supply	3200	3733	Units	Notes
<b>All-bank REFRESH Burst current:</b> tCK = tCKmin; CKE is HIGH between valid commands; tRC = tRFCabmin; Burst refresh; CA bus inputs are switching; Data bus inputs are stable; ODT disabled	IDD5 <sub>1</sub>	VDD1	12.00	12.00	mA	
	IDD5 <sub>2</sub>	VDD2	25.00	25.00	mA	
	IDD5 <sub>Q</sub>	VDDQ	1.50	1.50	mA	
<b>All-bank REFRESH Average current:</b> tCK = tCKmin; CKE is HIGH between valid commands; tRC = tREFI; CA bus inputs are switching; Data bus inputs are stable; ODT disabled	IDD5AB <sub>1</sub>	VDD1	1.00	1.00	mA	
	IDD5AB <sub>2</sub>	VDD2	15.00	15.00	mA	
	IDD5AB <sub>Q</sub>	VDDQ	1.50	1.50	mA	
<b>Per-bank REFRESH Average current:</b> tCK = tCKmin; CKE is HIGH between valid commands; tRC = tREFI/8; CA bus inputs are switching; Data bus inputs are stable; ODT disabled	IDD5PB <sub>1</sub>	VDD1	1.00	1.00	mA	
	IDD5PB <sub>2</sub>	VDD2	15.00	15.00	mA	
	IDD5PB <sub>Q</sub>	VDDQ	1.50	1.50	mA	
<b>Self refresh current (85°C):</b> CK <sub>t</sub> =LOW, CK <sub>c</sub> =HIGH; CKE is LOW; CA bus inputs are stable; Data bus inputs are stable; Maximum 1x Self-Refresh Rate; ODT disabled	IDD6 <sub>1</sub>	VDD1	0.40	0.40	mA	2,3,4
	IDD6 <sub>2</sub>	VDD2	1.60	1.60	mA	2,3,4
	IDD6 <sub>Q</sub>	VDDQ	0.05	0.05	mA	2,3,4
<b>Self refresh current (25°C):</b> CK <sub>t</sub> =LOW, CK <sub>c</sub> =HIGH; CKE is LOW; CA bus inputs are stable; Data bus inputs are stable; ODT disabled	IDD6 <sub>1</sub>	VDD1	0.045	0.045	mA	2,3,4
	IDD6 <sub>2</sub>	VDD2	0.10	0.10	mA	2,3,4
	IDD6 <sub>Q</sub>	VDDQ	0.01	0.01	mA	2,3,4
<b>Self refresh current (105°C):</b> CK <sub>t</sub> =LOW, CK <sub>c</sub> =HIGH; CKE is LOW; CA bus inputs are stable; Data bus inputs are stable; ODT disabled	IDD6ET <sub>1</sub>	VDD1	0.75	0.75	mA	2,3,5
	IDD6ET <sub>2</sub>	VDD2	1.80	1.80	mA	2,3,5
	IDD6ET <sub>Q</sub>	VDDQ	0.03	0.03	mA	2,3,5

**Notes:**

1. Guaranteed by design with output load = 5pF and RON = 40 ohm.
2. This is the general definition that applies to full array Self Refresh.
3. Supplier datasheets may contain additional Self Refresh IDD values for temperature subranges within the Standard or elevated Temperature Ranges.
4. IDD6 85°C is guaranteed, IDD6 25°C is typical of the distribution of the arithmetic mean.
5. IDD6ET is a typical value, is sampled only, and is not tested.

### 9. Electrical Characteristics and AC Timings

#### 9.1. AC Timing Parameters

**Table - Core Parameters**

Parameter	Symbol	min max	Data Rate							Unit	Note
			533	1066	1600	2133	2667	3200	3733		
ACTIVE to ACTIVE command period	tRC	min	tRAS + tRPab (with all-bank precharge) tRAS + tRPpb (with per-bank precharge)							ns	
Minimum Self-Refresh Time (Entry to Exit)	tSR	min	max(15ns, 3nCK)							ns	
Self Refresh exit to next valid command delay	tXSR	min	max(tRFCab + 7.5ns, 2nCK)							ns	
Exit power down to next valid command delay	tXP	min	max(7.5ns, 5nCK)							ns	
CAS to CAS delay	tCCD	min	8							tCK(avg)	2
CAS to CAS delay Masked Write w/ECC	tCCDMW	min	4 * tCCD							tCK(avg)	
Internal Read to Precharge command delay	tRTP	min	max(7.5ns, 8nCK)							ns	
RAS to CAS Delay	tRCD	min	max(18ns, 4nCK)							ns	
Row Precharge Time (single bank)	tRPpb	min	max(18ns, 4nCK)							ns	
Row Precharge Time (all banks) - 8-bank	tRPab	min	max(21ns, 4nCK)							ns	
Row Active Time	tRAS	min	max(42ns, 3nCK)							ns	
		max	min(9 * tREFI * Refresh Rate, 70.2)							us	3
Write Recovery Time	tWR	min	max{18ns, 4nCK}							ns	
Write to Read Command Delay	tWTR	min	max(10ns, 8nCK)							ns	
Active bank A to Active bank B	tRRD	min	max(10ns, 4nck)							ns	
Precharge to Precharge Delay	tPPD	min	4							tCK	
Four Bank Activate Window	tFAW	min	40							ns	

**Notes:**

1. Precharge to precharge timing restriction does not apply to Auto-Precharge commands.
2. The value is based on BL16. For BL32 need additional 8 tCK(avg) delay.
3. Refresh Rate is specified by MR4 OP[2:0].

**Table - Clock timings**

Parameter	Symbol	min max	LPDDR4	LPDDR4	LPDDR4	LPDDR4	Unit	Note
			1600	2400	3200	4200		
<b>Clock Timing</b>								
Average Clock Period	tCK(avg)	min	1.25	0.833	0.625	0.467	ns	
		max	100	100	100	100		
Average high pulse width	tCH(avg)	min	0.46	0.46	0.46	tbd	tCK(avg)	
		max	0.54	0.54	0.54	tbd		
Average low pulse width	tCL(avg)	min	0.46	0.46	0.46	tbd	tCK(avg)	
		max	0.54	0.54	0.54	tbd		
Absolute Clock Period	tCK(abs)	min	tCK(avg)min + tJIT(per)min				ns	
		max	-					
Absolute clock HIGH pulse width	tCH(abs)	min	0.43	0.43	0.43	tbd	tCK(avg)	
		max	0.57	0.57	0.57	tbd		
Absolute clock LOW pulse width	tCL(abs)	min	0.43	0.43	0.43	tbd	tCK(avg)	
		max	0.57	0.57	0.57	tbd		
Clock Period Jitter	tJIT(per)	min	-70	-50	-40	tbd	ps	
		max	70	50	40	tbd		
Maximum Clock Jitter between two consecutive clock cycles	tJIT(cc)	min	-				ps	
		max	140	100	80	tbd		

**Table - ZQ Calibration timings**

Parameter	Symbol	min max	DDR4	DDR4	DDR4	DDR4	DDR4	DDR4	DDR4	Unit	Note
			533	1066	1600	2133	2667	3200	3733		
ZQ Calibration Time	tZQCAL	max	1							us	
ZQ Calibration Latch Quiet Time	tZQLAT	max	max(30ns, 8nCK)							ns	
Calibration Reset Time	tZQRESET	max	max(50ns, 3nCK)							ns	

**Table - DQ Tx Voltage and Timings (Read Timing parameters)**

Parameter	Symbol	min max	1600/ 1867	2133/ 2400	3200	4266	Unit	Note
<b>Data Timing</b>								
DQS_t,DQS_c to DQ Skew	tDQSQ	max	0.18				UI	1
DQ output hold time total from DQS_t, DQS_c (DBI-Disabled)	tQH	min	min(tQSH, tQSL)				UI	1
DQ output window time total, per pin (DBI-Disabled)	tQW_total	min	0.75	0.73	0.7	0.7	UI	1,4
DQ output window time deterministic, per pin (DBI-Disabled)	tQW_dj	min	tbd	tbd	tbd	tbd	UI	1,4,3
DQS_t, DQS_c to DQ Skew total, per group, per access (DBI-Enabled)	tDQSQ_DBI	max	0.18				UI	1
DQ output hold time total from DQS_t, DQS_c (DBI-enabled)	tQH_DBI	min	min(tQSH_DBI, tQSL_DBI)				UI	1
DQ output window time total, per pin (DBI-enabled)	tQW_total_DBI	min	0.75	0.73	0.7	0.7	UI	1,4
Read preamble	tRPRE	min	1.8				tCK(avg)	
Read postamble	tRPST	min	0.4				tCK(avg)	
Extended Read postamble	tRPSTE	min	1.4				tCK(avg)	
DQS Low-impedance time from CK_t, CK_c	tLZ(DQS)	min	$(RL \times tCK) + tDQSCK(\text{Min}) - (tPRE(\text{Max}) \times tCK) - 200\text{ps}$				ps	
DQS High-impedance time from CK_t, CK_c	tHZ(DQS)	max	$(RL \times tCK) + tDQSCK(\text{Max}) + (RPST(\text{Max}) \times tCK) - 100\text{ps}$				ps	
DQ Low-impedance time from CK_t, CK_c	tLZ(DQ)	min	$(RL \times tCK) + tDQSCK(\text{Min}) - 200\text{ps}$				ps	
DQ High-impedance time from CK_t, CK_c	tHZ(DQ)	max	$(RL \times tCK) + tDQSCK(\text{Max}) + tDQSQ(\text{Max}) + (BL/2 \times tCK) - 100\text{ps}$				ps	
<b>Data Strobe Timing</b>								
DQS output access time from CK/CK#	tDQSCK	min	1.5				ns	8
		max	3.5					
DQSCK Temperature Drift	tDQSCK_temp	max	4				ps/C	9
DQSCK Volgate Drift	tDQSCK_volt	max	7				ps/mV	10
CK to DQS Rank to Rank variation	tDQSCK_rank2rank	max	1.0				ns	11,12
DQS Output Low Pulse Width (DBI Disabled)	tQSL	min	tCL(abs)-0.05				tCK(avg)	4,5
DQS Output High Pulse Width (DBI Disabled)	tQSH	min	tCH(abs)-0.05				tCK(avg)	4,6
DQS Output Low Pulse Width (DBI Enabled)	tQSL_DBI	min	tCL(abs)-0.045				tCK(avg)	5,7
DQS Output High Pulse Width (DBI Enabled)	tQSH_DBI	min	tCH(abs)-0.045				tCK(avg)	6,7

**Notes:**

- 1.DQ to DQS differential jitter where the total includes the sum of deterministic and random timing terms for a specified BER. BER spec and measurement method are **tbd**.
- 2.The deterministic component of the total timing. Measurement method **tbd**.
- 3.This parameter will be characterized and guaranteed by design.
- 4.This parameter is function of input clock jitter. These values assume the min tCH(abs) and tCL(abs). When the input clock jitter min tCH(abs) and tCL(abs) is 0.44 or greater of tck(avg) the min value of tQSL will be tCL(abs)-0.04 and tQSH will be tCH(abs) - 0.04.
- 5.tQSL describes the instantaneous differential output low pulse width on DQS\_t - DQS\_c, as measured from on falling edge to the next consecutive rising edge
- 6.tQSH describes the instantaneous differential output high pulse width on DQS\_t - DQS\_c, as measured from on falling edge to the next consecutive rising edge
- 7.This parameter is function of input clock jitter. These values assume the min tCH(abs) and tCL(abs).
8. Includes DRAM process, voltage and temperature variation. It includes the AC noise impact for frequencies > 20 MHz and max



voltage of 45 mV pk-pk from DC-20 MHz at a fixed temperature on the package. The voltage supply noise must comply to the component Min-Max DC Operating conditions.

9. tDQSCK\_temp max delay variation as a function of Temperature.
10. tDQSCK\_volt max delay variation as a function of DC voltage variation for VDDQ and VDD2. tDQSCK\_volt should be used to calculate timing variation due to VDDQ and VDD2 noise < 20 MHz. Host controller do not need to account for any variation due to VDDQ and VDD2 noise > 20 MHz. The voltage supply noise must comply to the component Min-Max DC Operating conditions. The voltage variation is defined as the  $\text{Max}\{\text{abs}\{\text{tDQSCKmin@V1}-\text{tDQSCKmax@V2}\}, \text{abs}\{\text{tDQSCKmax@V1}-\text{tDQSCKmin@V2}\}\} / \text{abs}\{V1-V2\}$ . For tester measurement VDDQ = VDD2 is assumed.
11. The same voltage and temperature are applied to tDQS2CK\_rank2rank.
12. tDQSCK\_rank2rank parameter is applied to multi-ranks per byte lane within a package consisting of the same design dies.
13.  $\text{UI}=\text{tCK}(\text{avg})_{\text{min}}/2$

**Table - DQ Rx Voltage and Timing Parameters (Write Timing Parameters)**

Symbol	Parameter	min max	1600/1867 <sup>A)</sup>	2133/2400	3200	4266	Unit	Note
VdIVW_total	Rx Mask voltage p-p total	max	140	140	140	120	mV	1,2,3,5
VdIVW_dV	Rx Mask voltage - deterministic	max	tbd	tbd	tbd	tbd	mV	1,5
TdIVW_total	Rx timing window total (At VdIVW voltage levels)	max	0.22	0.22	0.25	0.25	UI	1,2,4,5
TdIVW_dj	Rx deterministic timing	max	tbd	tbd	tbd	tbd	UI	1,5
TdIVW_1bit	Rx timing window 1bit toggle (At VdIVW voltage levels)	max	tbd	tbd	tbd	tbd	UI	1,2,4,5 ,14
VIHL_AC	DQ AC input pulse amplitude p-p	min	180	180	180	170	mV	7,15
TdIPW	DQ input pulse width (At Vcent_DQ)	min	0.45	0.45	0.45	0.45	UI	8
TDQS2DQ	DQ to DQS offset	min	200	200	200	200	ps	9
		max	800	800	800	800		
TDQDQ	DQ to DQ offset	max	30	30	30	30	ps	10
TDQS2DQ_temp	DQ to DQS offset temperature variation	max	0.6	0.6	0.6	0.6	ps/°C	11
TDQS2DQ_volt	DQ to DQS offset voltage variation	max	33	33	33	33	ps/50mV	12
TDQS2DQ_rank2rank	DQ to DQS offset rank to rank	max	200	200	200	200	ps	17,18
tDQSS	Write command to 1st DQS latching transition	min	0.75				tCK(avg)	
		max	1.25					
tDQSH	DQS input high-level width	min	0.4				tCK(avg)	
tDQSL	DQS input low-level width	min	0.4				tCK(avg)	
tDSS	DQS falling edge to CK setup time	min	0.2				tCK(avg)	
tDSH	DQS falling edge hold time from CK	min	0.2				tCK(avg)	
tWPRE	Write preamble	min	1.8				tCK(avg)	
tWPST	0.5 tCK Write postamble	min	0.4				tCK(avg)	
tWPSTE	1.5 tCK Write postamble	min	1.4				tCK(avg)	
SRIN_dIVW	Input slew rate over VdIVW_total	min	1	1	1	1	V/ns	13
		max	7	7	7	7		

Notes:

1. Data Rx mask voltage and timing parameters are applied per pin and includes the DRAM DQ to DQS voltage AC noise impact for frequencies >250KHz at a fixed temperature on the package. The voltage supply noise must comply to the component Min-Max DC operating conditions.
2. The design specification is a BER <tbd. The BER will be characterized and extrapolated if necessary using a dual dirac method.
3. Rx mask voltage VdIVW total(max) must be centered around Vcent\_DQ(pin\_mid).
4. Rx differential DQ to DQS jitter total timing window at the VdIVW voltage levels.
5. Defined over the DQ internal Vref range. The Rx mask at the pin must be within the internal Vref DQ range irrespective of the input signal common mode.
6. Deterministic component of the total Rx mask voltage or timing. Parameter will be characterized and guaranteed by design. Measurement method **tbd**
7. DQ only input pulse amplitude into the receiver must meet or exceed VIHL AC at any point over the total UI. No timing requirement above level. VIHL AC is the peak to peak voltage centered around Vcent\_DQ(pin\_mid) such that VIHL\_AC/2 min must be met both above and below Vcent\_DQ.
8. DQ only minimum input pulse width defined at the Vcent\_DQ(pin\_mid).
9. DQ to DQS offset is within byte from DRAM pin to DRAM internal latch. Includes all DRAM process, voltage and temperature vari-

ation.

10. DQ to DQ offset defined within byte from DRAM pin to DRAM internal latch for a given component.
11. TDQS2DQ max delay variation as a function of temperature.
12. TDQS2DQ max delay variation as a function of the DC voltage variation for VDDQ and VDD2.
13. Input slew rate over VdIVW Mask centered at Vcent\_DQ(pin\_mid).
14. Rx mask defined for a one pin toggling with other DQ signals in a steady state.
15. VIH<sub>L</sub>\_AC does not have to be met when no transitions are occurring.
16. The same voltage and temperature are applied to tDQS2DQ\_rank2rank.
17. tDQS2DQ\_rank2rank parameter is applied to multi-ranks per byte lane within a package consisting of the same design dies.

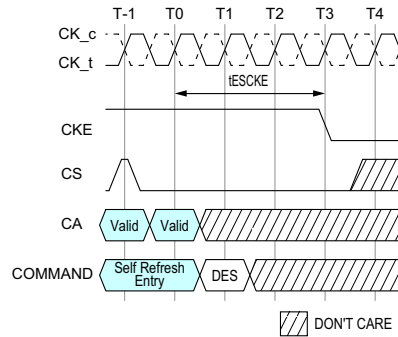
A. The following Rx voltage and timing requirements apply for all DQ operating frequencies at or below 1600 for all speed bins. The timing parameters in UI can be converted to absolute time values where  $t_{ck}(avg)_{min}/2 = 625ps$  for DQ=1600. For example the  $TdIVW_{total}(ps) = 0.22 * 625ps = 137.5ps$ .

**Table - Self-Refresh Timing Parameters**

Parameter	Symbol	min max	DDR4	DDR4	DDR4	DDR4	DDR4	DDR4	DDR4	DDR4	Unit	Note
			533	1066	1600	2133	2667	3200	3733	4267		
Delay from Self Refresh Entry to CKE Input Low	tESCKE	min	max(1.75ns, 3tCK)								nCK	1
Minimum Self-Refresh Time (Entry to Exit)	tSR	min	max(15ns, 3nCK)								ns	1
Self refresh exit to next valid command delay	tXSR	min	max(tRFCab + 7.5ns, 2nCK)								ns	1,2

Note

1. Delay time has to satisfy both analog time(ns) and clock count(tCK). It means that tESCKE will not expire until CK has toggled through at least 3 full cycles (3 \*tCK) and 1.75ns has transpired. The case which 3tCK is applied to is shown below.



2. MRR-1, CAS-2, SRX, MPC, MRW-1, and MRW-2 commands (except PASR bank/segment setting) are only allowed during this period.

**Table - Command Address Input Parameters**

Symbol	Parameter	min max	DQ-1333 <sup>A</sup> )	DQ-1600/ 1867	DQ-3200	DQ-4266	Unit	Note
VcIVW	Rx Mask voltage p-p	max	175	175	155	145	mV	1,2,4
tcIVW	Rx timing window	max	0.3	0.3	0.3	0.3	UI	1,2,3,4
VIHL_AC	CA AC input pulse amplitude pk-pk	min	210	210	190	180	mV	5,8
TcIPW	CA input pulse width	min	0.55	0.55	0.6	0.6	UI	6
SRIN_cIVW	Input slew rate over VcIVW	min	1	1	1	1	V/ns	7
		max	7	7	7	7		

Notes:

1. CA Rx mask voltage and timing parameters at the pin including voltage and temperature drift.
2. Rx mask voltage VcIVW total(max) must be centered around Vcent\_CA(pin mid).
3. Rx differential CA to CK jitter total timing window at the VcIVW voltage levels.
4. Defined over the CA internal Vref range. The Rx mask at the pin must be within the internal Vref CA range irrespective of the input signal common mode.

5. CA only input pulse signal amplitude into the receiver must meet or exceed VIH<sub>L</sub> AC at any point over the total UI. No timing requirement above level. VIH<sub>L</sub> AC is the peak to peak voltage centered around Vcent\_CA(pin mid) such that VIH<sub>L</sub>\_AC/2 min must be met both above and below Vcent\_CA.
  6. CA only minimum input pulse width defined at the Vcent\_CA(pin mid).
  7. Input slew rate over VcIVW Mask centered at Vcent\_CA(pin mid).
  8. VIH<sub>L</sub>\_AC does not have to be met when no transitions are occurring.
  9. UI=tCK(avg)min/2
- A. The following Rx voltage and timing requirements apply for DQ operating frequencies at or below 1333 for all speed bins. The timing parameters in UI can be converted to absolute time values where tck(avg)min= 1.5ns for DQ=1333. For example the TcIVW(ps) = 0.3\*1.5ns=450ps.

**Table - Boot Parameters**

Parameter	Symbol	min max	DDR4	DDR4	DDR4	DDR4	DDR4	DDR4	DDR4	DDR4	Unit	Note	
			533	1066	1600	2133	2667	3200	3733	4267			
Clock Cycle Time	tCKb	min	Note 1, 2									ns	
		max	Note 1, 2										
Address & Control Input Setup Time	tISb	min	1150									ps	
Address & Control Input Hold Time	tIHb	min	1150									ps	
DQS Output Data Access Time from CK/CK#	tDQ <sub>SCKb</sub>	min	2									ns	
		max	10										
Data Strobe Edge to Output Data Edge tDQ <sub>SQb</sub>	tDQ <sub>SQb</sub>	max	1.2									ns	

Notes

1. Min tCKb guaranteed by DRAM test is 18ns.
2. The system may boot at a higher frequency than dictated by min tCKb. The higher boot frequency is system dependent

**Table - Mode Register Parameters**

Parameter	Symbol	min max	DDR4	DDR4	DDR4	DDR4	DDR4	DDR4	DDR4	DDR4	Unit	Note	
			533	1066	1600	2133	2667	3200	3733	4267			
Additional time after tXP has expired until the MRR command may be issued	tM <sub>RRI</sub>	min	tRC <sub>D</sub> + 3nCK									ns	
MODE REGISTER Write command period	tM <sub>RW</sub>	min	max(10ns, 10nCK)									ns	
MODE REGISTER Read command period	tM <sub>RR</sub>	min	8									nCK	
Mode Register Write Set Command Delay	tM <sub>RD</sub>	min	max(14ns, 10nCK)									ns	

**Table - VRCG Enable/Disable Timing**

Parameter	Symbol	min max	DDR4	DDR4	DDR4	DDR4	DDR4	DDR4	DDR4	DDR4	Unit	Note	
			533	1066	1600	2133	2667	3200	3733	4267			
VREF high current mode enable time	tVRCG_Enable	max	200									ns	
VREF high current mode disable time	tVRCG_Disable	max	100									ns	

**Table - Command Bus Training Parameters**

Parameter	Symbol	min max	DDR4	DDR4	DDR4	DDR4	DDR4	DDR4	DDR4	DDR4	Unit	Note	
			533	1066	1600	2133	2667	3200	3733	4267			
Clock and Command Valid after CKE Low	tCKELCK	min	max(7.5ns, 5nCK)									tCK	
Data Setup for Vref Training Mode	tD <sub>Strain</sub>	min	2									ns	
Data Hold for Vref Training Mode	tD <sub>Htrain</sub>	min	2									ns	
Asynchronous Data Read	tADR	max	20									ns	
CA Bus Training Command to CA Bus Training Command Delay	tCACD	min	RU(tADR/tCK)									tCK	2
Valid Strobe Requirement before CKE Low	tDQ <sub>SCKE</sub>	min	10									ns	1
First CA Bus Training Command Following CKE Low	tCAENT	min	250									ns	
Vref Step Time – multiple steps	tVref_long	max	250									ns	

Parameter	Symbol	min max	DDR4	DDR4	DDR4	DDR4	DDR4	DDR4	DDR4	DDR4	Unit	Note	
			533	1066	1600	2133	2667	3200	3733	4267			
Vref Step Time – one step	tVref_short	max	80									ns	
Valid Clock Requirement before CS High	tCKPRECS	min	2*tCK + tXP									-	
Valid Clock Requirement after CS High	tCKPSTCS	min	max(7.5ns, 5nCK)									-	
Minimum delay from CS to DQS toggle in command bus training	tCS_Vref	min	2									tCK	
Minimum delay from CKE High to Strobe High Impedance	tCKEHDQS	min	10									ns	
Clock and Command valid before CKE HIGH	tCKCKEH	min	2									tCK	
CA Bus Training CKE High to DQ Tri-state	tMRZ	min	1.5									ns	
ODT turn-on latency from CKE	tCKELODton	min	20									ns	
ODT turn-off latency from CKE	tCKELODtoff	min	20									ns	

Notes:

1. DQS\_t has to retain a low level during tDQSCKE period, as well as DQS\_c has to retain a high level.
2. If tCACD is violated, the data for samples which violate tCACD will not be available, except for the last sample (where tCACD after this sample is met). Valid data for the last sample will be available after tADR.

**Table - Write Leveling Parameters**

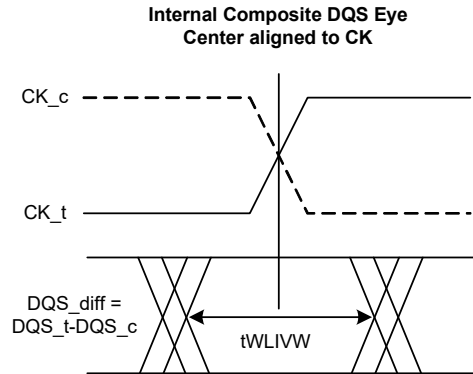
Parameter	Symbol	min max	DDR4	DDR4	DDR4	DDR4	DDR4	DDR4	DDR4	DDR4	Unit	Note	
			533	1066	1600	2133	2667	3200	3733	4267			
DQS_t/DQS_c delay after write leveling mode is programmed	tWLDQSEN	min	20									tCK	
Write preamble for Write Leveling	tWLWPRE	min	20									tCK	
First DQS_t/DQS_c edge after write leveling mode is programmed	tWLMRD	min	40									tCK	
Write leveling output delay	tWLO	min	0									ns	
		max	20										
Valid Clock Requirement before DQS Toggle	tCKPRDQS	min	max(7.5ns, 4nCK)										
Valid Clock Requirement after DQS Toggle	tCKPSTDQS	min	max(7.5ns, 4nCK)										
Write leveling hold time	tWLH	min			150	100		75		50	ps	1,2	
Write leveling setup time	tWLS	min			150	100		75		50	ps	1,2	
Write leveling invalid window	tWLIVW_Total	min			240	160		120		90	ps	1,2	

Notes:

1. In addition to the traditional setup and hold time specifications above, there is value in a invalid window based specification for write-leveling training. As the training is based on each device, worst case process skews for setup and hold do not make sense to close timing between CK and DQS.
2. tWLIVW\_Total is defined in a similar manner to tDIVW\_Total, except that here it is a DQS invalid window with respect to CK. This would need to account for all VT (voltage and temperature) drift terms between CK and DQS within the DRAM that affect the write-leveling invalid window.

The DQS input mask for timing with respect to CK is shown in the following figure. The "total" mask (TdiVW\_total) defines the time the input signal must not encroach in order for the DQS input to be successfully captured by CK with a BER of lower than tbd. The mask is a receiver property and it is not the valid data-eye.

**Figure - DQS\_t/DQS\_c and CK\_t/CK\_c at DRAM Latch**



**Table - Read Preamble Training Timings**

Parameter	Symbol	min max	DDR4	DDR4	DDR4	DDR4	DDR4	DDR4	DDR4	DDR4	Unit	Note
			533	1066	1600	2133	2667	3200	3733	4267		
Delay from MRW command to DQS Driven out	tSDO	max	min(tMRD, 15ns)								tCK	1

**Table - MPC [Write FIFO] AC Timing**

Parameter	Symbol	min max	DDR4	DDR4	DDR4	DDR4	DDR4	DDR4	DDR4	DDR4	Unit	Note
			533	1066	1600	2133	2667	3200	3733	4267		
Additional time after tXP has expired until MPC [Write FIFO] command may be issued	tMPCWR	min	tRCD + 3nCK									

**Table - DQS Interval Oscillator AC Timing**

Parameter	Symbol	min max	Value								Unit	Note
			max(40ns, 8nCK)									
Delay time from OSC stop to Mode Register Readout	tOSCO	min	max(40ns, 8nCK)								ns	

**Table - Frequency Set Point Timing**

Parameter	Symbol	min max	DDR4	DDR4	DDR4	DDR4	DDR4	DDR4	DDR4	DDR4	Unit	Note
			533	1066	1600	2133	2667	3200	3733	4267		
Frequency Set Point Switching Time	tFC_Short	min	200								ns	1
	tFC_Middle	min	200								ns	1
	tFC_Long	min	250								ns	1
Valid Clock Requirement after entering FSP change	tCKFSPE	min	max(7.5ns, 4nCK)									
Valid Clock Requirement before 1st valid command after FSP change	tCKFSPX	min	max(7.5ns, 4nCK)									

Notes:

- Frequency Set Point Switching Time depends on value of Vref(ca) setting: MR12 OP[5:0] and Vref(ca) Range: MR12 OP[6] of FSP-OP 0 and 1. The details are shown in Table "tFC value mapping".  
Additionally change of Frequency Set Point may affect Vref(dq) setting. Setting time of Vref(dq) level is same as Vref(ca) level.

**Table - CA ODT setting timing**

Parameter	Symbol	Min/Max	LPDDR4-1600/1866/2133/2400/3200/4266	Units	Note
ODT CA Value Update Time	tODTUP	Min	RU(tbd ns/tCK(avg))		

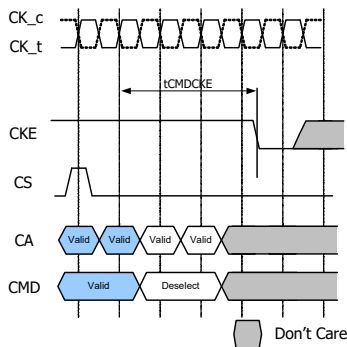
**Table - Power Down Timing**

Parameter	Symbol	min max	DDR4	DDR4	DDR4	DDR4	DDR4	DDR4	DDR4	Unit	Note	
			533	1066	1600	2133	2667	3200	3733			4267
CKE minimum pulse width (HIGH and LOW pulse width)	tCKE	min	Max(7.5ns,4nCK)								-	
Delay from valid command to CKE input LOW	tCMDCKE	min	Max(1.75ns,3nCK)								ns	1
Valid Clock Requirement after CKE Input low	tCKELCK	min	Max(5ns,5nCK)								ns	1
Valid CS Requirement before CKE Input Low	tCSCKE	min	1.75								ns	
Valid CS Requirement after CKE Input low	tCKELCS	min	Max(5ns, 5nCK)								ns	
Valid Clock Requirement before CKE Input High	tCKCKEH	min	Max(1.75ns, 3nCK)								ns	1
Exit power- down to next valid command delay	tXP	min	Max(7.5ns, 5nCK)								ns	1
Valid CS Requirement before CKE Input High	tCSCKEH	min	1.75								ns	
Valid CS Requirement after CKE Input High	tCKEHCS	min	Max(7.5ns, 5nCK)								ns	
Valid Clock and CS Requirement after CKE Input low after MRW Command	tMRWCKEL	min	Max(14ns, 10nCK)								ns	1
Valid Clock and CS Requirement after CKE Input low after ZQ Calibration Start Command	tZQCKE	min	Max(1.75ns, 3nCK)								ns	1

Notes:

1. Delay time has to satisfy both analog time(ns) and clock count(nCK).  
For example, tCMDCKE will not expire until CK has toggled through at least 3 full cycles (3 \*tCK) and 3.75ns has transpired.  
The case which 3nCK is applied to is shown below.

**Figure - tCMDCKE Timing**



**Table - PPR Timing Parameters**

Parameter	Symbol	LPDDR4		Unit	Notes
		Min	Max		
PPR Programming Time	tPGM	1000	-	ms	
PPR Exit Time	tPGM_Exit	15	-	ns	
New Address Setting Time	tPGMPST	50	-	us	

**Table - Temperature Derating for AC timing**

Parameter	Symbol	min max	DDR4	DDR4	DDR4	DDR4	DDR4	DDR4	DDR4	Unit	Note
			533	1066	1600	2133	2667	3200	3733		
DQS Output access time from CK_t/CK_c (derated)	tDQSCKd	max	3600							ps	1
RAS-to-CAS delay (derated)	tRCd	min	tRC + 1.875							ns	1
Activate-to-Activate command period (derated)	tRCd	min	tRC + 3.75							ns	1
Row active time (derated)	tRASd	min	tRAS + 1.875							ns	1
Row precharge time (derated)	tRPd	min	tRP + 1.875							ns	1
Active bank A to Active bank B (derated)	tRRDd	min	tRRD + 1.875							ns	1

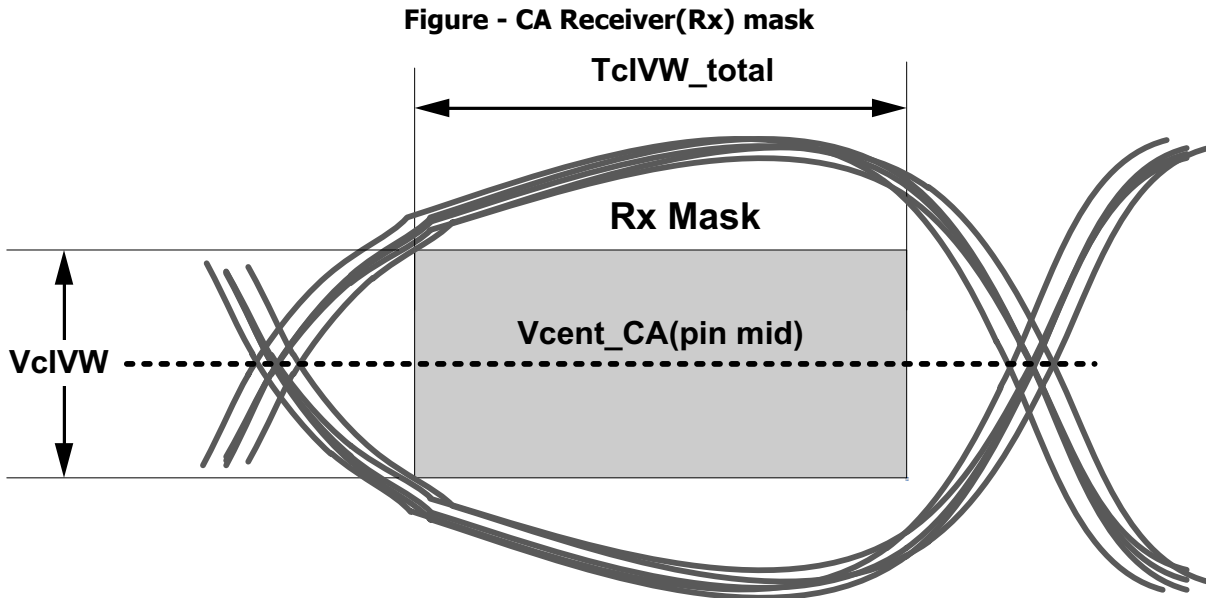
Notes:

1. Timing derating applies for operation at 85°C to 105°C

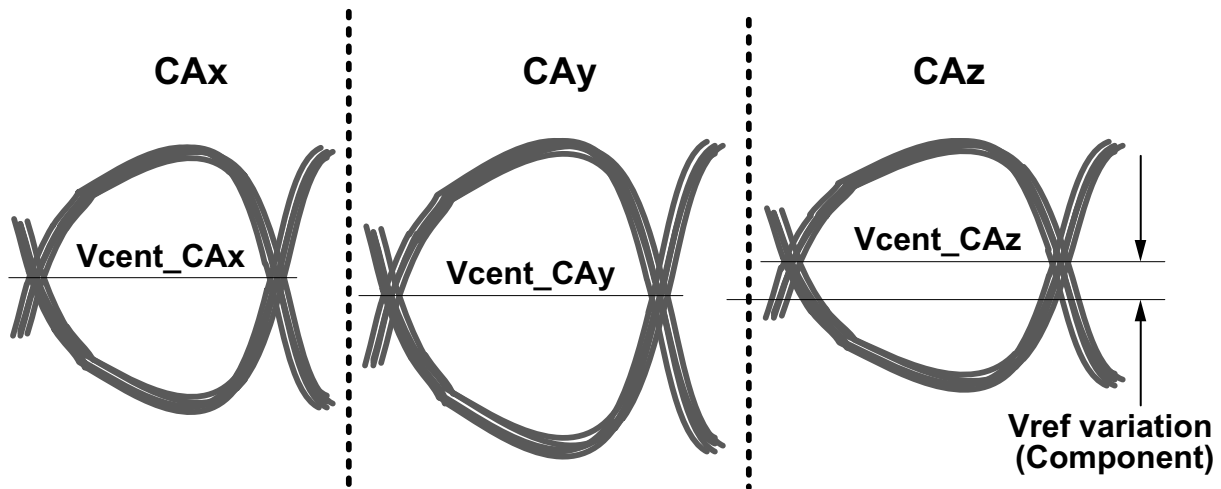
### 9.2. CA Rx voltage and timing

The command and address(CA) including CS input receiver compliance mask for voltage and timing is shown in the figure below. All CA, CS signals apply the same compliance mask and operate in single data rate mode.

The CA input receiver mask for voltage and timing is shown in the figure below is applied across all CA pins. The receiver mask (Rx Mask) defines the area that the input signal must not encroach in order for the DRAM input receiver to be expected to be able to successfully capture a valid input signal; it is not the valid data-eye.



**Figure - Across pin Vref CA voltage variation**

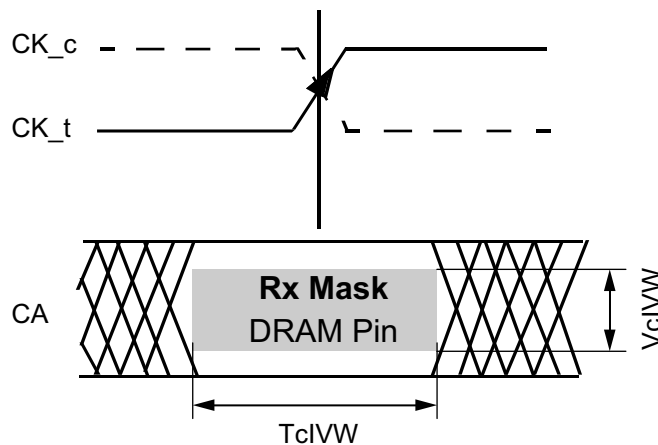


Vcent\_CA(pin avg) is defined as the midpoint between the largest Vcent\_CA voltage level and the smallest Vcent\_CA voltage level across all CA and CS pins for a given DRAM component. Each CA pin Vcent level is defined by the center, i.e. widest opening, of the cumulative data input eye as depicted in the above figure. This clarifies that any DRAM component level variation must be accounted for within the DRAM CA Rx mask. The component level Vref will be set by the system to account for Ron and ODT settings.

**Figure - CA Timing at the DRAM pins**

**CK\_t, CK\_c Data-in at DRAM Pin**

**Minimum CA Eye center aligned**

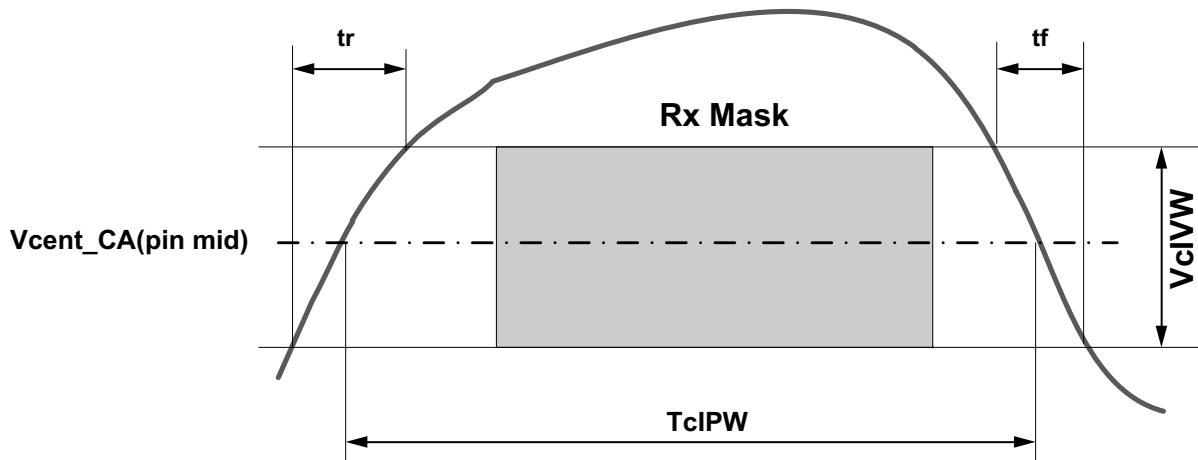


TcIVW for all CA signals is defined as centered on the CK\_t/CK\_c crossing at the DRAM pin.

All of the timing terms in figure 150 are measured from the CK\_t/CK\_c to the center(midpoint) of the TcIVW window taken at the VcIVW\_total voltage levels centered around Vcent\_CA(pin mid).



**Figure - CA TcIPW and SRIN\_cIVW definition (for each input pulse)**



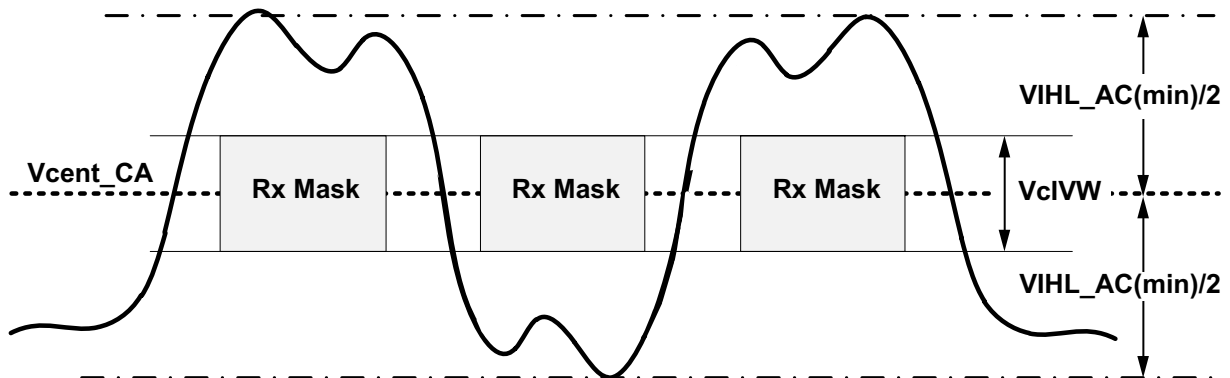
Note

1.  $SRIN\_cIVW = VcIVW\_Total / (tr \text{ or } tf)$ , signal must be monotonic within  $tr$  and  $tf$  range.

Notes:

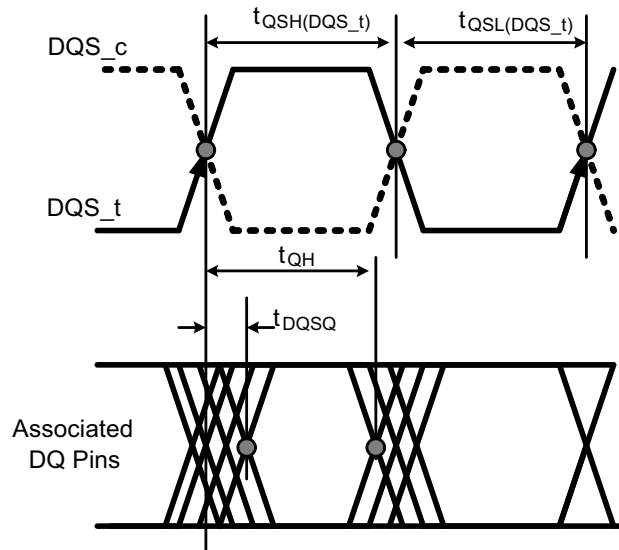
1.  $SRIN\_cIVW = VcIVW / (tr \text{ or } tf)$ , signal must be monotonic within  $tr$  and  $tf$  range.

**Figure - CA VIHIL\_AC definition (for each input pulse)**

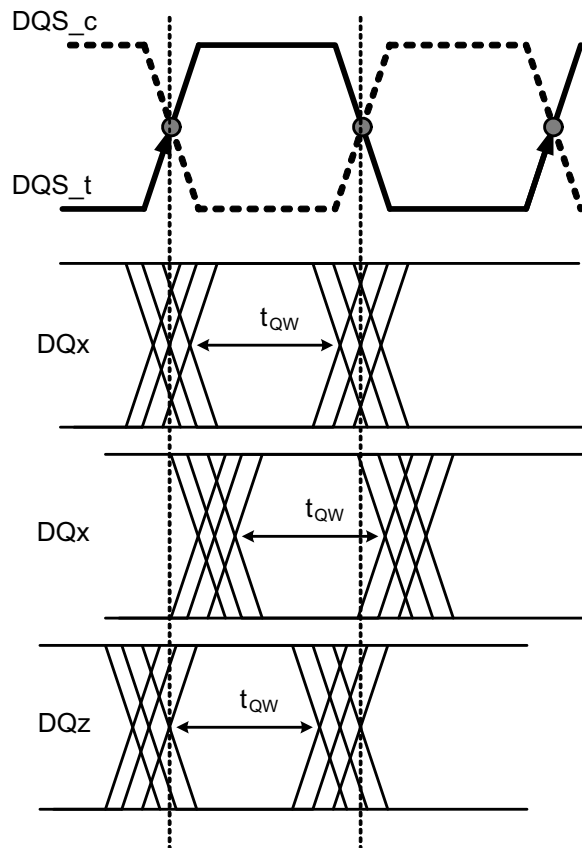


### 9.3. DRAM Data Timing

**Figure - Read data timing definitions  $t_{QH}$  and  $t_{DQSQ}$  across on DQ signals per DQS group**

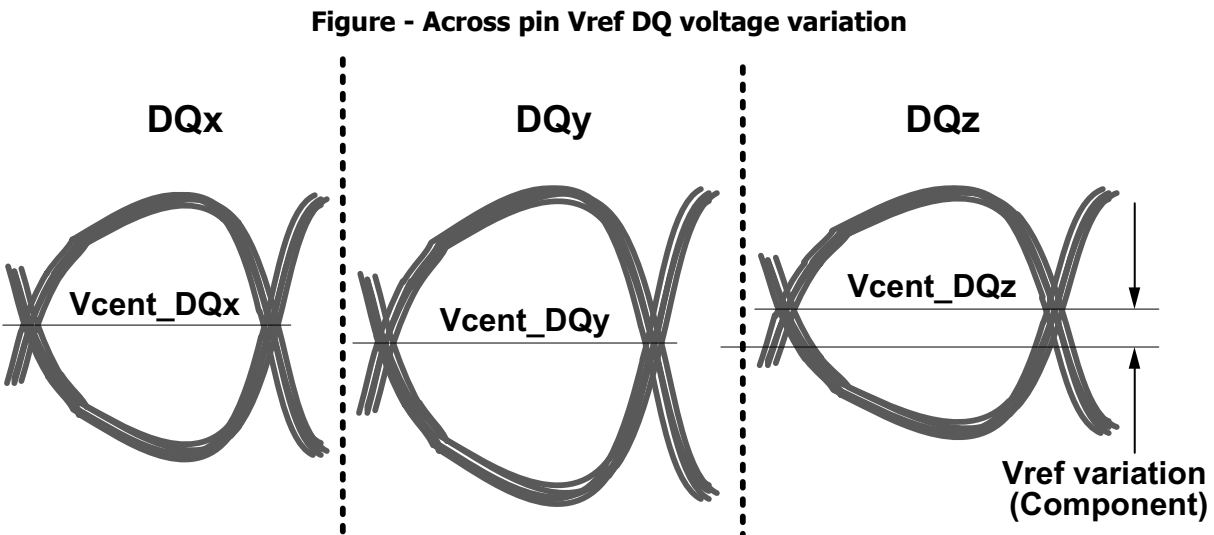
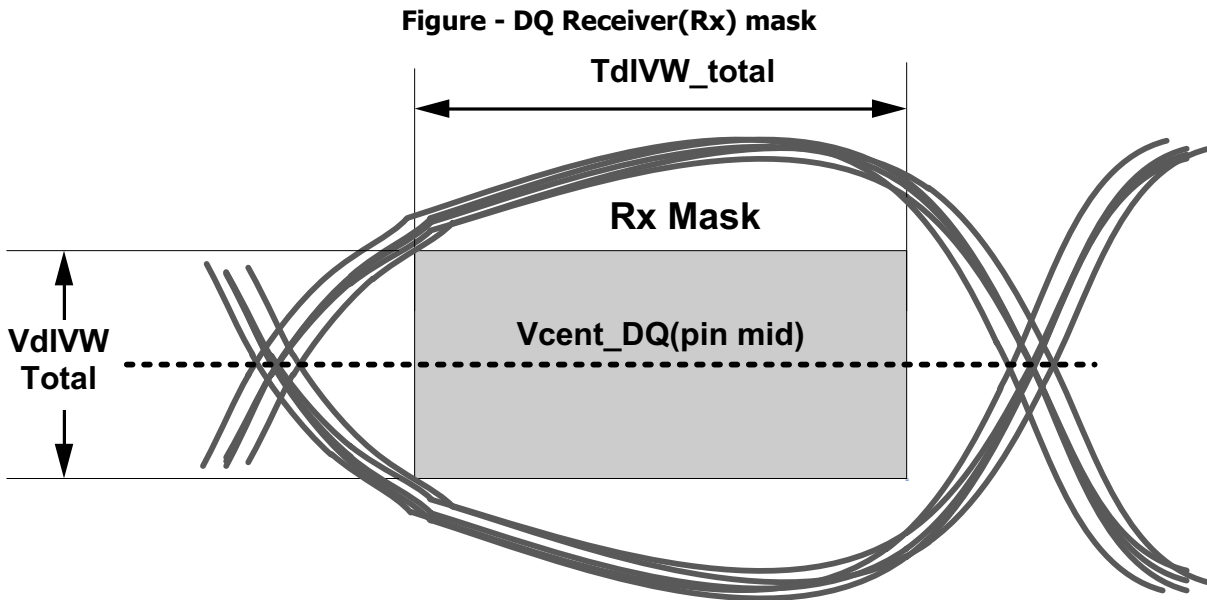


**Figure - Read data timing  $t_{QW}$  valid window defined per DQ signal**



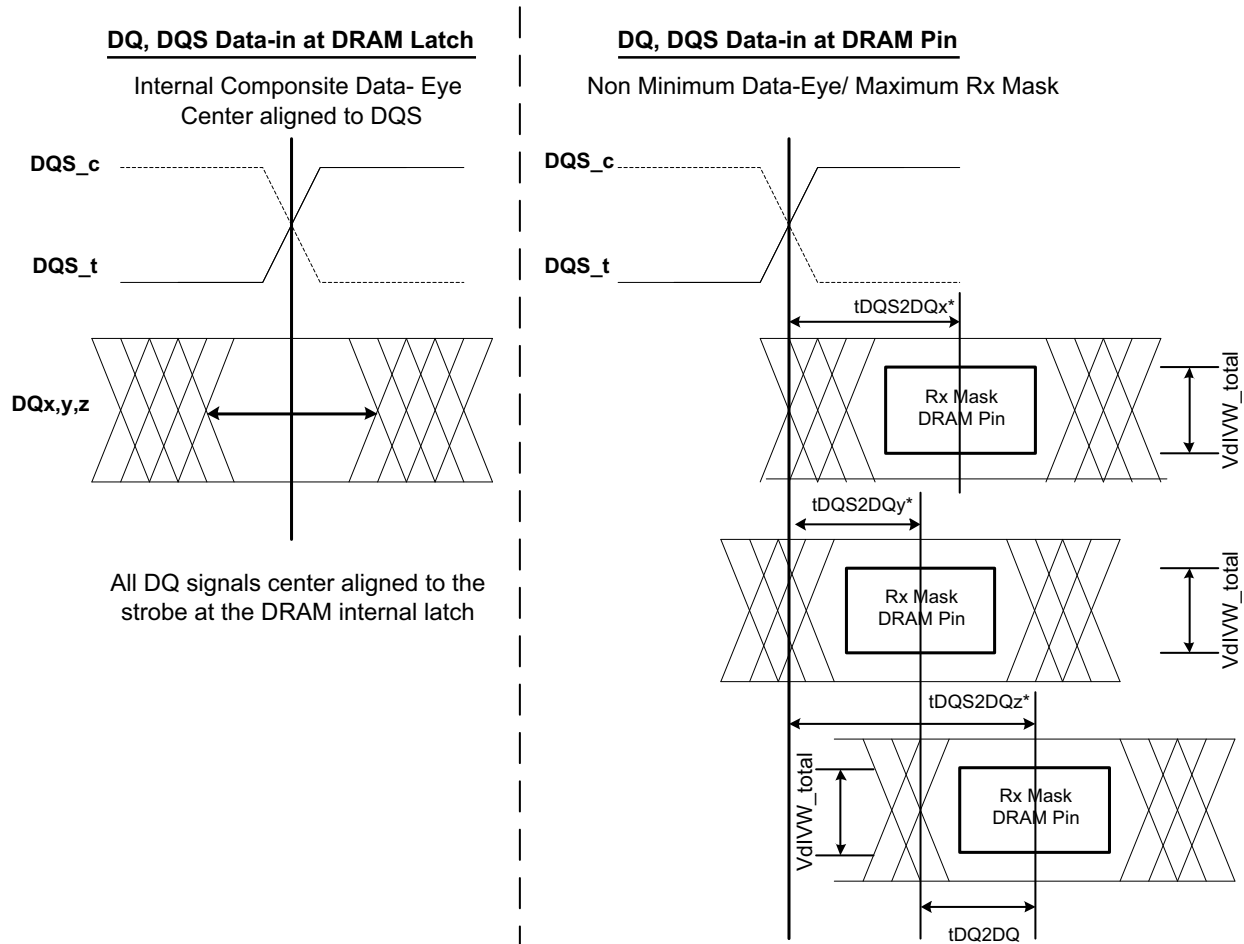
### 9.4. DQ Rx Voltage and Timing Definition

The DQ input receiver mask for voltage and timing is shown in figure below, is applied per pin. The "total" mask ( $V_{dIVW\_total}$ ,  $T_{dIVW\_total}$ ) defines the area the input signal must not encroach in order for the DQ input receiver to successfully capture an input signal with a BER of lower than TBD. The mask is a receiver property and it is not the valid data-eye.



$V_{cent\_DQ}(\text{pin\_mid})$  is defined as the midpoint between the largest  $V_{cent\_DQ}$  voltage level and the smallest  $V_{cent\_DQ}$  voltage level across all DQ pins for a given DRAM component. Each DQ  $V_{cent}$  is defined by the center, i.e. widest opening, of the cumulative data input eye as depicted in the above figure. This clarifies that any DRAM component level variation must be accounted for within the DRAM Rx mask. The component level VREF will be set by the system to account for  $R_{on}$  and ODT settings.

**Figure - DQ to DQS (tDQS2DQ and tDQDQ) Timings at the DRAM pins referenced from the internal latch**

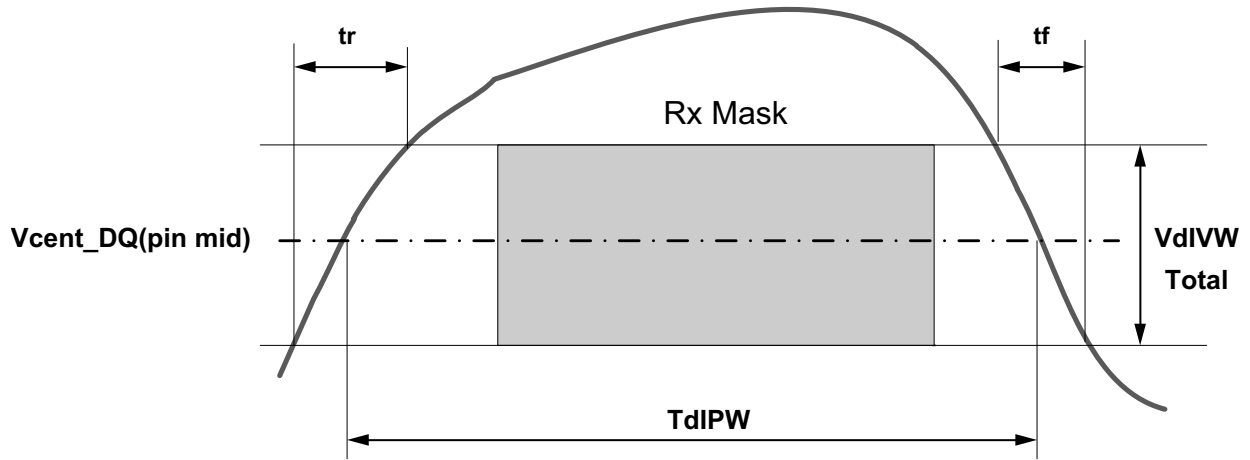


**NOTE:**

1. tDQS2DQ is measured at the center(midpoint) of the TdIVW window.
2. DQz represents the max tDQS2DQ in this example
3. DQy represents the min tDQS2DQ in this example

All of the timing terms in DQ to DQS t are measured from the DQS\_t/DQS\_c to the center(midpoint) of the TdIVW window taken at the VdIVW\_total voltage levels centered around Vcent\_DQ(pin\_mid). In the above figure the timings at the pins are referenced with respect to all DQ signals center aligned to the DRAM internal latch. The data to data offset is defined as the difference between the min and max tDQS2DQ for a given component.

**Figure - DQ TdIPW and SRIN\_dIVW definition (for each input pulse)**



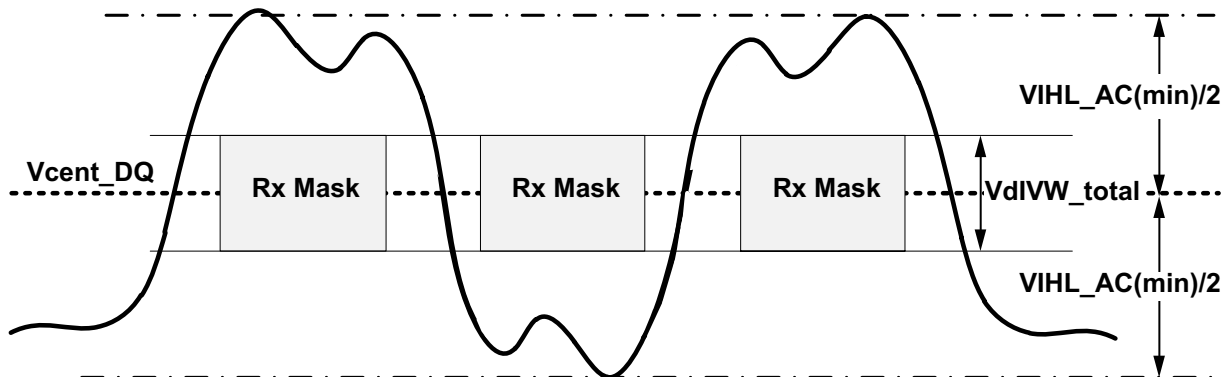
Note

1.  $SRIN\_dIVW = VdIVW\_Total / (tr \text{ or } tf)$ , signal must be monotonic within tr and tf range.

Notes:

1.  $SRIN\_dIVW = VdIVW\_Total / (tr \text{ or } tf)$ , signal must be monotonic within tr and tf range.

**Figure - DQ VIH<sub>L</sub>\_AC definition (for each input pulse)**



## 5. Revision History

### Document History Page

Document Title: S5AA2200IA0 , 4Gb x8, 2Gb x16, 1.8V NAND Flash Memory, LPDDR4x SDRAM				
Document Number: 003-00005				
Rev.	ECN No.	Orig. of Change	Submission Date	Description of Change
**		MNADA	5/8/2020	Initial release