

SkyHigh SLC NAND FLASH MEMORY



INTRODUCTION

SkyHigh's highly reliable SLC NAND products offer a high-density solution optimized for embedded systems. SkyHigh products include differentiated features such as operating temperature support up to 105°C, AEC-Q100 qualification for automotive applications and packages as small as 52mm². All of SkyHigh's SLC NAND products are backed by SkyHigh's world-class customer support and commitment of supply longevity. For applications where security is a priority, SkyHigh offers the SL-2 SecureNAND™ and ML-3 product family which provides enhanced protection features.

FEATURED PRODUCT FAMILIES

ML-1/MS-1	ML-2/MS-2	ML-3	SL-2
Densities : 1Gb to 8Gb	Densities : 1Gb to 16Gb	Densities : 4Gb to 16Gb	Densities : 1Gb to 4Gb
Voltages : 3V and 1.8V options	Voltages : 3V and 1.8V options	Voltages : 3V	Voltages : 3V
Reliability : 100,000 P/E Cycles 10-year Data Retention	Reliability : 100,000 P/E Cycles 10-year Data Retention	Reliability : 60,000 P/E Cycles 10-year Data Retention	Reliability : 100,000 P/E Cycles 10-year Data Retention
ECC : 1-bit ECC	ECC : 4-bit ECC	ECC : 1-bit ECC	ECC : 4-bit ECC
Temperature : -40°C to +85°C -40°C to +105°C	Temperature : -40°C to +85°C -40°C to +105°C	Temperature : -40°C to +85°C -40°C to +105°C	Temperature : -40°C to +85°C -40°C to +105°C
Package : 48-pin TSOP 12x20x1.2mm 63-ball BGA 9x11x1.0mm	Package : 48-pin TSOP 12x20x1.2mm 63-ball BGA 9x11x1.0mm 67-ball BGA 8x6.5x1.0mm	Package : 48-pin TSOP 12x20x1.2mm 63-ball BGA 9x11x1.0mm	Package : 63-ball BGA 9x11x1.0mm
		Security : Enhanced Protection Features	Security : Enhanced Protection Features

KEY APPLICATIONS

Automotive Instrument Clusters and Infotainment Systems | Communication Equipment | Consumer Electronics | Industrial Automation

FUNCTIONAL REPRESENTATION

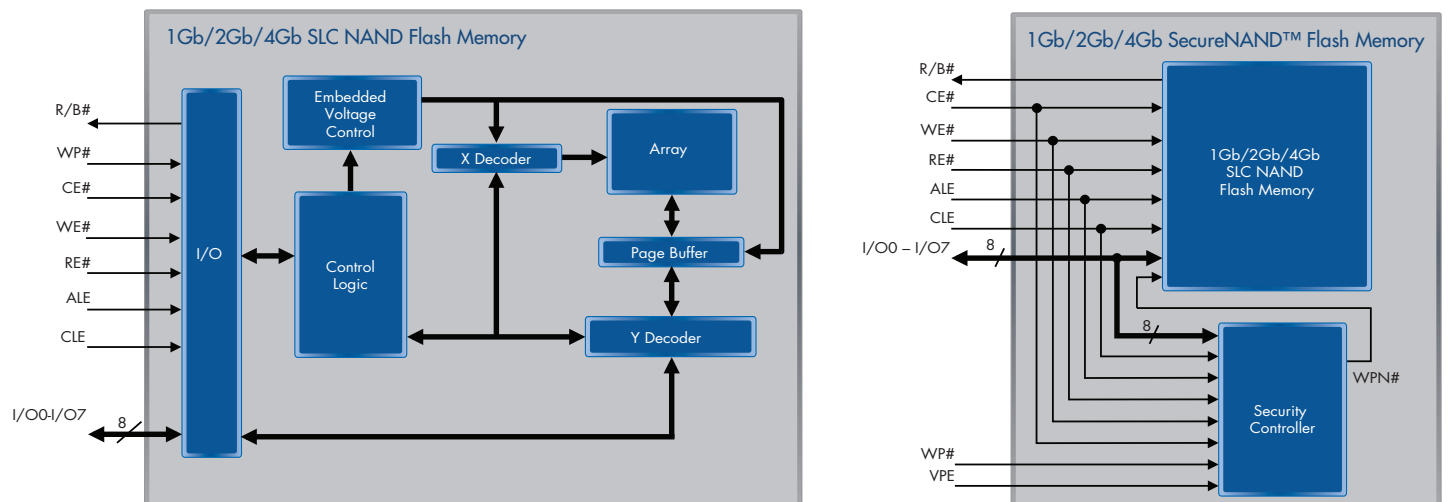

SLC NAND FLASH PORTFOLIO FEATURED PARTS

Family	Voltage	1Gb	2Gb	4Gb	8Gb	16Gb	
ML-1	3.0V	S34ML01G1	S34ML02G1	S34ML04G1	S34ML08G1		
		48-pin TSOP 63-ball BGA					
MS-1	1.8V	S34MS01G1	S34MS02G1	S34MS04G1			
		63-ball BGA	48-pin TSOP 63-ball BGA				
ML-2	3.0V	S34ML01G2	S34ML02G2	S34ML04G2	S34ML08G2	S34ML16G2	
		48-pin TSOP 63-ball BGA 67-ball BGA			48-pin TSOP 63-ball BGA		
MS-2	1.8V	S34MS01G2	S34MS02G2	S34MS04G2	S34MS08G2	S34MS16G2	
		48-pin TSOP 63-ball BGA 67-ball BGA			48-pin TSOP 63-ball BGA	63-ball BGA	
ML-3	3.0V				S34ML04G3	S34ML08G3	S34ML16G3
					48-pin TSOP 63-ball BGA 67-ball BGA		48-pin TSOP
SL-2	3.0V	S34SL01G2	S34SL02G2	S34SL04G2			
		63-ball BGA					

This table is only a summary. To view SkyHigh's entire NAND Flash Memory portfolio, please visit:

<http://www.skyhighmemory.com>